



Designation: C506M – 12a

# Standard Specification for Reinforced Concrete Arch Culvert, Storm Drain, and Sewer Pipe (Metric)<sup>1</sup>

This standard is issued under the fixed designation C506M; the number immediately following the designation indicates the year of original adoption or, in the case of revision, the year of last revision. A number in parentheses indicates the year of last reapproval. A superscript epsilon ( $\epsilon$ ) indicates an editorial change since the last revision or reapproval.

*This standard has been approved for use by agencies of the Department of Defense.*

## 1. Scope

1.1 This specification covers reinforced arch-shaped concrete pipe to be used for the conveyance of sewage, industrial wastes, storm water, and for the construction of culverts.

1.2 This specification is the SI companion to Specification C506.

NOTE 1—This specification is a manufacturing and purchase specification only, and does not include requirements for bedding, backfill, or the relationship between field load condition and the strength classification of pipe. However, experience has shown that the successful performance of this product depends upon the proper selection of the class of pipe, type of bedding and backfill, and care that the installation conforms to the construction specifications. The owner of the reinforced concrete pipe specified herein is cautioned that he must correlate the field requirements with the class of pipe specified and provide inspection at the construction site.

## 2. Referenced Documents

### 2.1 ASTM Standards:<sup>2</sup>

- A36/A36M Specification for Carbon Structural Steel
- A615/A615M Specification for Deformed and Plain Carbon-Steel Bars for Concrete Reinforcement
- A706/A706M Specification for Low-Alloy Steel Deformed and Plain Bars for Concrete Reinforcement
- A1064/A1064M Specification for Steel Wire and Welded Wire Reinforcement, Plain and Deformed, for Concrete
- C33 Specification for Concrete Aggregates
- C150 Specification for Portland Cement
- C260 Specification for Air-Entraining Admixtures for Concrete
- C309 Specification for Liquid Membrane-Forming Compounds for Curing Concrete

<sup>1</sup> This specification is under the jurisdiction of ASTM Committee C13 on Concrete Pipe and is the direct responsibility of Subcommittee C13.02 on Reinforced Sewer and Culvert Pipe.

Current edition approved Sept. 15, 2012. Published October 2012. Originally approved in 1980. Last previous edition approved in 2012 as C506M – 12. DOI: 10.1520/C0506M-12A.

<sup>2</sup> For referenced ASTM standards, visit the ASTM website, www.astm.org, or contact ASTM Customer Service at service@astm.org. For *Annual Book of ASTM Standards* volume information, refer to the standard's Document Summary page on the ASTM website.

C494/C494M Specification for Chemical Admixtures for Concrete

C497M Test Methods for Concrete Pipe, Manhole Sections, or Tile [Metric]

C595 Specification for Blended Hydraulic Cements

C618 Specification for Coal Fly Ash and Raw or Calcined Natural Pozzolan for Use in Concrete

C822 Terminology Relating to Concrete Pipe and Related Products

C989 Specification for Slag Cement for Use in Concrete and Mortars

C1017/C1017M Specification for Chemical Admixtures for Use in Producing Flowing Concrete

C1116 Specification for Fiber-Reinforced Concrete and Shotcrete

## 3. Terminology

3.1 *Definitions*—For definitions of terms relating to concrete pipe, see Terminology C822.

## 4. Classification

4.1 Pipe manufactured according to this specification shall be of three classes identified as Class A-II, A-III, and A-IV. The strength requirements are prescribed in Table 1.

## 5. Basis of Acceptance

5.1 Unless otherwise designated by the owner at the time of, or before placing an order, there are two separate and alternative bases of acceptance. Independent of the method of acceptance, the pipe shall be designed to meet both the 0.01-in. crack and ultimate strength requirements.

5.1.1 *Acceptance on Basis of Plant Load Bearing Tests, Material Tests, and Inspection of Manufactured Pipe for Visual Defects and Imperfections*—Acceptability of the pipe in all diameters and classes produced in accordance with 7.1 or 7.2 shall be determined by the results of the three-edge-bearing tests as defined in 11.3.1; by such material tests as are required in accordance with 6.2, 6.3, 6.5, and 6.6, by an absorption test of the concrete from the wall of the pipe as required in 11.9; and by visual inspection of the finished pipe to determine its conformance with the accepted design and its freedom from defects.

**TABLE 1 Strength Requirements for Reinforced Concrete Pipe<sup>A</sup>**

Approximate Equivalent Round Size, mm	T, mm	Minimum Rise, mm	Minimum Span, mm	Double Line Reinforcement <sup>C</sup>																				
				$f'c^B$ MPa			Continuous Basic Reinforcement = A									Additional Reinforcement = $A_s^D$						Single Line Reinforcement		
				Class			Inner Cage			Outer Cage			"U" (Inner Cage)			"V" (Outer Cage)								
				A-II	A-III	A-IV	A-II	A-III	A-IV	A-II	A-III	A-IV	Dimension, mm	A-II	A-III	A-IV	Dimension, mm	A-II	A-III	A-IV	A-II	A-III	A-IV	
375	57	280	460	27.6	27.6	27.6	...	...	...	...	...	...	...	...	...	...	...	...	...	1.7	2.5	3.6		
450	63	345	560	27.6	27.6	27.6	...	...	...	...	...	...	...	...	...	...	...	...	...	2.3	3.0	5.5		
525	69	395	660	27.6	27.6	27.6	...	...	...	...	...	...	...	...	...	...	...	...	...	2.8	3.6	6.1		
600	75	460	725	27.6	27.6	27.6	...	...	...	...	...	660	...	...	735	...	...	...	...	3.4	4.6	6.8		
750	88	570	920	27.6	27.6	27.6	1.9	2.5	3.8	1.5	1.9	3.0	760	1.9	2.5	3.8	865	1.5	1.9	2.8	3.8	5.1	7.6	
900	100	675	1110	27.6	27.6	27.6	2.3	3.2	4.6	1.9	2.5	3.6	865	2.3	3.2	4.6	990	1.9	2.5	3.4	4.6	6.3	9.3	
1050	113	795	1300	27.6	27.6	27.6	2.8	3.8	5.7	2.1	3.0	4.4	1065	2.8	3.8	5.7	1090	2.1	3.0	4.6	5.5	7.6	11.4	
1200	125	915	1485	27.6	27.6	...	3.2	4.6	...	2.5	3.6	...	1220	3.2	4.6	...	1245	2.5	3.6	...	6.3	9.3	...	
1350	138	1015	1650	27.6	27.6	...	3.8	5.1	...	3.0	4.0	...	1320	3.8	5.1	...	1395	3.0	4.0	...	7.6	10.2	...	
1500	150	1145	1855	27.6	27.6	...	4.4	5.9	...	3.6	4.6	...	1525	4.4	5.9	...	1700	3.6	4.6	...	8.9	11.8	...	
1800	175	1370	2235	27.6	34.5	...	5.5	7.6	...	4.2	5.9	...	1725	5.5	7.6	...	1955	4.2	5.9	...	11.0	15.2	...	
2100	200	1575	2590	27.6	34.5	...	6.8	9.3	...	5.1	7.2	...	...	6.8	9.3	...	...	5.1	7.2	...	13.5	18.6	...	
2250	213	1830	2920	...	...	...	...	...	...	...	...	...	...	...	...	...	...	...	...	...	...	...	...	
2400	225	1960	3100	...	...	...	...	...	...	...	...	...	...	...	...	...	...	...	...	...	...	...	...	
2700	250	2215	3505	...	...	...	...	...	...	...	...	...	...	...	...	...	...	...	...	...	...	...	...	
3000	275	2460	3910	...	...	...	...	...	...	...	...	...	...	...	...	...	...	...	...	...	...	...	...	
3300	250	2705	4285	...	...	...	...	...	...	...	...	...	...	...	...	...	...	...	...	...	...	...	...	

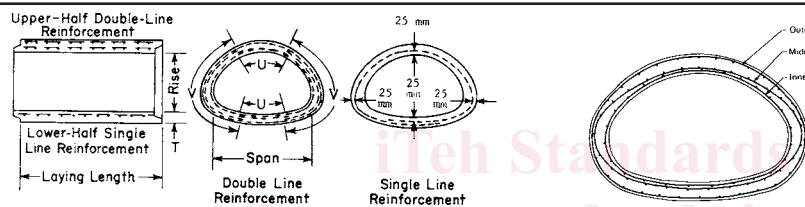

Class	0.3-mm Crack	Ultimate
A-II	50.0	75.0
A-III	65.0	100.0
A-IV	100.0	150.0

Note—Test load in newtons per linear metre equals D-load × inside span in millimetres.

<sup>A</sup> For modified or special designs, see 7.3.

<sup>B</sup>  $f'c$  = minimum compressive strength of concrete in megapascals.

<sup>C</sup> As an alternative to designs requiring double line reinforcement, the reinforcement may be positioned and proportioned so that the total reinforcement of the inner cage plus the middle cage shall not be less than that specified for the inner cage continuous basic reinforcement, and the additional reinforcement "U" and the total reinforcement of the outer cage plus the middle cage shall not be less than that specified for the outer cage continuous basic reinforcement and the additional reinforcement "V."

<sup>D</sup>  $A_s$  = circumferential steel area in square millimetres per longitudinal centimetre of pipe barrel in each continuous basic cage and additional cages in area denoted "U" and "V." Dimensions "U" and "V" are measured on the center line of the culvert wall.

5.1.2 *Acceptance on the Basis of Material Test and Inspection of Manufactured Pipe for Defects and Imperfections*—Acceptability of the pipe in all diameters and classes produced in accordance with 7.1 or 7.2 shall be determined by the results of such material tests as are required in accordance with 6.2, 6.3, 6.5, and 6.6; by crushing tests on concrete cores or cured concrete cylinders; by an absorption test of the concrete from the wall of the pipe for each mix design that is used on an order; and by inspection of the finished pipe, including amount and placement of reinforcement, to determine its conformance with the accepted design and its freedom from defects.

5.1.3 When agreed upon by the owner and the manufacturer, any portion or any combination of the tests itemized in 5.1.1 or 5.1.2 may form the basis of acceptance.

5.2 *Age for Acceptance*—Pipe shall be considered ready for acceptance when they conform to the requirements as indicated by the specified tests.

**6. Materials**

6.1 *Reinforced Concrete*—The reinforced concrete shall consist of cementitious materials, mineral aggregates, and

water, in which steel has been embedded in such a manner that the steel and concrete act together.

6.2 *Cementitious Materials:*

6.2.1 *Cement*—Cement shall conform to the requirements of Specification C150, or shall be portland blast-furnace slag cement, or slag modified portland cement, or portland-pozzolan cement conforming to the requirements of Specification C595, except that the pozzolan constituent in the Type IP portland pozzolan cement shall be fly ash and shall not exceed 25 % by weight.

6.2.2 *Ground Granulated Blast-Furnace Slag (GGBFS)*—GGBFS shall conform to the requirements of Grade 100 or 120 of Specification C989.

6.2.3 *Fly Ash*—Fly ash shall conform to the requirements of Class F or Class C of Specification C618.

6.2.4 *Allowable Combinations of Cementitious Materials*—The combination of cementitious materials used in the concrete shall be one of the following:

- 6.2.4.1 Portland cement only,
- 6.2.4.2 Portland blast furnace slag cement only,
- 6.2.4.3 Slag modified portland cement only,

- 6.2.4.4 Portland pozzolan cement only,
- 6.2.4.5 A combination of portland cement and ground granulated blast-furnace slag,
- 6.2.4.6 A combination of portland cement and fly ash,
- 6.2.4.7 A combination of portland cement, ground granulated blast-furnace slag (not to exceed 25 % of the total cementitious weight) and fly ash (not to exceed 25 % of the total cementitious weight), or
- 6.2.4.8 A combination of portland pozzolan cement and fly ash.

6.3 *Aggregates*—Aggregates shall conform to Specification C33 except that the requirement for gradation shall not apply.

6.4 *Admixtures and Blends*—The following admixtures and blends are allowable:

- 6.4.1 Air-entraining admixture conforming to Specification C260;
- 6.4.2 Chemical admixture conforming to Specification C494/C494M;
- 6.4.3 Chemical admixture for use in producing flowing concrete conforming to Specification C1017/C1017M; and
- 6.4.4 Chemical admixture or blend approved by the owner.

6.5 *Steel Reinforcement*—Reinforcement shall conform to the requirements of Specification A1064/A1064M, or bars

conforming to Specification A36/A36M, Specification A615/A615M Grade 40 or 60, or Specification A706/A706M Grade 60.

6.6 *Synthetic Fibers*—Collated fibrillated virgin polypropylene fibers may be used, at the manufacturer’s option, in concrete pipe as a nonstructural manufacturing material. Only Type III synthetic fibers designed and manufactured specifically for use in concrete and conforming to the requirements of Specification C1116 shall be accepted.

**7. Design**

7.1 *Size and Dimensions*—The standard sizes of arch pipe are listed in Table 1. The internal dimensions for each standard size shall be as defined in Fig. 1, subject to the permissible variations of Section 12.

7.2 *Design Tables*—The wall thickness, compressive strength of concrete, and the area of circumferential reinforcement shall be as prescribed in Table 1, subject to the provisions of 7.3, 11.4, and Section 12.

7.2.1 Footnotes to the tables herein are intended to be amplifications of the tabulated requirements and are to be considered applicable and binding as if they were contained in the body of the specification.

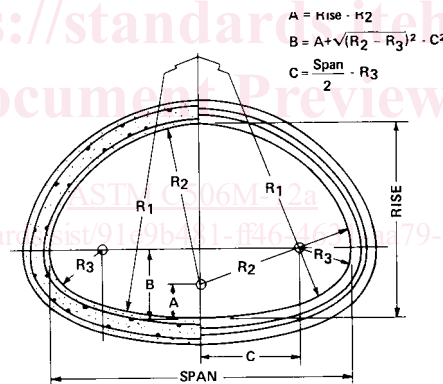

Approximate Equivalent Round Size, mm	Water Area, m <sup>2</sup>	Rise, mm	Span, mm	A, mm	B, mm	C, mm	R <sub>1</sub> , mm	R <sub>2</sub> , mm	R <sub>3</sub> , mm
375	0.10	280	460	10	121	128	580	270	102
450	0.15	345	560	-5	153	145	700	350	135
525	0.20	395	660	20	158	195	900	375	135
600	0.26	460	725	90	153	248	1035	370	115
750	0.41	570	920	95	194	305	1300	475	155
900	0.59	675	1110	105	218	395	1575	570	160
1050	0.82	795	1300	130	258	460	1855	665	190
1200	1.06	915	1485	155	297	522	2135	760	220
1350	1.33	1015	1650	170	330	575	2350	850	250
1500	1.64	1145	1855	190	373	642	2670	955	285
1800	2.38	1370	2235	225	428	798	3200	1145	320
2100	3.21	1575	2590	255	475	940	4130	1320	355
2250	4.13	1830	2920	330	604	970	4650	1500	490
2400	4.80	1960	3100	385	616	1040	5535	1575	510
2700	6.13	2215	3505	435	681	1182	6835	1780	570
3000	7.60	2460	3910	480	740	1345	7655	1980	610
3300	9.21	2705	4285	530	835	1458	8355	2175	685

**FIG. 1 Cross-Sectional Shape of Arch Pipe**