



Designation: ~~C890–06 (Reapproved 2011)~~ C890 – 12

# Standard Practice for Minimum Structural Design Loading for Monolithic or Sectional Precast Concrete Water and Wastewater Structures<sup>1</sup>

This standard is issued under the fixed designation C890; the number immediately following the designation indicates the year of original adoption or, in the case of revision, the year of last revision. A number in parentheses indicates the year of last reapproval. A superscript epsilon ( $\epsilon$ ) indicates an editorial change since the last revision or reapproval.

## 1. Scope

1.1 This practice describes the minimum loads to be applied when designing monolithic or sectional precast concrete water and wastewater structures with the exception of concrete pipe, box culverts, utility structures, and material covered in Specification [C478](#).

1.2 The values stated in inch-pound units are to be regarded as standard. The values given in parentheses are mathematical conversions to SI units that are provided for information only and are not considered standard.

1.3 *This standard does not purport to address all of the safety concerns, if any, associated with its use. It is the responsibility of the user of this standard to establish appropriate safety and health practices and determine the applicability of regulatory limitations prior to use.*

## 2. Referenced Documents

2.1 *ASTM Standards:*<sup>2</sup>

[C478 Specification for Precast Reinforced Concrete Manhole Sections](#)

2.2 *AASHTO Standard:*

[Standard Specifications for Highway Bridges, 16th Edition](#)<sup>3</sup>

2.3 *ACI Standard:*

[ACI 318 Building Code Requirements for Reinforced Concrete](#)<sup>4</sup>

## 3. Terminology

3.1 *Definitions of Terms Specific to This Standard:* [ASTM C890-12](#)

3.1.1 *above ground structures*—all structures with their base at or above ground. [3c2-e64cfa8adf/astm-c890-12](#)

3.1.2 *bearing loads*—the foundation pressure reaction to all other loads acting on the structure.

3.1.3 *below ground structures*—all structures other than those with their base at or above ground.

3.1.4 *dead loads*—the mass of the structure and all permanent loads imposed on the structure.

3.1.5 *equipment loads*—loads induced into the structure by equipment installed on mounting devices cast into the structure.

3.1.6 *hydrostatic loads*—all pressures due to the weight of water or other liquids.

3.1.7 *lateral earth loads*—the lateral pressure due to the effective weight of adjacent earth backfill.

3.1.8 *lifting loads*—the forces induced into the structure during handling at the precast plant and the construction site.

3.1.9 *surcharge loads*—the lateral pressure due to vertical loads superimposed on the adjacent earth backfill.

3.1.10 *traffic loads*—all loads superimposed on the structure or adjacent earth backfill due to vehicles or pedestrians.

<sup>1</sup> This practice is under the jurisdiction of ASTM Committee [C27](#) on Precast Concrete Products and is the direct responsibility of Subcommittee [C27.30](#) on Water and Wastewater Containers.

Current edition approved ~~May 1, 2011~~ Sept. 15, 2012. Published ~~June 2011~~ October 2012. Originally approved in 1978. Last previous edition approved in ~~2006~~ 2011 as [C890–06–06 \(2011\)](#). DOI: ~~10.1520/C0890-06RH~~ 10.1520/C0890-12.

<sup>2</sup> For referenced ASTM standards, visit the ASTM website, [www.astm.org](#), or contact ASTM Customer Service at [service@astm.org](#). For *Annual Book of ASTM Standards* volume information, refer to the standard's Document Summary page on the ASTM website.

<sup>3</sup> Available from American Association of State Highway and Transportation Officials (AASHTO), 444 N. Capitol St., NW, Suite 249, Washington, DC 20001, [http://www.transportation.org](#).

<sup>4</sup> Available from American Concrete Institute (ACI), P.O. Box 9094, Farmington Hills, MI 48333-9094, [http://www.concrete.org](#).

3.1.11 *water and wastewater structures*—solar heating reservoirs, septic tanks, cisterns, holding tanks, leaching tanks, extended aeration tanks, wet wells, pumping stations, grease traps, distribution boxes, oil-water separators, treatment plants, manure pits, catch basins, drop inlets, and similar structures.

#### 4. Significance and Use

4.1 This practice is intended to standardize the minimum loads to be used to structurally design a precast product.

4.2 The user is cautioned that he must properly correlate the anticipated field conditions and requirements with the design loads. Field conditions may dictate loads greater than minimum.

#### 5. Design Loads

##### 5.1 Dead Loads:

5.1.1 Permanent vertical loads typically include the weight of the road bed, walkways, earth backfill, and access opening covers.

5.1.2 Recommended unit weights of materials for design are shown in [Table 1](#).

##### 5.2 Traffic Loads:

5.2.1 The vehicle and pedestrian loadings are shown in [Table 2](#).

5.2.2 The arrangement and spacing of vehicle wheels are shown in [Fig. 1](#) and [Fig. 2](#).

##### 5.2.3 Distribution of Wheel Loads through Earth Fills:

5.2.3.1 For structures where vehicle wheels contact the top surface of the structure, the vehicle wheel loads will be distributed over an area as shown in [Fig. 3](#). The loaded area will be:

$$A = W \times L \quad (1)$$

where:

$A$  = wheel load area, ft<sup>2</sup> (m<sup>2</sup>),

$W$  = wheel width, ft (m), and

$L$  = wheel length, ft (m).

5.2.3.2 For below ground structures where backfill separates the vehicle wheels and the top surface of the structure, the vehicle wheel loads will be distributed as a truncated pyramid as shown in [Fig. 4](#).

The loaded area will be:

$$A = (W + 1.75 H) \times (L + 1.75 H) \quad (2)$$

where:

$A$  = wheel load area, ft<sup>2</sup> (m<sup>2</sup>),

$W$  = wheel width, ft (m),

$L$  = wheel length, ft (m), and

$H$  = height of backfill between wheels and structure, ft (m).

5.2.3.3 When several distributed wheel load areas overlap, the total wheel load will be uniformly distributed over a composite area defined by the outside limits of the individual areas. Such a wheel load distribution is shown in [Fig. 5](#).

5.2.3.4 When the dimensions of the distributed load area or the composite distributed load area exceed the top surface area of the structure, only that portion of the distributed load within the top surface area will be considered in the design.

5.2.4 The effects of impact will increase the live wheel loads designated as A-16, A-12, and A-8 as shown in [Table 3](#).

**TABLE 1 Unit Weights of Materials**

Material	Weight, lbf/ft <sup>3</sup> (N/m <sup>3</sup> )
Concrete (plain or reinforced)	150 (23 600)
Lightweight Concrete (reinforced)	100 to 130 (15 700 to 20 400)
Cast Iron	450 (70 700)
Steel	490 (77 000)
Aluminum	175 (27 500)
Earth Fill	100 to 150 (15 700 to 23 600)
Macadam	140 (22 000)

TABLE 2 Vehicle and Pedestrian Load Designations

Designation	Load, max	Uses
A-16 (HS20-44) <sup>A</sup>	16 000 lbf (71 200 N) per wheel	heavy traffic
A-12 (HS15-44) <sup>A</sup>	12 000 lbf (53 400 N) per wheel	medium traffic
A-8 (H10-44) <sup>A</sup>	8 000 lbf (35 600 N) per wheel	light traffic
A-03	300 lbf/ft <sup>2</sup> (14 400 Pa)	walkways

<sup>A</sup> The designations in parentheses are corresponding ASSHTO designations.

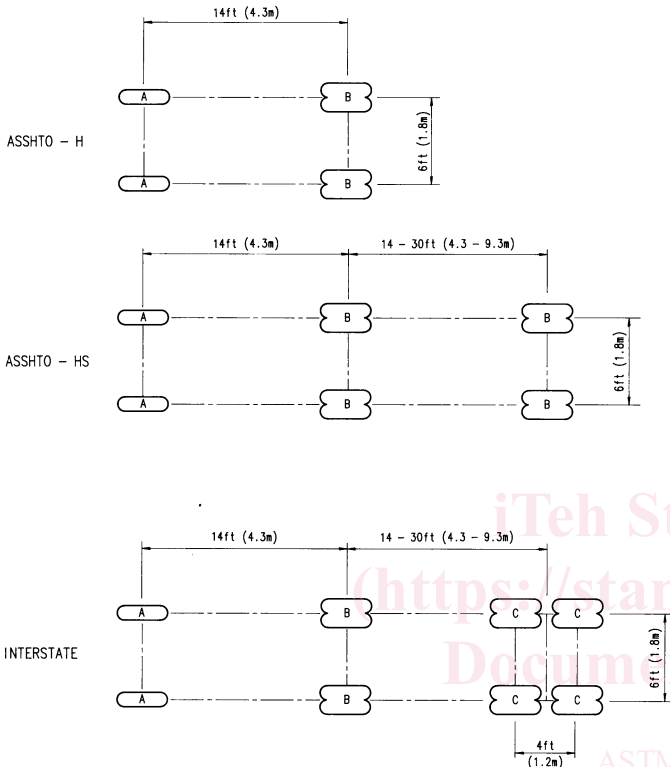

FIG. 1 Single Vehicle Traffic Loads and Spacing

Designation	Load at A		Load at B		Load at C	
	lbf	N	lbf	N	lbf	N
A-16 (HS20-44) <sup>A</sup>	4 000	17 800	16 000	71 200	12 000	53 400
A-12 (HS15-44) <sup>A</sup>	3 000	13 300	12 000	53 400	8 000	35 600
A-8 (H10-44) <sup>A</sup>	2 000	8 900	8 000	35 600	6 000	26 700

<sup>A</sup> The designations in parentheses are corresponding ASSHTO designations.

AASHTO & INTERSTATE

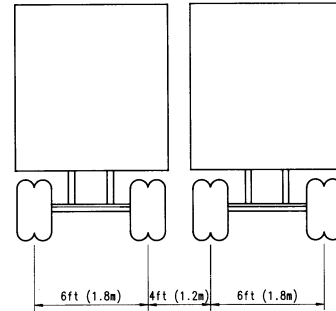

FIG. 2 Multiple Vehicle Spacing

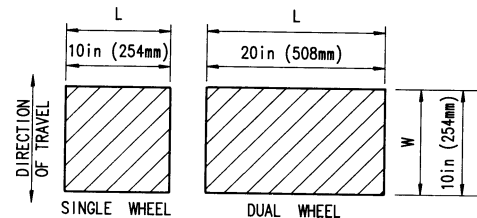

FIG. 3 Wheel Load Area

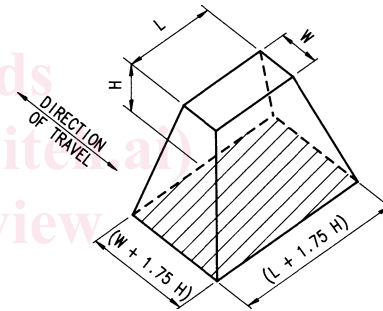

FIG. 4 Distributed Load Area

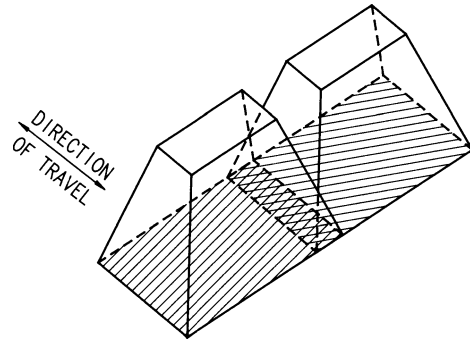

FIG. 5 Composite Distributed Load Area