



# Standard Specification for Doors, Furniture, Marine<sup>1</sup>

This standard is issued under the fixed designation F782; the number immediately following the designation indicates the year of original adoption or, in the case of revision, the year of last revision. A number in parentheses indicates the year of last reapproval. A superscript epsilon ( $\epsilon$ ) indicates an editorial change since the last revision or reapproval.

*This standard has been approved for use by agencies of the U.S. Department of Defense.*

## 1. Scope

1.1 This specification covers the construction of furniture doors for use where invoked by other marine furniture specifications.

1.2 This specification applies to all furniture doors for marine furniture, in items requiring hinged doors.

1.3 Values stated in inch-pound units are to be regarded as the standard. The metric equivalents, given in parentheses, are for information only.

## 2. Referenced Documents

2.1 *ASTM Standards*:<sup>2</sup>

[A240/A240M](#) Specification for Chromium and Chromium-Nickel Stainless Steel Plate, Sheet, and Strip for Pressure Vessels and for General Applications

[A1008/A1008M](#) Specification for Steel, Sheet, Cold-Rolled, Carbon, Structural, High-Strength Low-Alloy, High-Strength Low-Alloy with Improved Formability, Solution Hardened, and Bake Hardenable

[A582/A582M](#) Specification for Free-Machining Stainless Steel Bars

[B209](#) Specification for Aluminum and Aluminum-Alloy Sheet and Plate

[B221](#) Specification for Aluminum and Aluminum-Alloy Extruded Bars, Rods, Wire, Profiles, and Tubes

[C1036](#) Specification for Flat Glass

[D907](#) Terminology of Adhesives

[F2119](#) Test Method for Evaluation of MR Image Artifacts from Passive Implants

<sup>1</sup> This specification is under the jurisdiction of ASTM Committee F25 on Ships and Marine Technology and is the direct responsibility of Subcommittee F25.03 on Outfitting and Deck Machinery.

Current edition approved June 1, 2012. Published October 2012. Originally approved in 1982. Last previous edition approved in 2007 as F782 - 01 (2007). DOI: 10.1520/F0782-01R12.

<sup>2</sup> For referenced ASTM standards, visit the ASTM website, www.astm.org, or contact ASTM Customer Service at service@astm.org. For *Annual Book of ASTM Standards* volume information, refer to the standard's Document Summary page on the ASTM website.

2.2 *American Institute of Steel Construction Manual*:<sup>3</sup>

[AISC Wire and Sheet Metal Gages—Equivalent Thickness in Decimals of an Inch, U.S. Standard Gage \(USSG\) for Uncoated Hot and Cold-Rolled Sheets](#)

2.3 *Federal Specifications*:<sup>4</sup>

[DD-G-1403](#) Glass, Plate (Float), Sheet Figured, and Spandrel (Heat Strengthened and Fully Tempered)

[LP-391](#) Plastic Sheets, Rods and Tubing, Rigid Cast, Methacrylate (Multiapplication)

[QQ-C-320](#) Chromium Plating (Electrodeposited)

[QQ-Z-325](#) Zinc Coating, Electrodeposited

2.4 *American National Standard Institute Standards*:<sup>5</sup>

[ANSI Z97.1-1975](#) Safety Performance Specifications and Methods of Test for Safety Glazing Material Used in Buildings

## 3. Terminology

3.1 *Definitions of Terms Specific to This Standard*:

3.1.1 *flush doors*—metal doors with a smooth surface on the exterior face.

3.1.2 *hinged door*—door equipped with hinges that permit it to swing about the vertical hinge axis, either right hand or left hand.

3.1.2.1 *right-hand door*—door with hinges on the right side when viewed from the exterior of the furniture item containing the door.

3.1.2.2 *left-hand door*—door with hinges on the left side when viewed from the exterior of the furniture item containing the door.

3.1.3 *panel doors*—doors with metal stiles and rails that support a panel insert of transparent safety glazing or expanded aluminum.

<sup>3</sup> Available from the American Institute of Steel Construction, 400 N. Michigan Ave., Chicago, IL 60611.

<sup>4</sup> Available from Standardization Documents Order Desk, Bldg. 4 Section D, 700 Robbins Ave., Philadelphia, PA 19111-5094, Attn: NPODS.

<sup>5</sup> Available from American National Standards Institute (ANSI), 25 W. 43rd St., 4th Floor, New York, NY 10036, <http://www.ansi.org>.

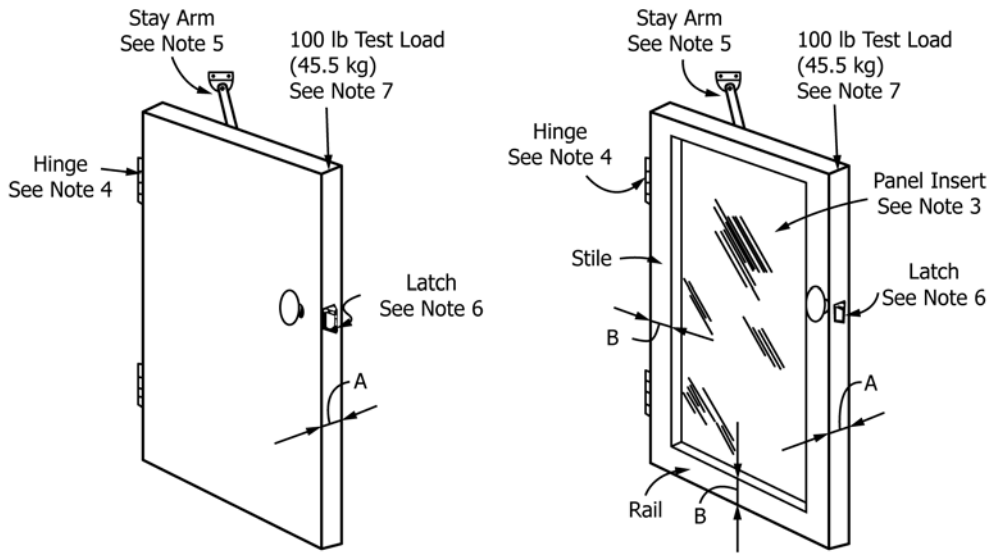

Table of Dimensions

Designation	Dimensions	
	in.	mm
Door thickness	A	1 max 25.4 max
Width of stile or height of rail	B	3 max 76.2 max

NOTE 1—Panels of Type I (flush) doors shall be cold-rolled sheet steel, commercial quality, furniture grade in accordance with Specification A1008/A1008M, 18 USSG (0.0478 in. or 1.21 mm). Stiffeners shall be applied to front and back as required to prevent buckling or oil-canning.

NOTE 2—At the option of the furniture manufacturer the stiles and rails for Type II (panel) door, may be either 18 USSG (0.0478 in. or 1.21 mm) cold-rolled steel, commercial quality, furniture grade in accordance with Specification A1008/A1008M or Type 6063-T6 extruded aluminum in accordance with Specification B221 or 0.064-in. (1.63-mm) thick Type 5052-H32 aluminum alloy sheet in accordance with Specification B209.

NOTE 3—Aluminum Panel inserts for Type II (panel) doors shall be Type 3003-H14 anodized aluminum, 0.081 in. (2.06 mm) thick before expanding and of the Festoon or other approved pattern. Material shall be in accordance with Specification B209 and the anodizing shall be done after metal is expanded. Alternative safety glazing can be furnished if specified in ordering documents. See 6.11.2.1 for description of these alternatives.

NOTE 4—Butt hinges are shown in Fig. 1 and shall be furnished in accordance with 6.8. Type 300 stainless steel pivot or hinges of adequate strength may be used in place of butt hinges.

NOTE 5—Stay arms shall be provided and shall both prevent door from opening more than 90° and be capable of retaining door in 90° open position.

NOTE 6—Doors shall be equipped with latches. See 6.7.1 and 6.7.2 for description of alternative latches.

NOTE 7—Doors shall be capable of resisting vertical load applied at latch edge. See 7.1 for detail of test.

NOTE 8—Doors shall be comply with requirements of tilt test. See 7.2 for details of test.

FIG. 1 Furniture Doors

3.1.3.1 *stiles*—the vertical members in the frame of a panel door that support the central panel.

3.1.3.2 *rails*—the horizontal members in the frame of a panel door that support the central panel.

4. Classification

4.1 Doors shall be of the following types as required by the specifications for the item of furniture in which they are installed and as indicated in ordering documents. See Fig. 1 for details.

- 4.1.1 *Type I*—Flush hinged door.
- 4.1.2 *Type II*—Panel hinged door.

5. Ordering Information

5.1 Doors are included as part of the orders for items of furniture requiring doors. To describe adequately the door or doors required, these orders shall include, as necessary, the following information:

- 5.1.1 Type.

5.1.2 Size, see Section 8.

5.1.3 Paint:

5.1.3.1 *Color*—Per the purchaser’s requirements.

5.1.3.2 Manufacturer’s standard baked enamel will be furnished unless otherwise required and indicated by the purchaser.

5.1.4 For single-hinged doors, indicate hand if not obvious or if a specific hand is required.

5.1.5 Material for Type II (panel) doors may be either steel or aluminum. Material selected shall be the option of the furniture purchaser.

6. Materials and Manufacture

6.1 For typical design, see Fig. 1.

6.2 Sheet metal shall be cold-rolled steel, commercial quality, furniture grade in accordance with Specification A1008/A1008M.