



Designation: **D6392—08 D6392 – 12**

Standard Test Method for Determining the Integrity of Nonreinforced Geomembrane Seams Produced Using Thermo-Fusion Methods¹

This standard is issued under the fixed designation D6392; the number immediately following the designation indicates the year of original adoption or, in the case of revision, the year of last revision. A number in parentheses indicates the year of last reapproval. A superscript epsilon (ϵ) indicates an editorial change since the last revision or reapproval.

1. Scope

1.1 This test method describes destructive quality control and quality assurance tests used to determine the integrity of geomembrane seams produced by thermo-fusion methods. This test method presents the procedures used for determining the quality of nonbituminous bonded seams subjected to both peel and shear tests. These test procedures are intended for nonreinforced geomembranes only.

1.2 The types of thermal field seaming techniques used to construct geomembrane seams include the following.

1.2.1 *Hot Air*—This technique introduces high-temperature air or gas between two geomembrane surfaces to facilitate melting. Pressure is applied to the top or bottom geomembrane, forcing together the two surfaces to form a continuous bond.

1.2.2 *Hot Wedge (or Knife)*—This technique melts the two geomembrane surfaces to be seamed by running a hot metal wedge between them. Pressure is applied to the top or bottom geomembrane, or both, to form a continuous bond. Some seams of this kind are made with dual bond tracks separated by a nonbonded gap. These seams are sometimes referred to as dual hot wedge seams or double-track seams.

1.2.3 *Extrusion*—This technique encompasses extruding molten resin between two geomembranes or at the edge of two overlapped geomembranes to effect a continuous bond.

1.3 The types of materials covered by this test method include the following.

1.3.1 *Very Low Density Polyethylene (VLDPE)*.

1.3.2 *Linear Low Density Polyethylene (LLDPE)*.

1.3.3 *Very Flexible Polyethylene (VFPE)*.

1.3.4 *Linear Medium Density Polyethylene (LMDPE)*.

1.3.5 *High Density Polyethylene (HDPE)*.

1.3.6 *Polyvinyl Chloride (PVC)*.

1.3.7 *Flexible Polypropylene (fPP)*.

NOTE 1—The polyethylene identifiers presented in 1.3.1-1.3.5 describe the types of materials typically tested using this test method. These are industry accepted trade descriptions and are not technical material classifications based upon material density.

1.4 *This standard does not purport to address all of the safety concerns, if any, associated with its use. It is the responsibility of the user of this standard to establish appropriate safety and health practices and determine the applicability of regulatory limitations prior to use.*

2. Referenced Documents

2.1 *ASTM Standards*:²

[D638 Test Method for Tensile Properties of Plastics](#)

[D4439 Terminology for Geosynthetics](#)

[D5199 Test Method for Measuring the Nominal Thickness of Geosynthetics](#)

[D5994 Test Method for Measuring Core Thickness of Textured Geomembranes](#)

¹ This test method is under the jurisdiction of ASTM Committee D35 on Geosynthetics and is the direct responsibility of Subcommittee D35.10 on Geomembranes. Current edition approved July 1, 2008; July 1, 2012. Published July 2008; September 2012. Originally approved in 1999. Last previous edition approved in 2006 as [D6392-99\(2006\)](#); [D6392-08](#). DOI: [10.1520/D6392-08](#); [10.1520/D6392-12](#).

² For referenced ASTM standards, visit the ASTM website, [www.astm.org](#), or contact ASTM Customer Service at [service@astm.org](#). For *Annual Book of ASTM Standards* volume information, refer to the standard's Document Summary page on the ASTM website.

2.2 EPA Standards:

EPA/600/2-88/052 Lining of Waste Containment and Other Containment Facilities; Appendix N, Locus of break codes for various types of FML seams³

3. Terminology

3.1 Definitions of Terms Specific to This Standard:

3.1.1 *geomembrane, n*—essentially impermeable geosynthetic composed of one or more synthetic sheets.

3.1.2 *quality assurance, n*—all planned and systematic actions necessary to provide adequate confidence that an item or a facility will perform satisfactorily in service.

3.1.3 *quality control, n*—the operational techniques and the activities, which sustain a quality of material, product, system, or service that will satisfy given needs; also the use of such techniques and activities.

4. Significance and Use

4.1 The use of geomembranes as barrier materials to restrict liquid migration from one location to another in soil and rock has created a need for a standard test method to evaluate the quality of geomembrane seams produced by thermo-fusion methods. In the case of geomembranes, it has become evident that geomembrane seams can exhibit separation in the field under certain conditions. Although this is an index type test method used for quality assurance and quality control purposes, it is also intended to provide the quality assurance engineer with sufficient seam peel and shear data to evaluate seam quality. Recording and reporting data, such as separation that occurs during the peel test and elongation during the shear test, will allow the quality assurance engineer to take measures necessary to ensure the repair of inferior seams during facility construction, and therefore, minimize the potential for seam separation in service.

5. Apparatus

5.1 Tensile instrumentation shall meet the requirements outlined in Test Method D638.

5.2 *Grip Faces*—Grip faces shall be 25 mm (1 in.) wide and a minimum of 25 mm (1 in.) in length. Smooth rubber, fine serrated or coarse serrated grip faces have all been found to be suitable for testing geomembrane seams.

6. Sample and Specimen Preparation

6.1 *Seam Samples*—Cut a portion of the fabricated seam sample from the installed liner in accordance with the project specifications. It is recommended that the cutout sample be 0.3 m (1 ft) wide and 0.45 m (1.5 ft) in length with the seam centered in the middle.

6.2 *Specimen Preparation*—Ten specimens shall be cut from the sample submittal. The specimens shall be die cut using a 25 mm (nominal 1 in.) wide by a minimum of 150 mm (nominal 6 in.) long die. Specimens that will be subjected to peel and shear tests shall be selected alternately from the sample and labeled as shown in Fig. 1. Specimens shall be cut such that the seam is

³ Available from the Superintendent of Documents, US Government Printing Office, Washington, DC 20402.

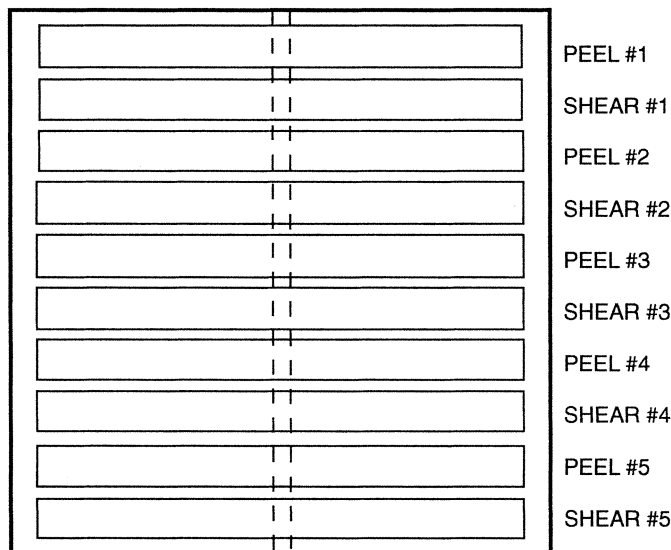

FIG. 1 Seam Sample

perpendicular to the longer dimension of the strip specimen.

6.3 *Conditioning*—Samples should be conditioned for 40 h in a standard laboratory environment that conforms to the requirements for testing geosynthetics as stated in Terminology D4439. Long sample conditioning times typically are not possible for most applications that require seam testing. Prior to testing, samples should be conditioned for a minimum of 1 h at $23 \pm 2^\circ\text{C}$ and a relative humidity between 50 and 70 %.

7. Destructive Test Methods

7.1 *Peel Testing*—Subject five specimens to the 90° “T-Peel” test (see Fig. 2). If the tested sample is a dual hot wedge seam, five specimens must be examined for each external track of the seam. Maintaining the specimen in a horizontal position throughout the test is not required. Fully grip the test specimen across the width of the specimen. Grip the peel specimen by securing grips 25 mm (1 in.) on each side of the start of the seam bond, a constant machine cross head speed of 50 mm (2 in.)/min for HDPE, LMDPE, and PVC, 500 mm (20 in.)/min for LLDPE, VLDPE, VFPE, and fPP. The test is complete when the specimen ruptures.

7.2 *Shear Testing*—Subject five specimens to the shear test (see Fig. 2). Fully support the test specimen within the grips across the width of the specimen. Secure the grips 25 mm (1 in.) on each side of the start of the seam bond, a constant machine cross head speed of 50 mm (2 in.)/min for LMDPE and HDPE, 500 mm (20 in.)/min for fPP, LLDPE, VFPE, VLDPE, and PVC. The test is complete for HDPE and LMDPE once the specimen has elongated 50 %. PVC, fPP, LLDPE, VFPE and VLDPE geomembranes should be tested to rupture.

NOTE 2—Both peel and shear tests for fPP, LLDPE, VLDPE, and PVC geomembranes have been tested routinely at both 2 and 20 in./min. When conducting seam peel or shear testing for quality control, or quality assurance purposes, or both, it may be necessary to select the manufacturer’s recommended testing speed. In the absence of explicit testing speed requirements, follow those recommended in 7.1 and 7.2.

8. Calculations and Observations

8.1 *Estimate of Seam Peel Separation*—Visually estimate the seam separation demonstrated prior to rupture for peel specimens. The estimate shall be based upon the proportion of the area of the separated bond, to the area of original bonding to the nearest 5%. However, if at any point across the width of the peel specimen, seam separation continues to the other side of the bonded area, the estimate of seam peel separation shall be 100%–100% regardless of the proportion of the area of the separated bond to the area of the original bonding.

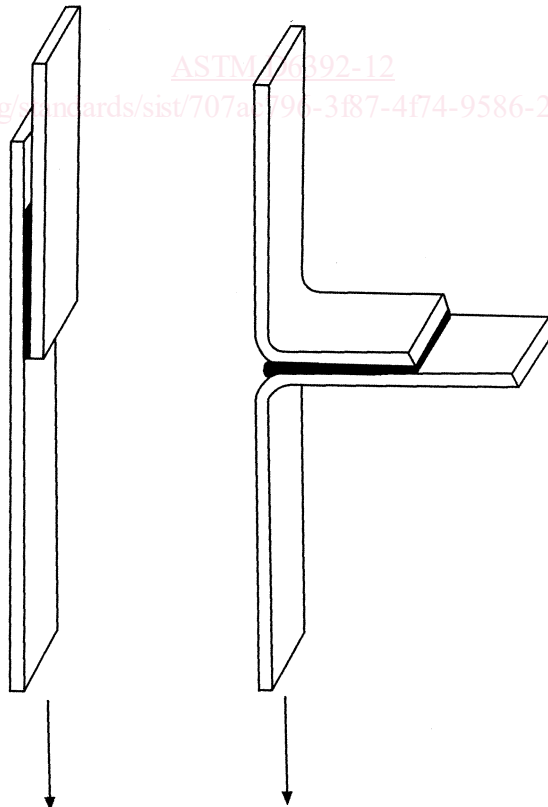

FIG. 2 Shear and T-Peel Specimens