



Designation: D6766 – 12

# Standard Test Method for Evaluation of Hydraulic Properties of Geosynthetic Clay Liners Permeated with Potentially Incompatible Aqueous Solutions<sup>1</sup>

This standard is issued under the fixed designation D6766; the number immediately following the designation indicates the year of original adoption or, in the case of revision, the year of last revision. A number in parentheses indicates the year of last reapproval. A superscript epsilon ( $\epsilon$ ) indicates an editorial change since the last revision or reapproval.

## 1. Scope

1.1 This test method covers laboratory measurement of both flux and hydraulic conductivity (also referred to as *coefficient of permeability*) of geosynthetic clay liner (GCL) specimens permeated with chemical solutions and leachates utilizing a flexible wall permeameter. For test measurement of index hydraulic properties of geosynthetic clay liners, refer to Test Method [D5887](#).

1.2 This test method may be utilized with GCL specimens that have a hydraulic conductivity less than or equal to  $1 \times 10^{-5}$  m/s ( $1 \times 10^{-3}$  cm/s).

1.3 This test method is applicable to GCL products having geotextile backing(s). It is not applicable to GCL products with geomembrane backing(s), geofilm backing(s) or polymer coating backing(s).

1.4 This test method provides measurements of flux and hydraulic conductivity under a prescribed set of conditions, as an index test, that can be used for manufacturing quality control. The flux and hydraulic conductivity values determined using this test method under the prescribed set of conditions is not considered to be representative of the in-service conditions of GCLs. However, the test method allows the requester to establish a set of test conditions; thus, the test method also may be used to check performance or conformance, or both.

1.5 The values stated in SI units are to be regarded as the standard, unless other units are specifically given. By tradition in U.S. practice, hydraulic conductivity is reported in centimeters per second, although the common SI units for hydraulic conductivity are meters per second.

1.6 *This standard does not purport to address all of the safety concerns, if any, associated with its use. It is the responsibility of the user of this standard to establish appropriate*

*and safety and health practices and determine the applicability of regulatory limitations prior to use.*

## 2. Referenced Documents

2.1 *ASTM Standards:*<sup>2</sup>

[D653 Terminology Relating to Soil, Rock, and Contained Fluids](#)

[D2216 Test Methods for Laboratory Determination of Water \(Moisture\) Content of Soil and Rock by Mass](#)

[D4439 Terminology for Geosynthetics](#)

[D4753 Guide for Evaluating, Selecting, and Specifying Balances and Standard Masses for Use in Soil, Rock, and Construction Materials Testing](#)

[D5887 Test Method for Measurement of Index Flux Through Saturated Geosynthetic Clay Liner Specimens Using a Flexible Wall Permeameter](#)

[E145 Specification for Gravity-Convection and Forced-Ventilation Ovens](#)

## 3. Terminology

3.1 *Definitions:*

3.1.1 *flux, n*—the rate of discharge of liquid under laminar flow conditions through a unit cross-sectional area of a GCL specimen at a standard temperature condition ( $22 \pm 3^\circ\text{C}$ ).

3.1.2 *geosynthetic clay liner (GCL), n*—a factory-manufactured geosynthetic hydraulic barrier consisting of clay supported by geotextiles, geomembranes, or a combination thereof, that are held together by needling, stitching, chemical adhesives or other methods.

3.1.3 *hydraulic conductivity, k, n*—the rate of discharge of liquid under laminar flow conditions through a unit cross-sectional area of a GCL specimen under a unit hydraulic gradient and standard temperature conditions ( $22 \pm 3^\circ\text{C}$ ).

3.1.3.1 *Discussion*—The term *coefficient of permeability* is often used instead of *hydraulic conductivity* but *hydraulic conductivity* is used exclusively in this test method. A more

<sup>1</sup> This test method is under the jurisdiction of ASTM Committee [D35](#) on Geosynthetics and is the direct responsibility of Subcommittee [D35.04](#) on Geosynthetic Clay Liners.

Current edition approved July 1, 2012. Published September 2012. Originally approved in 2002. Last previous edition approved in 2009 as D6766-09. DOI: 10.1520/D6766-12.

<sup>2</sup> For referenced ASTM standards, visit the ASTM website, [www.astm.org](http://www.astm.org), or contact ASTM Customer Service at [service@astm.org](mailto:service@astm.org). For *Annual Book of ASTM Standards* volume information, refer to the standard's Document Summary page on the ASTM website.

complete discussion of the terminology associated with Darcy's law is given in the literature.<sup>3</sup>

3.1.4 *index test, n*—a test procedure that may contain bias, but may be used to establish comparable results with respect to the property of interest.

3.1.5 *pore volume of flow, n*—the cumulative quantity of flow into a test specimen divided by the volume of voids in the specimen.

3.2 For definitions of other terms used in this test method, see Terminology **D653** and **D4439**.

#### 4. Significance and Use

4.1 This test method applies to one-dimensional, laminar flow of water or other aqueous solutions, such as chemical solutions, landfill leachate, and contaminated water (here on referred to as test liquid), through saturated/hydrated GCL specimen that is consolidated and permeated under a prescribed or requested set of conditions.

4.2 This test method can be performed to determine if the flux and/or hydraulic conductivity of a GCL specimen exceeds the maximum value stated by the manufacturer or required by the regulatory agencies, or both.

4.3 It is assumed that Darcy's law is valid and that the hydraulic conductivity is essentially unaffected by hydraulic gradient. The validity of Darcy's law may be evaluated by measuring the hydraulic conductivity of the specimen at three different hydraulic gradients; if all measured values are similar (within about 25 %), then Darcy's law may be taken as valid. However, when the hydraulic gradient acting on a test specimen is changed, the state of stress will also change, and, if the specimen is compressible, the volume of the specimen will change. Thus, some change in hydraulic conductivity may occur when the hydraulic gradient is altered, even in cases where Darcy's law is valid.

4.4 This test method provides tools for determining flux and hydraulic conductivity values for a given GCL under the following two different scenarios, which should be specified by the requester:

4.4.1 *Scenario 1—Hydrated/Saturated with Water Prior to Contact with Test Liquid*—This scenario simulates the field conditions where the GCL is well hydrated with water prior to contact with actual test liquid. It should be noted that initial degree of saturation/hydration greatly affects the hydraulic properties of a GCL product. The test has two phases: (Phase 1) hydrate, saturate, consolidate and permeate with water as Test Liquid 1, and (Phase 2) switch to permeation with test liquid as Test Liquid 2.

4.4.2 *Scenario 2—Hydrated/Saturated with Test Liquid (Worst Case)*—This scenario simulates the field conditions where the GCL is in contact with test liquid prior to being fully hydrated with water. It should be noted that this scenario may result in higher flux and hydraulic conductivity values com-

pared to Scenario 1 as chemicals present in test liquid may alter the hydration and hydraulic properties of a GCL product.

4.5 The apparatus used in this test method is commonly used to determine the hydraulic conductivity of soil specimens. However, flux values measured in this test are typically much lower than those commonly measured for most natural soils. It is essential that the leakage rate of the apparatus in this test be less than 10 % of the flux.

#### 5. Apparatus

5.1 *Compatibility*—All parts in contact with the test liquid(s) shall be checked/verified for long-term compatibility. This can be established either based on the available information or by in-house testing.

5.2 *Hydraulic System*—Constant head (Method A), falling head (Methods B and C), or constant rate of flow (Method D) systems may be utilized provided they meet the criteria outlined as follows:

5.2.1 *Constant Head (Method A)*—The system must be capable of maintaining constant hydraulic pressures to within  $\pm 5\%$  and shall include means to measure the hydraulic pressures to within the prescribed tolerance. In addition, the head loss across the tests specimen must be held constant to within  $\pm 5\%$  and shall be measured with the same accuracy or better. Pressures shall be measured by a pressure gage, electronic pressure transducer, or any other device of suitable accuracy.

5.2.2 *Falling Head (Methods B and C)*—The system shall allow for measurement of the applied head loss, thus hydraulic gradient, to within  $\pm 5\%$ . In addition, the ratio of initial head loss divided by final head loss over an interval of time shall be measured such that this computed ratio is accurate to within  $\pm 5\%$ . The head loss shall be measured with a pressure gage, electronic pressure transducer, engineer's scale, graduated pipette, or any other device of suitable accuracy. Falling head tests may be performed with either a falling headwater and constant tailwater elevation (Method B) or a falling headwater and rising tailwater elevation (Method C).

5.2.3 *Constant Rate of Flow (Method D)*—The system must be capable of maintaining a constant rate of flow through the specimen to within  $\pm 5\%$ . Flow measurement shall be by calibrated syringe, graduated pipette, or other device of suitable accuracy. The head loss across the specimen shall be measured to an accuracy of 5 % or better using an electronic pressure transducer or other device of suitable accuracy. More information on testing with a constant rate of flow is given in the literature.<sup>4</sup>

5.2.4 *System De-airing*—The hydraulic system shall be designed to facilitate rapid and complete removal of free air bubbles from flow lines.

5.2.5 *Back Pressure System*—The hydraulic system shall have the capability to apply back-pressure to the specimen to facilitate saturation. The system shall be capable of maintaining the applied back-pressure throughout the duration of

<sup>3</sup> Olson, R. E. and Daniel, D. E. "Measurement of the Hydraulic Conductivity of Fine-Grained Soils," *Symposium on Permeability and Groundwater Contaminant Transport*, ASTM STP 746, ASTM, 1981, pp. 18–64.

<sup>4</sup> Olson, H. W., Morin, R. H., and Nichols, R. W., "Flow Pump Applications in Triaxial Testing," *Symposium on Advanced Triaxial Testing of Soil and Rock*, ASTM STP 977, ASTM, 1988, pp. 68–81.

hydraulic conductivity measurements. The back-pressure system shall be capable of applying, controlling, and measuring the back-pressure to 5 % or better of the applied pressure. The back-pressure may be provided by a compressed gas supply (see Note 1), a deadweight acting on a piston, or any other method capable of applying and controlling the back-pressure to the tolerance prescribed in this paragraph.

NOTE 1—Application of gas pressure directly to a fluid will dissolve gas in the fluid. Any suitable technique, including separation of gas and liquid phases with a bladder, may be used to minimize dissolution of gas in the back-pressure fluid.

5.3 *Flow Measurement System*—Both inflow and outflow volumes shall be measured unless the lack of leakage, continuity of flow, and cessation of consolidation or swelling can be verified by other means. Flow volumes shall be measured by a graduated accumulator, graduated pipette, vertical standpipe in conjunction with an electronic pressure transducer, or other volume-measuring device of suitable accuracy.

5.3.1 *Flow Accuracy*—Required accuracy for the quantity of flow measured over an interval of time is  $\pm 5\%$ .

5.3.2 *De-airing and Compliance of the System*—The flow-measurement system shall contain a minimum of dead space and be capable of complete and rapid de-airing. Compliance of the system in response to changes in pressure shall be minimized by using a stiff flow measurement system. Rigid tubing, such as metallic or rigid thermoplastic tubing, shall be used.

5.3.3 *Head Losses*—Head losses in the tubes, valves, porous end pieces, and filter paper may lead to error. To guard against

such errors, the permeameter shall be assembled with no specimen inside and then the hydraulic system filled. If a constant or falling head test is to be used, the hydraulic pressures or heads that will be used in testing a specimen shall be applied, and the rate of flow measured with an accuracy of 5 % or better. This rate of flow shall be at least ten times greater than the rate of flow that is measured when a GCL specimen is placed inside the permeameter and the same hydraulic pressures or heads are applied. If a constant rate of flow test is to be used, the rate of flow to be used in testing a specimen shall be supplied to the permeameter and the head loss measured. The head loss without a specimen shall be less than 0.1 times the head loss when a GCL specimen is present.

5.4 *Permeant Interface Device (Bladder Accumulator)*—A permeant interface device shall be used when a hazardous/corrosive or volatile test liquid, or both, is to be used as the permeant. The permeant interface device shall contain the test liquid in a closed chamber and allow neither possible contamination of flow measurement and pressure systems nor potential release of chemicals present in the test liquid to the breathing air, while maintaining the desired test pressures. A schematic diagram of a typical permeant interface device is shown in Fig. 1. The device consists of mainly a water chamber and a test liquid chamber, which are separated with a flexible bladder membrane. The device should be checked for leaks at the desired test pressures prior to the testing.

5.5 *Permeameter Cell-Pressure System*—The system for pressurizing the permeameter cell shall be capable of applying

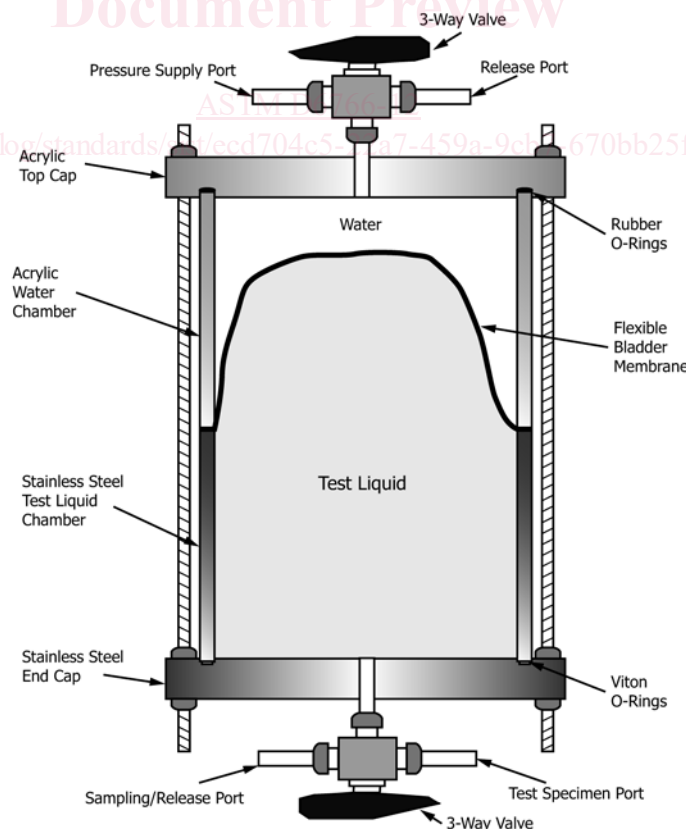

FIG. 1 Schematic Diagram of Permeant Interface Device

and controlling the cell-pressure to within  $\pm 5\%$  of the applied pressure. However, the effective stress on the test specimen (which is the difference between the cell-pressure and the pore water pressure) shall be maintained to the desired value with an accuracy of  $\pm 5\%$  or better. The device for pressurizing the cell may consist of a reservoir connected to the permeameter cell and partially filled with de-aired water, with the upper part of the reservoir connected to a compressed gas supply or other source of pressure (see Note 2). The gas pressure shall be controlled by a pressure regulator and measured by a pressure gage, electronic pressure transducer, or any other device capable of measuring to the prescribed tolerance. A hydraulic system pressurized by dead-weight acting on a piston or any other pressure device capable of applying and controlling the permeameter cell-pressure to the tolerance prescribed in this paragraph may be used.

NOTE 2—De-aired water is commonly used for the cell fluid to minimize potential for diffusion of air through the membrane into the specimen. Other fluids, such as oils, which have low gas solubility are also acceptable, provided they do not react with components of the permeameter. Also, use of a long (approximately 5 to 7 m) tube connecting the pressurized cell liquid to the permeameter cell helps to delay the appearance of air in the cell fluid and to reduce the flux of dissolved air into the cell.

5.6 *Permeameter Cell*—An apparatus shall be provided in which the GCL specimen and porous end pieces, enclosed by a membrane sealed to the cap and base, are subjected to controlled fluid pressures. A schematic diagram of a typical cell is shown in Fig. 2.

5.6.1 The Permeability cell may allow for observation of changes in height of the GCL specimen, either by observation through the cell wall using a cathetometer or other instrument, or by monitoring of either a loading piston or an extensometer extending through the top plate of the cell bearing on the top cap and attached to a dial indicator or other measuring device. The piston or extensometer should pass through a bushing and

seal incorporated into the top plate and shall be loaded with sufficient force to compensate for the cell-pressure acting over the cross-sectional area of the piston where it passes through the seal. If deformations are measured, the deformation indicator shall be a dial indicator or cathetometer graduated to 0.3 mm (0.01 in.) or better and having an adequate travel range. Any other measuring device meeting these requirements is acceptable.

5.6.2 In order to facilitate gas removal, and thus saturation of the hydraulic system, four drainage lines leading to the specimen, two each to the base and top cap, are recommended. The drainage lines shall be controlled by no-volume-change valves, such as ball valves, and shall be designed to minimize dead space in the lines.

5.7 *Top Cap and Base*—An impermeable, rigid top cap and base shall be used to support the specimen and provide for transmission of permeant liquid to and from the specimen. The diameter or width of the top cap and base shall be equal to the diameter or width of the specimen  $\pm 5\%$ . The base shall prevent leakage, lateral motion, or tilting, and the top cap shall be designed to receive the piston or extensometer, if used, such that the piston-to-top cap contact area is concentric with the cap. The surface of the base and top cap that contacts the membrane to form a seal shall be smooth and free of scratches.

5.8 *Flexible Membranes*—The flexible membrane used to encase the specimen shall provide reliable protection against leakage. The membrane shall be carefully inspected prior to use and if any flaws or pinholes are evident, the membrane shall be discarded (see Note 3). To minimize restraint of the specimen, the diameter or width of the unstretched membrane shall be between 90 and 95 % of that of the specimen. The membrane shall be sealed to the specimen base and cap with rubber O-rings for which the unstressed, inside diameter or

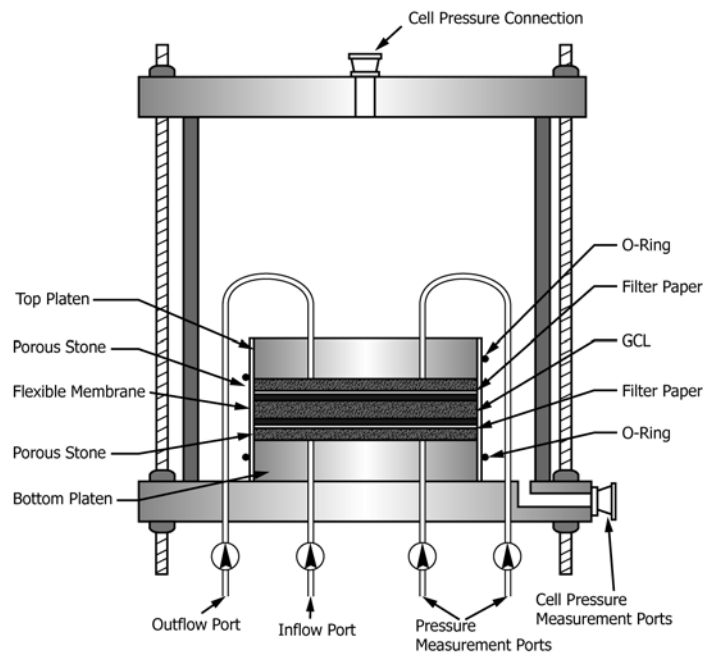

FIG. 2 Schematic Diagram of Permeameter Cell