



Designation: **E1012 – 12 E1012 – 12<sup>ε1</sup>**

# Standard Practice for Verification of Testing Frame and Specimen Alignment Under Tensile and Compressive Axial Force Application<sup>1</sup>

This standard is issued under the fixed designation E1012; the number immediately following the designation indicates the year of original adoption or, in the case of revision, the year of last revision. A number in parentheses indicates the year of last reapproval. A superscript epsilon ( $\epsilon$ ) indicates an editorial change since the last revision or reapproval.

---

<sup>ε1</sup> NOTE—Note 13, 10.2.1, and Eq 14 were editorially corrected in September 2012.

---

## 1. Scope\*

1.1 Included in this practice are methods covering the determination of the amount of bending that occurs during the application of tensile and compressive forces to notched and unnotched test specimens during routine testing in the elastic range. These methods are particularly applicable to the force levels normally used for tension testing, creep testing, and uniaxial fatigue testing. The principal objective of this practice is to assess the amount of bending exerted upon a test specimen by the ordinary components assembled into a materials testing machine, during routine tests.

## 2. Referenced Documents

### 2.1 ASTM Standards:<sup>2</sup>

- E6 Terminology Relating to Methods of Mechanical Testing
- E8 Test Methods for Tension Testing of Metallic Materials
- E9 Test Methods of Compression Testing of Metallic Materials at Room Temperature
- E21 Test Methods for Elevated Temperature Tension Tests of Metallic Materials
- E83 Practice for Verification and Classification of Extensometer Systems
- E251 Test Methods for Performance Characteristics of Metallic Bonded Resistance Strain Gauges
- E466 Practice for Conducting Force Controlled Constant Amplitude Axial Fatigue Tests of Metallic Materials
- E606 Practice for Strain-Controlled Fatigue Testing
- E1237 Guide for Installing Bonded Resistance Strain Gages

### 2.2 Other Documents:

- VAMAS Guide 42 A Procedure for the Measurement of Machine Alignment in Axial Testing

## 3. Terminology

### 3.1 Definitions of Terms Common to Mechanical Testing:

- 3.1.1 For definitions of terms used in this practice that are common to mechanical testing of materials, see Terminology E6.
- 3.1.2 *alignment, n*—the condition of a testing machine that influences the introduction of bending moments into a specimen (or alignment transducer) during the application of tensile or compressive forces.
- 3.1.3 *eccentricity [L], n*—the distance between the line of action of the applied force and the axis of symmetry of the specimen in a plane perpendicular to the longitudinal axis of the specimen.
- 3.1.4 *reduced section [L], n*—section in the central portion of the specimen which has a cross section smaller than the gripped ends.

### 3.2 Definitions of Terms Specific to This Standard:

- 3.2.1 *axial strain, a, n*—the average of the longitudinal strains measured by strain gages at the surface on opposite sides of the longitudinal axis of symmetry of the alignment transducer by multiple strain-sensing devices located at the same longitudinal position.

---

<sup>1</sup> This practice is under the jurisdiction of ASTM Committee E28 on Mechanical Testing and is the direct responsibility of Subcommittee E28.01 on Calibration of Mechanical Testing Machines and Apparatus.

Current edition approved June 1, 2012. Published June 2012. Originally approved in 1989. Last previous edition approved in 2005 as E1012 – 05. DOI: 10.1520/E1012-12.10.1520/E1012-12E01.

<sup>2</sup> For referenced ASTM standards, visit the ASTM website, www.astm.org, or contact ASTM Customer Service at service@astm.org. For Annual Book of ASTM Standards volume information, refer to the standard's Document Summary page on the ASTM website.

\*A Summary of Changes section appears at the end of this standard

3.2.1.1 Discussion—

This definition is only applicable to this standard. The term is used in other contexts elsewhere in mechanical testing.

3.2.2 bending strain,  $b, n$ —the difference between the strain at the surface and the axial strain (see Fig. 1).

3.2.2.1 Discussion—

in general, the bending strain varies from point to point around and along the reduced section of the specimen. Bending strain is calculated as shown in Section 10.

3.2.3 component (also known as force application component),  $n$ —any of the parts used in the attachment of the load cell or grips to the testing frame, as well as any part, including the grips used in the application of force to the strain-gaged alignment transducer or the test specimen.

3.2.4 grips,  $n$ —that part of the force application components that directly attach to the strain-gage alignment transducer or the test specimen.

3.2.5 microstrain,  $n$ —strain expressed in micro-units per unit, such as micrometers/meter or microinches/in.

3.2.6 notched section  $[L]$ ,  $n$ —the section perpendicular to the longitudinal axis of symmetry of the specimen where the cross-sectional area is intentionally at a minimum value in order to serve as a stress raiser.

3.2.7 percent bending,  $PB$ , (also known as percent bending strain),  $n$ —the ratio of the bending strain to the axial strain expressed as a percentage.

3.2.8 strain-gaged alignment transducer,  $n$ —the transducer used to determine the state of bending and the percent bending of a testing frame.

3.2.9 Type 1 alignment,  $n$ —the condition of a testing machine typically used for static or quasi-static testing including the non-rigid components and the positioning of the specimen within the grips which can introduce bending moments into the strain-gaged alignment transducer or test specimen during force application.

3.2.10 Type 2 alignment,  $n$ —the condition of a testing machine typically used for dynamic testing and all rigid parts of the load train which can introduce bending moments into the strain-gaged alignment transducer or test specimen force application.

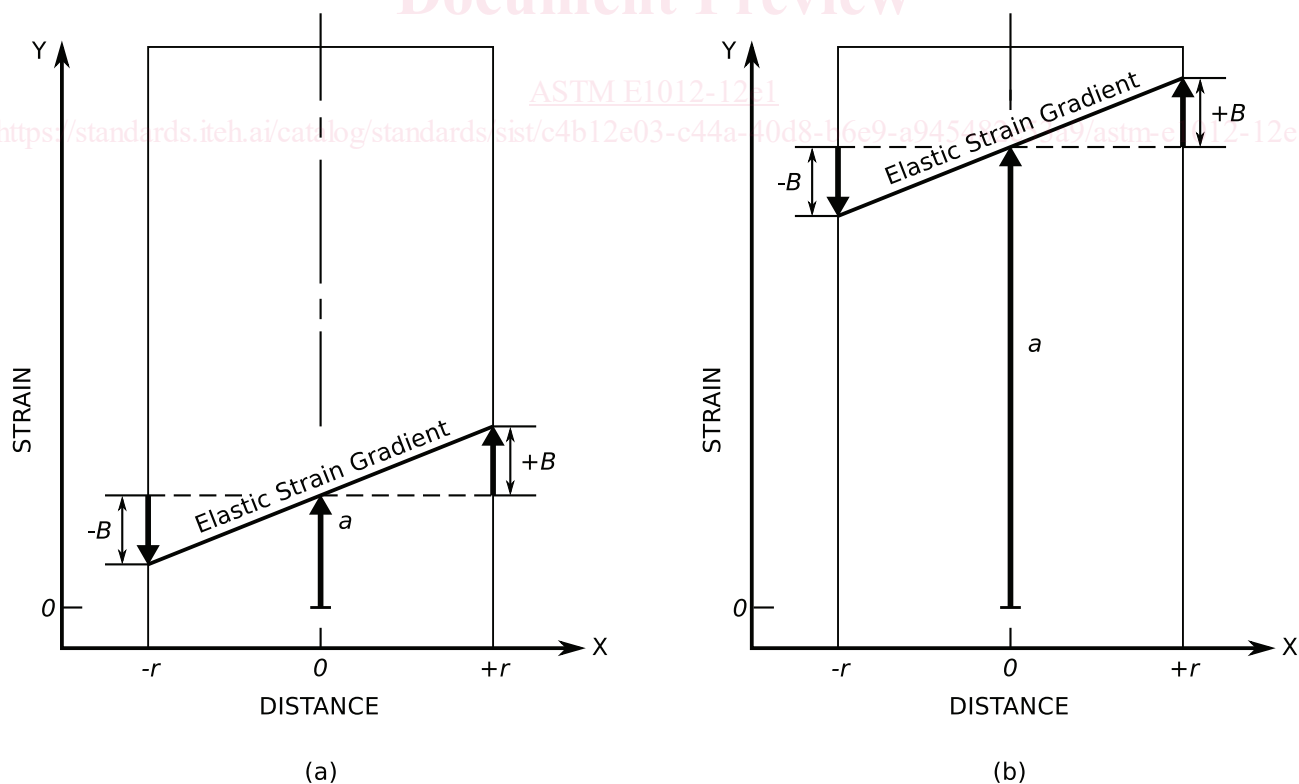

NOTE 1—A bending strain,  $\pm B$ , is superimposed on the axial strain,  $a$ , for low-axial strain (or stress) in (a) and high-axial strain (or stress) in (b). For the same bending strain  $\pm B$ , a high-percent bending is indicated in (a) and a low-percent bending is indicated in (b).

FIG. 1 Schematic Representations of Bending Strains (or Stresses) That May Accompany Uniaxial Loading

## 4. Significance and Use

4.1 It has been shown that bending stresses that inadvertently occur due to misalignment between the applied force and the specimen axes during the application of tensile and compressive forces can affect the test results. In recognition of this effect, some test methods include a statement limiting the misalignment that is permitted. The purpose of this practice is to provide a reference for test methods and practices that require the application of tensile or compressive forces under conditions where alignment is important. The objective is to implement the use of common terminology and methods for verification of alignment of testing machines, associated components and test specimens.

4.2 Alignment verification intervals when required are specified in the methods or practices that require the alignment verification. Certain types of testing can provide an indication of the current alignment condition of a testing frame with each specimen tested. If a test method requires alignment verification, the frequency of the alignment verification should capture all the considerations i.e. time interval, changes to the testing frame and when applicable, current indicators of the alignment condition through test results.

4.3 Whether or not to improve axiality should be a matter of negotiation between the material producer and the user.

## 5. Verification of Alignment

5.1 A numerical requirement for alignment should specify the force, strain-gaged alignment transducer dimensions, and temperature at which the measurement is to be made. Alternate methods employed when strain levels are of particular importance may be used as described in Practices E466 or E606. When these methods are used, the numerical requirement should specify the strain levels, strain-gaged alignment transducer dimensions and temperature at which the measurement is to be made.

NOTE 1—For a misaligned load train, the percent bending usually decreases with increasing applied force. (See Curves A, B, and C in Fig. 2.) However, in some severe instances, percent bending may increase with increasing applied force. (See Curve D in Fig. 2.)

5.2 For a verification of alignment to be reported in compliance with the current revision of E1012 a strain-gaged alignment transducer shall be used. This applies to both Type 1 and Type 2 levels of alignment verification.

5.2.1 This standard defines two types of classified testing machine alignment per the classification criteria. The type of alignment shall be noted on the report.

5.2.2 When performing an alignment of a testing machine for the first time or if normally fixed components have been adjusted or repaired, a mechanical alignment of the testing machine should be performed. For tensile and fatigue equipment, this step can be accomplished by means of a dial indicator for concentricity alignment adjustment and with precision shims or feeler gauges with the components brought together for angularity alignment adjustment. For creep and stress-rupture machines incorporating lever arms, this step may be accomplished by means of precision shims or feeler gauges, and/or double knife-edge couplings, and/or suitable components below the lower crosshead of the testing machine. Severe damage may occur to a strain-gaged alignment transducer if this step is omitted. A Mechanical Alignment is a preliminary step, but is not a substitute for a verification of alignment using a strain-gaged alignment transducer.

5.3 *Testing Machine Alignment Type 1*—A general alignment verification of the defined load train components. It is understood that some parts of the testing machine (i.e. the crosshead, actuator or grip faces) may be moved or exchanged in normal day to day testing. This alignment verification should be conducted for the various changes to the system (i.e. adjusting the crosshead and actuator position) to demonstrate reproducibility between changing conditions. Whenever possible the alignment verification should be conducted with the testing system components at a physical position that would simulate the position in which a test specimen would be installed. The strain-gaged alignment transducer geometry and material shall be adequately referenced in the verification report.

NOTE 2—Type 1 typically refers to static test equipment, such as tensile, stress rupture, or creep machines.

NOTE 3—For creep and stress rupture machines, the lever arm should be in a level position when performing alignment verification.

5.3.1 For some material testing, it is not possible or feasible to use all parts of the force application components when verifying alignment. In such cases alternative components may be used. The use of alternative components shall be adequately referenced in the verification report.

5.4 *Testing Machine Alignment Type 2*—Grip-to-grip alignment verification, where the testing machine mechanical configuration is fixed and will not be changed or adjusted during the testing period. However, when testing some specimen geometries, it may be necessary to move the actuator or crosshead to install the strain-gaged alignment transducer and/or test specimens. This should be avoided if possible, but if it is necessary, care should be taken to reposition the actuator and or crosshead in the position used during the alignment. Any removable components specific to the test specimen should be assembled within the aligned grip set and a strain-gaged alignment transducer used for verification of compliance to E1012.

5.4.1 Precision machined grip housings with hydraulic or pneumatically actuated wedge inserts are commonly used in laboratory testing. These devices are specifically designed to allow for interchangeability of wedge inserts without adversely affecting the alignment of the loading train. For testing systems using these gripping configurations, grip wedge inserts may be replaced with smooth wedge inserts to assess the alignment of the testing machine under a Type 2 alignment assessment.

NOTE 4—Type 2 typically refers to dynamic test equipment, such as fatigue testing machines.

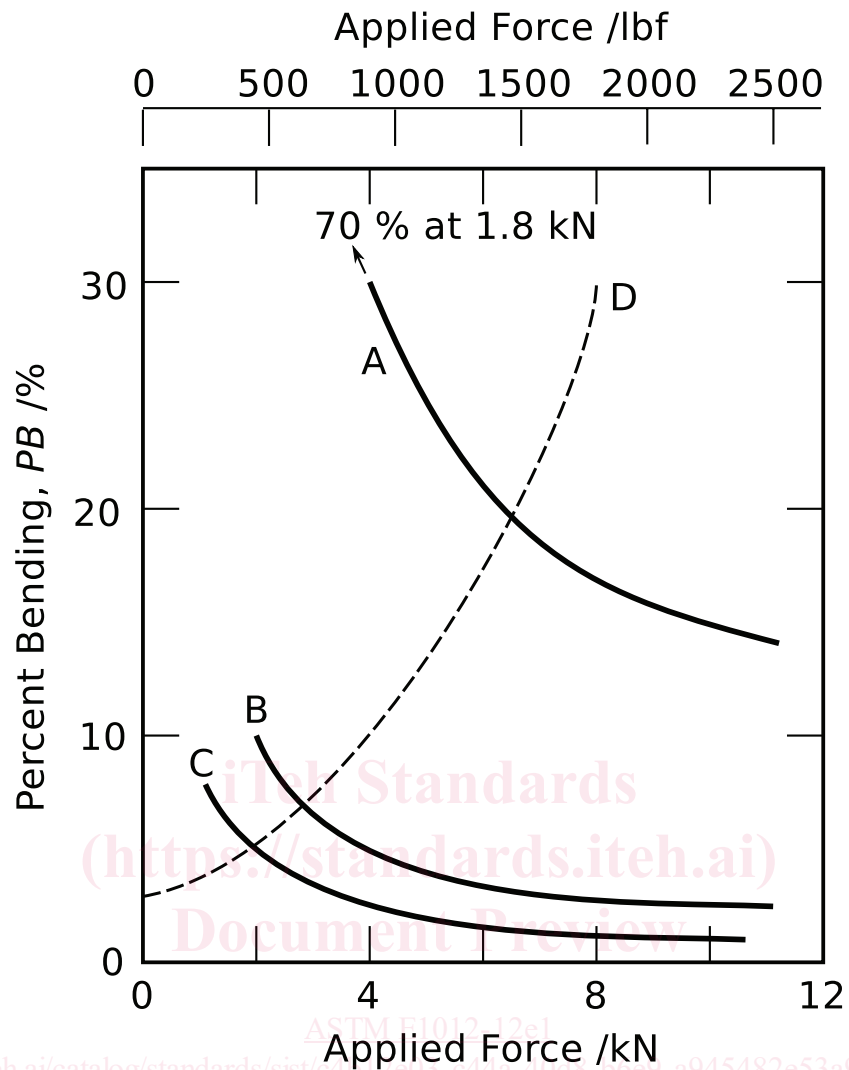

NOTE 1—Curve A: Machine 1, threaded grip ends (11)

NOTE 2—Curve B: Machine 2, buttonhead grip ends (11)

NOTE 3—Curve C: Machine 3, grips with universal couplings (7)

NOTE 4—Curve D: schematic representation of a possible response from a concentrically misaligned load train (16)

**FIG. 2 Effects of Applied Force on Percent Bending for Different Testing Machines and Gripping Methods**

NOTE 5—Type 2 alignment requires as many of the adjustable components of the testing machine as possible to be positioned in the final verified position. This could include adjustable reaction components (i.e. crosshead) and actuators, which may otherwise be free to rotate about the loading axis.

5.5 Strain-gaged alignment transducers shall be manufactured per Section 7 of this standard. The strain-gaged alignment transducer is to be manufactured per section 7.4 as closely as possible, except that any notches may be eliminated. The same strain-gaged alignment transducer may be used for successive verifications. The materials and design should be such that only elastic strains occur at the applied forces.

5.5.1 Strain-gaged alignment transducers shall be used for both Type 1 and Type 2 Testing Machine Alignment.

## 6. Apparatus

6.1 This standard requires the use of a strain-gaged alignment transducer. In some cases it may be helpful to make an assessment using extensometers or alignment components employing mechanical linkages (see Appendix X2), however these types of strain sensors do not meet the reporting requirements in Section 11.

6.2 In general, repeated force applications to strain levels approaching yielding are not good laboratory practice because they may affect the subsequently measured results by deforming or fatiguing the strain-gaged alignment transducer.

6.3 *Additional Testing Machine and Force Application Component Considerations:*

6.3.1 Poorly made components and multiple interfaces in a load train can cause major difficulty in attempting to align a test system. All components in the load train should be machined within precision machining practices with attention paid to perpendicularity, concentricity, flatness and surface finish. The number of components should be kept to a minimum.

6.3.2 Situations can arise where acceptable alignment cannot be achieved for a given testing machine, set of force application components and strain-gaged alignment transducer. In these cases, redesign and fabrication of any of the components may be needed to achieve acceptable alignment.

## 7. Strain-Gaged Alignment Transducer

7.1 This practice refers to cylindrical strain-gaged alignment transducers, thick rectangular strain-gaged alignment transducers, and thin rectangular strain-gaged alignment transducers. The actual strain-gaged alignment transducer geometry is dictated by the test standard to be used. These strain-gaged alignment transducers are usually dog-bone shaped with a reduced gauge section, although other strain-gaged alignment transducers such as those used for compression testing are acceptable.

NOTE 6—Since fabricating a strain-gaged alignment transducer can be a time consuming and expensive process it is best to have this step planned out well in advance of needing the strain-gaged alignment transducer.

NOTE 7—For notched specimens, it is acceptable to use a strain-gaged alignment transducer that simulates the anticipated test specimen without the notch.

7.2 This practice is valid for metallic and nonmetallic testing.

7.3 Quality of machining of alignment transducers is critical. Important features include straightness, concentricity, flatness, and surface finish. In particular, strain-gaged alignment transducers used for compression testing may be of the type that uses two parallel plates to apply compression to the ends of the strain-gaged alignment transducer. In these cases, the parallelism of the strain-gaged alignment transducer ends is extremely important as described in Test Methods E9.

7.4 The design of a strain-gaged alignment transducer should follow the same guidelines as design of standard test specimens. For static (tensile, compressive and creep) testing, strain-gaged alignment transducers conforming to test specimens shown in Test Methods E8 are appropriate. For fatigue testing applications, strain-gaged alignment transducers conforming to test specimens shown in Practice E606 are appropriate. The strain-gaged alignment transducer should be as close dimensionally to the expected test specimens as possible so that the same force application components to be used during testing will be used during alignment. The material used for the strain-gaged alignment transducer should be as close as possible to expected test specimen materials. If the expected test material is not known, it is acceptable to use a strain-gaged alignment transducer of a common material that has similar elastic properties to expected test materials. The alignment transducer should be carefully inspected and the dimensions recorded prior to application of the strain gages.

NOTE 8—It is common laboratory practice to employ an alternate material for the strain-gaged alignment transducer in order to be able to use the strain-gaged alignment transducer for a number of repeated alignment verifications. The alternate material used should be such that the strain-gaged alignment transducer maintains its elastic properties through the loading range of interest encountered in the alignment verification (i.e. the strain-gaged alignment transducer remains below its proportional limit). A common upper strain limit for these strain-gaged alignment transducers is 3000 microstrain maximum.

7.5 Strain Gages should be selected that have known standardized performance characteristics as described in Test Methods E251. Strain gage manufacturers provide detailed information about the strain gages available. Gages with gauge lengths of approximately 10 % of the reduced section of the alignment transducer or less should be selected. The gages should be as small as practical to avoid any strain averaging effects with adjacent gages. Temperature compensated gages that are all of the same type and from the same batch (same gage factor, transverse sensitivity and temperature coefficient) should be used.

7.6 Strain gages should be installed according to procedures in Guide E1237. A commonly used method for marking the intended strain gage locations on the alignment transducer is to precisely scribe shallow longitudinal marks and transverse marks where the strain gages are to be applied. The gages are then aligned with the scribe marks when bonding. The gage placements can be inspected after installation.

7.6.1 Surface preparation for strain gage bonding can influence mechanical properties. The strain-gaged alignment transducer should not be expected to exhibit the same mechanical properties as a standard test specimen would.

### 7.7 Configuration of Strain-Gaged Alignment Transducers:

NOTE 9—External specifications and requirements may dictate specific configuration for number of gages and gage spacings.

7.7.1 The cross section of a strain-gaged alignment transducer may be cylindrical, thick rectangular (those with width to thickness ratio of less than three) or thin rectangular (those with width to thickness ratio of three or larger). Strain-gaged alignment transducers should have a minimum of two sets of four gages, but in some cases may have two sets of three gages. A third set of strain gages may be added to provide additional information. A single set of gages is acceptable in some cases. Fig. 3 shows the configurations of these strain-gaged alignment transducers.

#### 7.7.2 Requirements for Cylindrical Strain-Gaged Alignment Transducers:

7.7.2.1 For strain-gaged alignment transducers with reduced section length 12 mm (0.5 in) or greater two sets of four gages are acceptable. An additional set of gages at the center of the reduced section A, is also acceptable and can provide additional

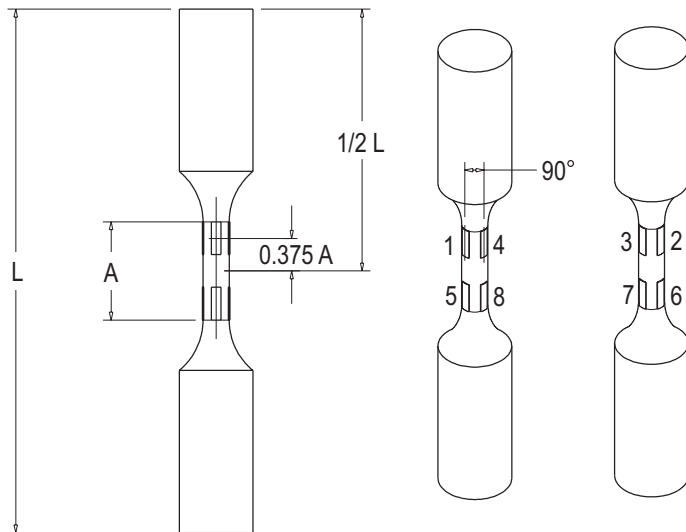

Cylindrical 90° Spacing  
Figure A

FIG. 3 A Locations of Strain Sensors on (A) Cylindrical, (B) Thick rectangular and (C) Thin Rectangular Strain-Gaged Alignment transducers (Numbers Indicate Positions of Strain Sensors)

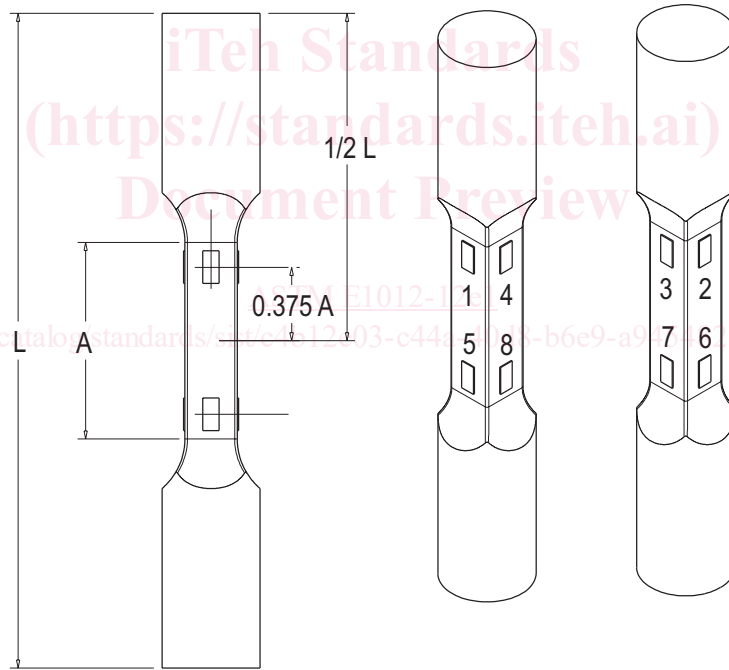

Thick Rectangular  
Figure B

FIG. 3 B Locations of Strain Sensors on (A) Cylindrical, (B) Thick rectangular and (C) Thin Rectangular Strain-Gaged Alignment transducers (Numbers Indicate Positions of Strain Sensors) (continued)

information. For strain-gaged alignment transducers with reduced section length,  $A$ , less than 12 mm (0.5 in), a single set of strain gages in the center of the length of the reduced section is acceptable.

7.7.2.2 Cylindrical strain-gaged alignment transducers may have sets of either three gages or four gages. Four-gage configurations shall have gages equally spaced at 90 degrees around the circumference of the strain-gaged alignment transducer. Three-gage configurations shall have gages equally spaced at 120 degrees around the circumference of the strain-gaged alignment transducer.



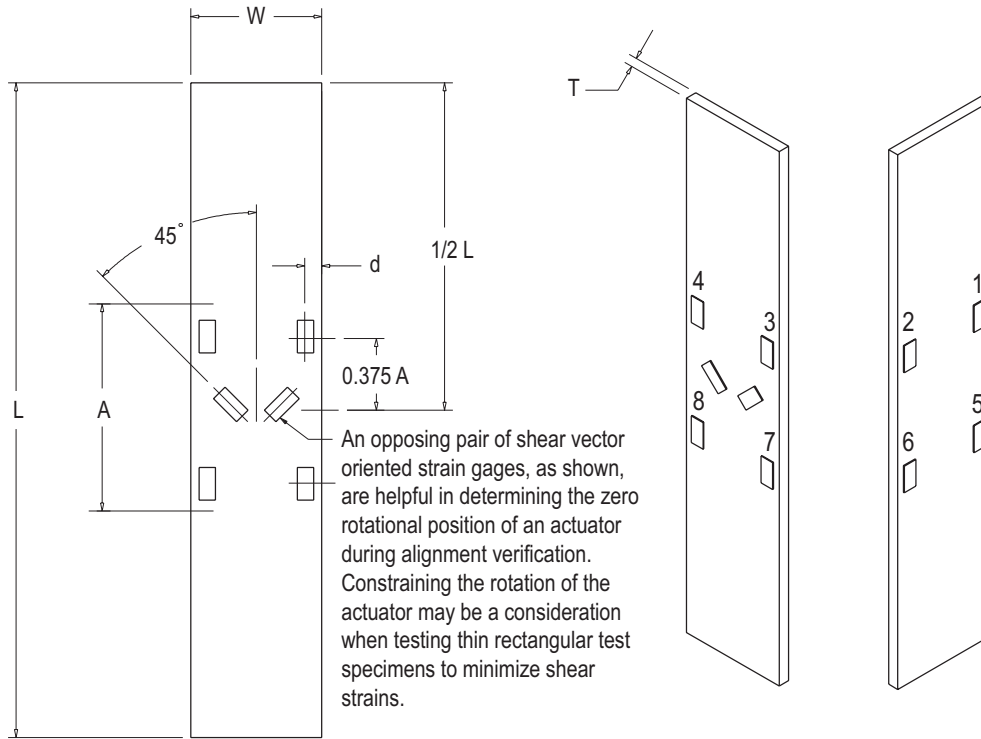

Thin Rectangular  
Figure C

FIG. 3 C Locations of Strain Sensors on (A) Cylindrical, (B) Thick rectangular and (C) Thin Rectangular Strain-Gaged Alignment transducers (Numbers Indicate Positions of Strain Sensors) (continued)

NOTE 10—With three-gage, 120 degree spaced configurations it can be more difficult to detect a malfunctioning gage.

7.7.2.3 In a two set strain-gaged alignment transducer the gages shall be placed equidistant from longitudinal center at a distance  $A_3 = 0.375 A$ . In a three gage set strain-gaged alignment transducer one set of gages shall be placed at the longitudinal center of the alignment transducer and the other two shall be placed at a distance  $A_3 = 0.375 A$  from the longitudinal center of the alignment transducer. In a one gage set strain-gaged alignment transducer, the gages shall be placed on the longitudinal center of the alignment transducer.

7.7.3 Requirements for Thick Rectangular Strain-Gaged Alignment Transducers:

7.7.3.1 For strain-gaged alignment transducers with reduced section length 12 mm (0.5 in) or greater two sets of four gages are acceptable. An additional set of gages at the center of the reduced section  $A$ , is also acceptable and can provide additional information. For strain-gaged alignment transducers with reduced section length,  $A$ , less than 12 mm (0.5 in), a single set of strain gages in the center of the length of the reduced section is acceptable. Thick rectangular strain-gaged alignment transducers shall have gages equally positioned on all four faces of the strain-gaged alignment transducer.

7.7.3.2 In a two gage set strain-gaged alignment transducer the gages shall be placed equidistant from longitudinal center at a distance  $A_3 = 0.375 A$ . In a three gage set strain-gaged alignment transducer one set of gages shall be placed at the longitudinal center of the alignment transducer and the other two shall be placed at a distance  $A_3 = 0.375 A$  from the longitudinal center of the alignment transducer. In a one gage set strain-gaged alignment transducer, the gages shall be placed on the longitudinal center of the alignment transducer.

NOTE 11—For thick rectangular strain-gaged alignment transducers, the differences in adjacent dimensions of the gage section can lead to differences in the sensitivities of gages on these surfaces. This in turn can lead to difficulties in making adjustments to bring a test setup into good alignment.

7.7.4 Requirements for Thin Rectangular Strain-Gaged Alignment Transducers:

7.7.4.1 For strain-gaged alignment transducers with reduced section length 12 mm (0.5 in.) or greater two sets of four gages are acceptable. An additional set of gages at the center of the reduced section  $A$ , is also acceptable and can provide additional information. For strain-gaged alignment transducers with reduced section length,  $A$ , less than 12 mm (0.5 in.), a single set of strain gages in the center of the length of the reduced section is acceptable.

7.7.4.2 Thin rectangular strain-gaged alignment transducers shall have sets of 4 gages equally spaced on the two wide faces of the strain-gaged alignment transducer. Gages shall be in the same position on both faces of the strain-gaged alignment transducer.

In a two gage set strain-gage alignment transducer the gages shall be placed equidistant from longitudinal center at a distance  $A_3 = 0.375 A$ . In a three gage set strain-gaged alignment transducer one set of gages shall be placed at the longitudinal center of the alignment transducer and the other two shall be placed at a distance  $A_3 = 0.375 A$  from the longitudinal center of the alignment transducer. In a one gage set strain-gaged alignment transducer, the gages shall be placed on the longitudinal center of the strain-gaged alignment transducer.

NOTE 12—An opposing pair of shear vector oriented strain gages, as shown in Fig. 3C, are helpful in determining the zero rotational position of an actuator during alignment verification. Constraining the rotation of the actuator may be a consideration when testing thin rectangular test specimens to minimize shear strains.

## 8. Calibration and Standardization

8.1 All conditioning electronics and data acquisition devices used for the determination of testing system alignment shall be calibrated where applicable. The calibration results shall be traceable to the National Institute of Standards and Technology (NIST) or another recognized National Metrology Institute. Overall system expected performance should be no more than 1/3rd the Expected Class Accuracy from Table 1.

NOTE 13—Where the 100 microstrain fixed limit criteria is invoked, the system would have to measure strain to at least  $\pm 33$  microstrain.

8.1.1 Calibration of strain-gaged alignment transducers is not required by this standard. Traceable national standards do not generally exist for such calibrations. However, great care should be taken in the manufacture of strain-gage alignment transducers used for the determination of alignment. With the exception of cases where the strain-gaged alignment transducer is bent, the sources of measurement error due to individual gage misalignment and differences in gage sensitivity can be minimized by acquiring rotational and repeatability data runs.

8.2 Strain gages should conform to the requirements of Test Methods E251.

## 9. Procedure

9.1 Temperature variations during the verification test should be within the limits specified in the methods or practices which require the alignment verification.

9.2 *Mechanical Alignment*—This section describes the initial alignment of the rigid parts of the components. Mechanical alignment is usually established when setting up a particular type of rigid component configuration on a testing machine. While it often does not change appreciably over time, shock from catastrophic failure in the load train (within the components or test specimen) or wear may establish the need to measure and readjust the testing machine alignment. Before continuing with subsequent Type 1 and Type 2 alignment verification, the mechanical alignment should be checked to ensure that it is acceptable.

9.2.1 Inspect all components for proper mating of bearing surfaces and with the strain-gaged alignment transducer. This includes but is not limited to concentricity, perpendicularity and parallelism measurements. Other measurements may be needed for specific types of grips. Re-machine out of tolerance components.

9.2.2 Assemble the rigid portion of the components, and inspect the position of the components on one end of the specimen attachment point with respect to the position of the components on the other end of the opposite specimen attachment point. This is often done with a dial indicator setup that allows the user to establish both linear (concentric or parallel) and angular differences between the centerlines of the components on each end of the specimen attachment points. Fig. 4 illustrates linear (concentric and parallel) and angular differences between the components on the two ends of the rigid portion of the testing machine. Special alignment components may also be employed. Specific tolerances are beyond the scope of this standard, but should adequate alignment be unachievable, misalignment of these components may be the reason. Testing machines that allow the user to adjust the position of the normally fixed crosshead should be set up in the position that will be used during testing. Movement of the normally fixed crosshead during testing can affect alignment results. If moving the normally fixed crosshead during routine testing (that is, between specimens) is needed, the inspection should be performed several times to assure that movement can be made and the crosshead repositioned to the same location without appreciably affecting alignment.

9.2.3 Adjust the position of the components on one end of the specimen attachment point with respect to the position of the components on the other end of the opposite specimen attachment point to minimize the perpendicularity and the concentricity (cylindrical specimens) and parallelism (flat specimens) errors. This may require loosening the components of one end, tapping or shimming it into position and retightening it.

9.3 Both Type 1 and Type 2 Alignments require the use of a strain-gaged alignment transducer. The strain-gaged alignment transducer is discussed in Section 7.

9.3.1 *Type 1 Alignment*—Type 1 alignment refers to the positioning and subsequent alignment with the strain-gaged alignment transducer and all the non-rigid components in the load train. This is the final alignment verification step for testing machines where the components are not locked in place for testing.

9.3.2 *Type 2 Alignment*—Type 2 alignment refers to the positioning and subsequent alignment with the strain-gaged alignment transducer and all the rigid components in the load train and includes a step where non rigid components become rigid through a locking process. This is the final alignment step for testing machines where the components are locked in place for testing.



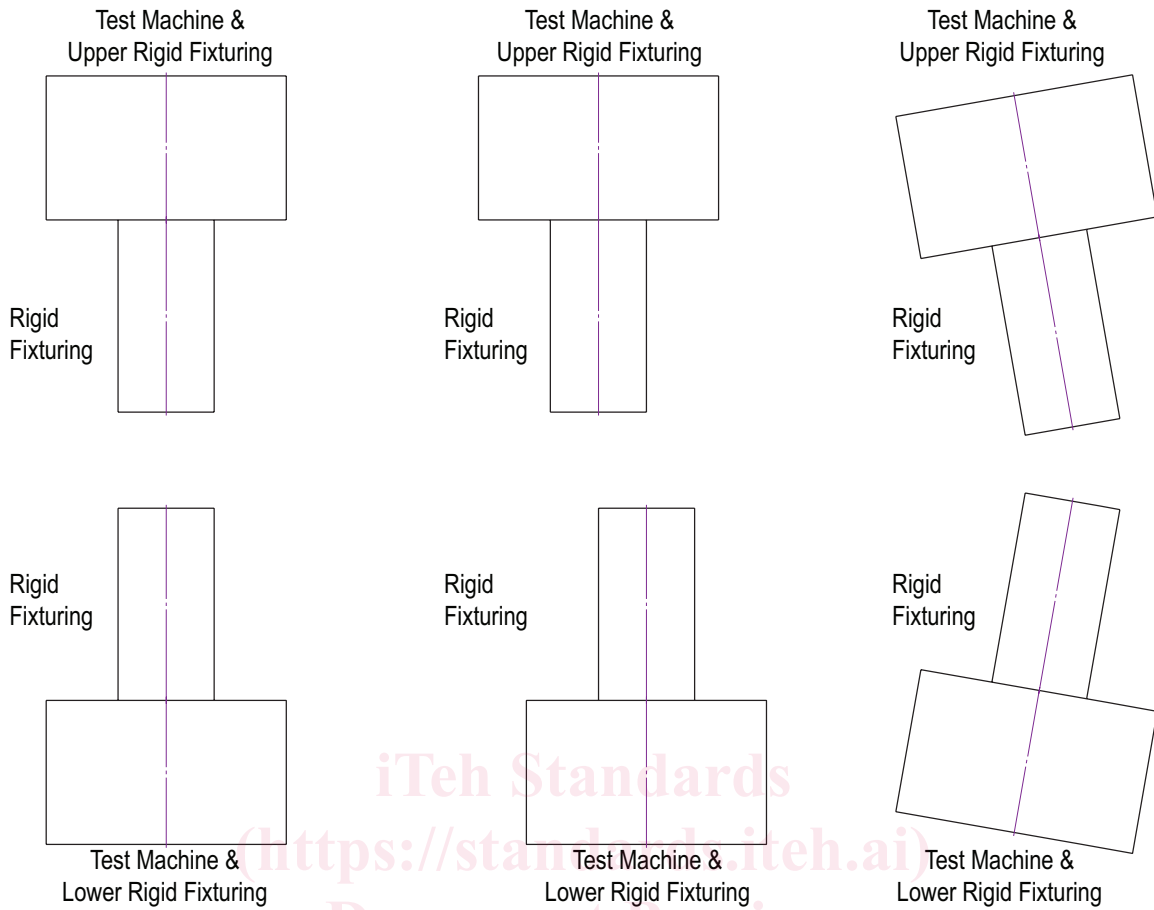

**FIG. 4 Illustration of Testing Machine**  
**(A) Properly Aligned Test Frame and Rigid Fixturing**  
**(B) With Concentric Misalignment between Top and Bottom Fixturing**  
**(C) Angular Misalignment between Top and Bottom Fixturing**

<https://standards.iteh.ai/catalog/standards/sist/c4b12e03-c44a-40d8-b6e9-a945482e53a9/astm-e1012-12e1>

9.3.3 Inspect any components not already inspected as in 9.2.1 (the non-rigid parts of the assembly). Establish the position of the strain-gaged alignment transducer for component setups with non-rigid members by assembling the inspected parts of the load train. Connections, including the strain-gaged alignment transducer should fit smoothly together with no extra play. Re-machine specific parts components if necessary.

9.3.4 Mark the position of any portion of the force application components that will be moved (that is, unthreaded or otherwise repositioned) during the course of normal testing relative to the fixed portion of the components. This is to assure that the components can be put together the same way each time.

9.3.5 Install the strain-gaged alignment transducer into the assembly with only one end attached to the set of grips. Zero the strain readings with no force applied. The act of gripping a strain-gaged alignment transducer on both ends can introduce excessive bending.

9.3.6 Attach the strain-gaged alignment transducer to the remaining grip. The strain-gaged alignment transducer shall not be re-zeroed with both grips attached.

NOTE 14—This is typically the step where Type 2 Alignment Verifications include a load train and specimen locking process.

9.3.7 Apply a small force to make sure all sensors are reading properly and then remove the force.

9.3.8 Imperfect alignment transducer correction. All strain-gaged alignment transducers have some imperfections, either dimensionally or in the attachment of the strain gage. If the strain-gaged alignment transducer is suspected of imparting a large bending effect within the alignment verification, use the procedure in Annex A1 to determine the alignment transducer correction. However, the determination and use of an alignment transducer correction is optional.

9.3.9 Plan the force application cycle such that the testing machine applies the maximum force expected during routine testing, but without exceeding the elastic limit of the alignment transducer. The actual force level in these cases should be agreed upon with the customer and documented. This may be a tensile force, a compressive force, or both. The force may be applied either manually or automatically. While several force application cycles may be helpful for system checks, only a single cycle is required for recording alignment data.

NOTE 15—Additional force cycles can help exercise the strain-gaged alignment transducer and load train and establish hysteresis if using both tension and compression. Strain readings from the initial cycle should be carefully observed to prevent potential damage to the strain-gaged alignment transducer in the case of a poorly aligned testing machine.

9.3.10 Collect alignment data by applying the force in at least three discrete points through the loading range of interest. These should be evenly spaced through the force cycle. During collection of the discrete data points, the force on the strain-gaged alignment transducer shall not vary by more than 1%. For Type 2 alignment verification where both tension and compression are to be used, record data in a similar manner for both. When using mechanical or hydraulic grips that lock the strain-gaged alignment transducer in place, record the strain at zero applied force before and after the locking mechanisms have been engaged. This shows the influence of the locking mechanism on the bending of the strain-gaged alignment transducer.

NOTE 16—There are three recommended practices for establishing the three (or more) discrete points at which alignment verification data is collected: (1) record data points at 1000, 2000 and 3000 nominal microstrain in addition to the check at zero applied force (typically used for Type 2 verifications);

(2) record data at 10%, 20% and 40% of the force transducer range or testing machine capacity in addition to the check at zero applied force (typically used for Type 1 verifications);

(3) record data points within a force range established by the expected yield strengths of materials to be tested on the testing machine in addition to the check at zero applied force (also typically used for Type 1 verifications).

NOTE 17—The data point at zero applied force is intended to record the values of the strain gages with respect to one another and refers to the fixed limit in Fig. 5. There is no need to calculate percent bending at zero applied force.

9.3.11 Remove and reposition the strain-gaged alignment transducer in the grips at additional orientations as needed. At a minimum, measure and record strains under the force cycle described in 9.3.9 in the original orientation, 180 degrees (or 120 degrees for three gage strain-gaged alignment transducers) and again back in the original orientation, unless otherwise specified in external requirements. Installing the strain-gaged alignment transducer in the same orientation as it previously was installed will provide information on repeatability of the strain-gaged alignment transducer. Installing the strain-gaged alignment transducer in another orientation (that is, rotating it or inverting it) will further characterize the alignment of the force application components. Strain-gaged alignment transducers always have some eccentricity, though preparation as described in Section 7 will minimize this. Strain-gaged alignment transducers can be damaged or bent over time and use. Careful handling and storage will minimize this. If the strain-gaged alignment transducer is suspected of imparting a large bending effect within the alignment verification, use the procedure in Annex A2 to separate the alignment transducer contribution and the testing machine alignment contribution from the overall alignment. However, the determination and use of an alignment transducer/testing machine contribution is optional.

9.3.12 Calculate the percent bending for the desired measurement points in the force application cycle using the formulas given in Section 10. If there are significant differences between the verification data in the original orientation versus the 180° (120° for a three gage set) orientation, this condition may be due to a problem with the strain-gaged alignment transducer. If the strain-gaged alignment transducer is suspected of imparting a large bending effect within the alignment verification, use the procedure outlined in Annex A2 to separate the alignment transducer contribution and the testing machine alignment contribution from the overall alignment. However, the determination and use of an alignment transducer/testing machine contribution is optional.

9.3.13 If the calculated percent bending does not meet requirements from the test specification, adjustments, repairs or other improvements will need to be made. Refer to step 9.2 for guidance.

9.3.14 Small adjustments can have a significant effect on the measurements. Adjustments are typically made at 90-degree intervals around the strain-gaged alignment transducer.

9.3.15 Alignment transducers exhibiting induced bending in the shape of an “S” (see Fig. 6) require adjustments to be made to the concentricity (for cylindrical alignment transducers) or perpendicularity (for flat alignment transducers) of the force application components.

9.3.16 Alignment transducers exhibiting induced bending in the shape of a “C” (see Fig. 6) require adjustments to the angularity of the force application components.

NOTE 18—Both the concentricity and angularity adjustments are often required to achieve good alignment.

9.3.17 When adjustments are completed, perform force application cycle again as in 9.3.5, record strain information as in 9.3.6 through 9.3.11 and perform calculations as in 9.3.12. Reassess alignment quality as in 9.3.13 and readjust again as necessary.

## 10. Calculation and Interpretation of Results

10.1 Results of interest usually include axial strain, local bending strains, maximum bending strain, and percent bending. Calculate these for each plane of strain gages.

10.1.1 Local and maximum bending strains seen in an alignment verification may be attributed to a specimen contribution, a testing machine contribution or both.

10.2 *Cylindrical Strain-Gaged Alignment Transducers:*

10.2.1 *Three Strain Sensors*—For strain-gaged alignment transducers of circular-cross section with planes of three strain gages equally spaced around the circumference of the gage length, calculate the axial strain,  $a$ , as:

$$\text{axial strain, } a = \frac{(e_1 + e_2 + e_3)}{3} \quad (1)$$