



Designation: D4554 – 12

# Standard Test Method for In Situ Determination of Direct Shear Strength of Rock Discontinuities<sup>1</sup>

This standard is issued under the fixed designation D4554; the number immediately following the designation indicates the year of original adoption or, in the case of revision, the year of last revision. A number in parentheses indicates the year of last reapproval. A superscript epsilon ( $\epsilon$ ) indicates an editorial change since the last revision or reapproval.

## 1. Scope\*

1.1 This test method covers the measurement of peak and residual direct shear strength in a drained condition of in situ rock discontinuities as a function of stress normal to the sheared plane. This sheared plane is usually a significant discontinuity that may or may not be filled with gouge or soil-like material.

1.2 The measured shear properties are affected by scale factors. The severity of the effect of these factors must be assessed and applied to the specific problems on an individual basis.

1.3 The values stated in SI units are to be regarded as the standard. No other units of measurements are included in this standard.

1.4 All observed and calculated values shall conform to the guidelines for significant digits and rounding established in Practice D6026.

1.5 *This standard does not purport to address all of the safety concerns, if any, associated with its use. It is the responsibility of the user of this standard to establish appropriate safety and health practices and determine the applicability of regulatory limitations prior to use.*

## 2. Referenced Documents

2.1 *ASTM Standards:*<sup>2</sup>

D422 Test Method for Particle-Size Analysis of Soils

D653 Terminology Relating to Soil, Rock, and Contained Fluids

D2216 Test Methods for Laboratory Determination of Water (Moisture) Content of Soil and Rock by Mass

D3740 Practice for Minimum Requirements for Agencies Engaged in Testing and/or Inspection of Soil and Rock as

Used in Engineering Design and Construction

D4318 Test Methods for Liquid Limit, Plastic Limit, and Plasticity Index of Soils

D6026 Practice for Using Significant Digits in Geotechnical Data

D6913 Test Methods for Particle-Size Distribution (Gradation) of Soils Using Sieve Analysis

## 3. Terminology

3.1 *Definitions:*

3.1.1 For definitions of terms used in this test method refer to Terminology D653.

3.2 *Definitions of Terms Specific to This Standard:*

3.2.1 *discontinuities*—any surface across which some property of the rock mass is not continuous. Discontinuities include joints, schistosity, faults, bedding planes, cleavage, and zones of weakness, along with any filling material.

3.2.2 *peak shear strength*—the maximum shear stress in the complete curve of stress versus displacement obtained for a specified constant normal stress.

3.2.3 *residual shear strength*—the shear stress at which nominally no further rise or fall in shear strength is observed with increasing shear displacement and constant normal stress as shown in Fig. 1. A true residual strength may only be reached after considerably greater shear displacement than can be achieved in testing. The test value should be regarded as approximate and should be assessed in relation to the complete shear stress – displacement curve.

3.2.4 *shear strength parameter,  $c$* —apparent cohesion; the projected intercept on the shear stress axis of the plot of shear stress versus normal stress as shown in Fig. 2.

3.2.5 *shear strength parameter,  $\phi$* —friction angle; the angle of the tangent to the failure curve at a normal stress that is relevant to design as shown in Fig. 2.

3.2.5.1 *Discussion*—Different values of  $c$  and  $\phi$  relate to different stages of a test, for example,  $c'$ ,  $c_r'$ ,  $\phi_a$ , and  $\phi_b$ , of Fig. 2.

## 4. Summary of Test Method

4.1 This test method is performed on rectangular-shaped blocks of rock that are isolated on all surfaces, except for the shear plane surface.

<sup>1</sup> This test method is under the jurisdiction of ASTM Committee D18 on Soil and Rock and is the direct responsibility of Subcommittee D18.12 on Rock Mechanics.

Current edition approved Aug. 1, 2012. Published November 2012. Originally approved in 1985. Last previous edition approved in 2006 as D4554 – 02 (2006). DOI: 10.1520/D4554-12.

<sup>2</sup> For referenced ASTM standards, visit the ASTM website, www.astm.org, or contact ASTM Customer Service at service@astm.org. For *Annual Book of ASTM Standards* volume information, refer to the standard's Document Summary page on the ASTM website.

\*A Summary of Changes section appears at the end of this standard

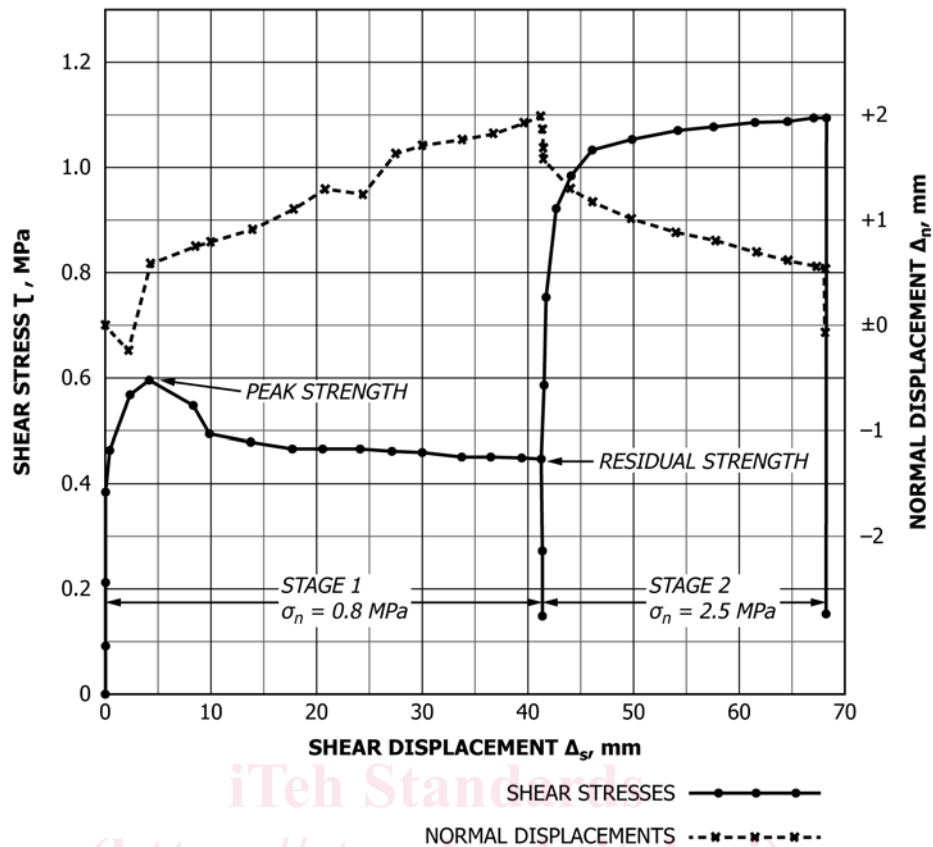

FIG. 1 Shear Stress – Displacement Graphs

4.2 The blocks are not to be disturbed during preparation operations. The base of the block coincides with the plane to be sheared.

4.3 A normal load is applied perpendicular to the shear plane and then a side load is applied to induce shear along the plane and discontinuity. A typical equipment configuration is shown in Fig. 3.

### 5. Significance and Use

5.1 Because of scale effects, there is no simple method of predicting the in situ shear strength of a rock discontinuity from the results of laboratory tests on small specimens; in situ tests on large specimens are the most reliable means.

5.2 Results can be employed in stability analysis of rock engineering problems, for example, in studies of slopes, underground openings, and dam foundations. In applying the test results, the pore water pressure conditions and the possibility of progressive failure must be assessed for the design case, as they may differ from the test conditions.

5.3 Tests on intact rock that are free from planes of weakness are usually accomplished using laboratory triaxial testing. Intact rock can, however, be tested in situ in direct shear if the rock is weak and if the specimen block encapsulation is sufficiently strong.

NOTE 1—The quality of the result produced by this standard is dependent on the competence of the personnel performing it, and the suitability of the equipment and facilities used. Agencies that meet the criteria of Practice D3740 are generally considered capable of competent

and objective testing/sampling/inspection/etc. Users of this standard are cautioned that compliance with Practice D3740 does not in itself assure reliable results. Reliable results depend on many factors; Practice D3740 provides a means of evaluating some of those factors.

### 6. Apparatus

6.1 *Equipment for Cutting and Encapsulating the Test Block*—This equipment includes rock saws, drills, hammer and chisels, formwork of appropriate dimensions and rigidity, expanded polystyrene sheeting or weak filler, and materials for reinforced concrete encapsulation.

6.2 *Equipment for Applying the Normal Load*—This equipment includes flat jacks, hydraulic rams, or dead load of sufficient capacity to apply the required normal loads as shown in Fig. 3.

NOTE 2—If a dead load is used for normal loading, precautions are required to ensure accurate centering and stability. If two or more hydraulic rams are used for loading, care is needed to make sure their operating characteristics are identically matched and they are in exact parallel alignment.

6.2.1 Each hydraulic ram should be provided with a spherical seat. The travel of rams, and particularly of flat jacks, should be sufficient to accommodate the full-anticipated specimen displacement. The normal displacement may be estimated from the content and thickness of the filling and roughness of the shear surfaces. The upper limits would be the filling thickness.

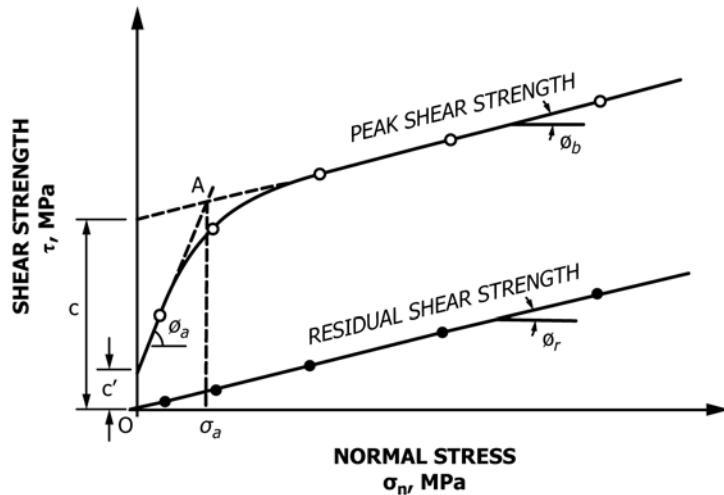

NOTE 1—In this case, intercept  $c_r$  on shear axis is zero.

- $\phi_r$  = residual friction angle,
- $\phi_a$  = apparent friction angle below stress  $\sigma_a$ ; point A is a break in the peak shear strength curve resulting from the shearing off of major irregularities on the shear surface. Between points O and A,  $\phi_a$  will vary somewhat; measure at stress level of interest. Note also that  $\phi_a = \phi_u + i$  where:
- $\phi_u$  = friction angle obtained for smooth surfaces of rock on rock, and
- $i$  = inclination angle of surface asperities.
- $\phi_b$  = apparent friction angle above stress level  $\sigma_a$  (Point A); note that  $\phi_a$  will usually be equal to or slightly greater than  $\phi_r$  and will vary somewhat with stress level; measure at the stress level of interest,  $r$ .
- $c'$  = cohesion intercept of peak shear strength curve; it may be zero.
- $c$  = apparent cohesion at a stress level corresponding to  $\phi_b$ , and
- $c_r$  = cohesion intercept of residual shear strength which is usually negligible.

FIG. 2 Shear Strength – Effective Normal Stress Graph

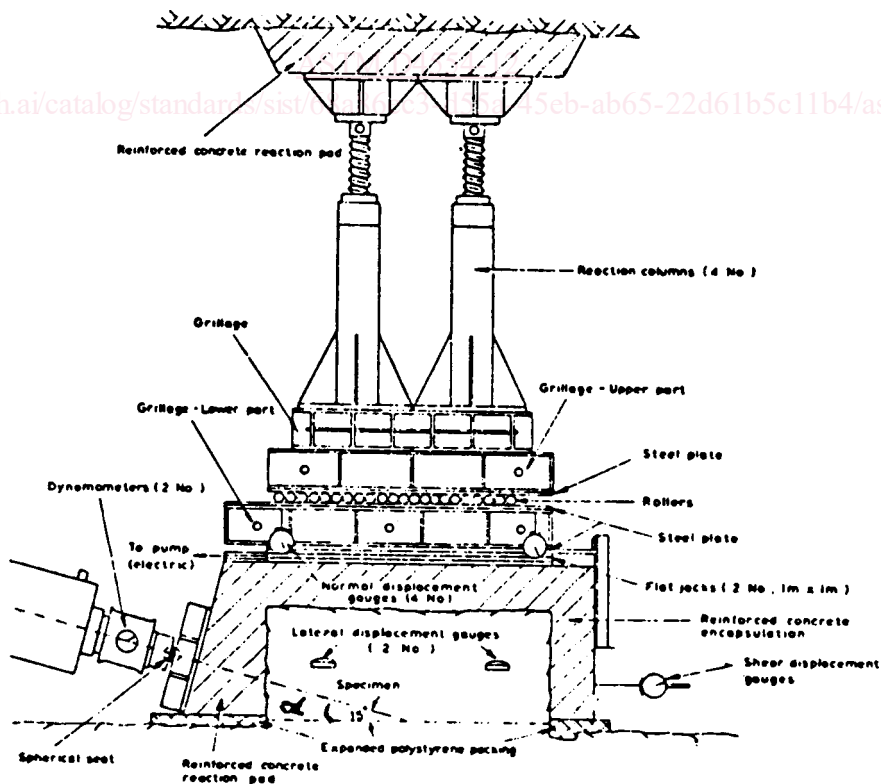

FIG. 3 Typical Arrangement of Equipment for In Situ Direct Shear Test

6.2.2 *Hydraulic System*—A hydraulic system, if used, should be capable of maintaining a normal load to within 2 % of a selected value throughout the test.

6.2.3 *Reaction System*—A reaction system to transfer normal loads uniformly to the test block includes rollers or a similar low friction device to make sure that at any given normal load, the resistance to shear displacement is less than 1 % of the maximum shear force applied in the test. Rock anchors, wire ties, and turnbuckles are usually required to install and secure the equipment.

6.3 *Equipment for Applying the Shear Force*—Hydraulic rams of adequate total capacity with at least 150 mm of travel.

6.3.1 *Hydraulic Pump*—Capable of pressurizing the shear force system.

6.3.2 *Reaction System*—A reaction system to transmit the shear force to the test block. The shear force should be uniformly distributed along one face of the specimen. The resultant line of applied shear forces should pass through the center of the base of the shear plane at an angle approximately 15° to the shear plane with an angular tolerance of  $\pm 5^\circ$ . The exact angle should be measured to  $\pm 1^\circ$ .

NOTE 3—Tests where both shear and normal forces are provided by a single set of jacks inclined at greater angles to the shear plane are not recommended, as it is then impractical to control shear and normal stresses independently.

6.4 *Equipment for Measuring the Applied Force*—This equipment includes one system for measuring normal force and another for measuring applied shearing force with an accuracy better than  $\pm 2\%$  of the maximum forces reached in the test. Load cells, dynamometers or flat jack pressure measurements may be used. Recent calibration data applicable to the range of testing should be appended to the test report. If possible, the gauges should be calibrated both before and after testing.

6.5 *Equipment for Measuring Shear, Normal, and Lateral Displacement*—Displacement should be measured, for example, using micrometer dial gauges, at eight locations on the specimen block or encapsulating material, as shown in Fig. 4 (Note 4). The shear displacement measuring system should have a travel of at least 100 mm and accuracy better than 0.1 mm. The normal and lateral displacement measuring systems should have a travel of at least 20 mm and an accuracy better than 0.05 mm. The measuring reference system (beams, anchors, and clamps) should, when assembled, be sufficiently

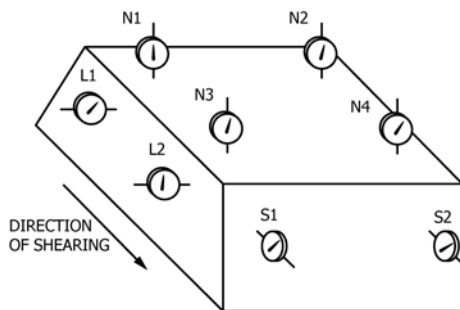

NOTE 1—Gauges S1 and S2 are for shear displacement, L1 and L2 for lateral displacement, N1 through N4 for normal displacement.

FIG. 4 Arrangement of Displacement Gauges

rigid to meet these requirements. Resetting of gauges during the test should be avoided, if possible.

NOTE 4—The surface of encapsulating material is usually insufficiently smooth and flat to provide adequate reference for displacement gauges; glass plates may be cemented to the specimen block for this purpose. These plates should be of adequate size to accommodate movement of the specimen. Alternatively, a temperature calibrated tensioned wire and pulley system with gauges remote from the specimen may be used. The system, as a whole, must be reliable and must conform to the specified accuracy requirements. Particular care is needed in this respect when employing electric transducers or automatic recording equipment.

## 7. Preparation of Test Specimens

7.1 Outline a test block such that the base of the block coincides with the plane to be sheared. The direction of shearing should correspond, if possible, to the direction of anticipated shearing in the full-scale structure to be analyzed using the test results. To inhibit relaxation, swelling, and to prevent premature sliding, it is necessary to apply a normal load to the upper face of the test specimen as soon as possible after excavation of the opening and prior to sawing the sides. Screw props or a system of rock bolts and crossbeams, may, for example, provide the load approximately equal to the overburden pressure. Maintain the load until the test equipment is in position. Saw the test block to the required dimensions, approximately 700 mm by 700 mm by 350 mm using methods that avoid disturbance or loosening of the block. See Note 5. Saw a channel approximately 20 mm deep by 80 mm wide around the base of the block to allow freedom of displacements during testing and also to facilitate possible required saturation. The block and particularly the shear plane should, unless otherwise specified, be retained as close as possible to its natural in situ conditions during preparation and testing.

NOTE 5—A test block size of 700 by 700 by 350 mm is suggested as standard for in situ testing. Smaller blocks are permissible, if, for example, the surface to be tested is relatively smooth; larger blocks may be needed when testing very irregular surfaces. For convenience, the size and shape of the test block may be adjusted so that the faces of the block coincide with joints or fissures. This adjustment minimizes block disturbance during preparation. Irregularities that would limit the thickness or emplacement of encapsulation material or reinforcement should be removed.

7.1.1 Apply a layer of weak material, such as foamed polystyrene at least 20 mm thick around the base of the test block, and then encapsulate the remainder of the block in concrete or similar material of sufficient strength and rigidity to prevent collapse or significant distortion during testing. Design the encapsulation formwork to make sure the load bearing faces are flat to a tolerance of  $\pm 3$  mm and at the correct inclination to the shear plane to a tolerance of  $\pm 2^\circ$ .

7.1.2 Carefully position and align reaction pads, anchors, and alike if required, to carry the thrust from normal and shear load systems to adjacent sound rock. Allow all concrete time to gain adequate strength prior to testing.

## 8. Calibration/Verification

8.1 Equipment used to measure the normal and shear forces shall be calibrated at least annually and verified before and after testing.

8.2 Equipment used to measure displacement shall be verified annually.