



Designation: G187 – 12

Standard Test Method for Measurement of Soil Resistivity Using the Two-Electrode Soil Box Method¹

This standard is issued under the fixed designation G187; the number immediately following the designation indicates the year of original adoption or, in the case of revision, the year of last revision. A number in parentheses indicates the year of last reapproval. A superscript epsilon (ϵ) indicates an editorial change since the last revision or reapproval.

1. Scope

1.1 This test method covers the equipment and procedures for the measurement of soil resistivity, for samples removed from the ground, for use in the assessment and control of corrosion of buried structures.

1.2 Procedures allow for this test method to be used in the field or in the laboratory.

1.3 The test method procedures are for the resistivity measurement of soil samples in the saturated condition and in the as-received condition.

1.4 The values stated in SI units are to be regarded as the standard. The values given in parentheses are for information only. Soil resistivity values are reported in ohm-centimeter.

1.5 *This standard does not purport to address all of the safety concerns, if any, associated with its use. It is the responsibility of the user of this standard to establish appropriate safety and health practices and to determine the applicability of regulatory limitations prior to use.*

2. Referenced Documents

- 2.1 *ASTM Standards*:²
- D1193 Specification for Reagent Water
 - E691 Practice for Conducting an Interlaboratory Study to Determine the Precision of a Test Method
 - G57 Test Method for Field Measurement of Soil Resistivity Using the Wenner Four-Electrode Method
 - G193 Terminology and Acronyms Relating to Corrosion

3. Terminology

3.1 Definitions:

¹ This test method is under the jurisdiction of ASTM Committee G01 on Corrosion of Metals and is the direct responsibility of Subcommittee G01.10 on Corrosion in Soils.

Current edition approved May 1, 2012. Published November 2012. Originally approved in 2005. Last previous edition approved in 2005 as G187-05. DOI: 10.1520/G0187-12.

² For referenced ASTM standards, visit the ASTM website, www.astm.org, or contact ASTM Customer Service at service@astm.org. For *Annual Book of ASTM Standards* volume information, refer to the standard's Document Summary page on the ASTM website.

3.1.1 *Ohm's law, n*—The relationship between the electromotive force, the current, and the resistance. Mathematically: current = electromotive force/resistance or $I = E/R$; where "I" is measured in amperes, "E" in volts, and "R" in ohms.

3.1.2 *resistivity (soil), n*—The electrical resistance between opposite faces of a unit cube of material; the reciprocal of conductivity.

3.1.3 *saturated soil, n*—soil whose entire soil porosity is filled with water.

3.1.4 *soil box factor, n*—A factor which is determined by a two-electrode soil box's internal dimensions (cross sectional area/distance between electrode plates). The soil box factor is multiplied by the measured resistance of a substance in the soil box to obtain that substance's resistivity.

3.1.5 *soil resistance meter, n*—An instrument capable of measuring soil resistance.

3.1.6 *two-electrode soil box, n*—A non-conductive container of known internal dimensions with two end plate electrodes for measuring a substance's resistivity.

3.2 The terminology used herein, if not specifically defined otherwise, shall be in accordance with Terminology G193. Definitions provided herein and not given in Terminology G193 are limited only to this standard.

4. Summary of Test Method

4.1 The two-electrode soil box method is predicated on measuring the resistance between two opposite faces of a box containing a substance or solution. That resistance measurement through the substance being tested is then converted to resistivity based on the conversion formula of Eq 1.

4.2 A voltage is applied to the opposing electrodes and the resulting current is measured. Ohm's law reveals the resistance. The resistivity, ρ , is then:

$$\rho \text{ (ohm-cm)} = AR/d \quad (1)$$

where:

- A = exposed area of one electrode face, cm^2 ,
- R = resistance, ohms, and

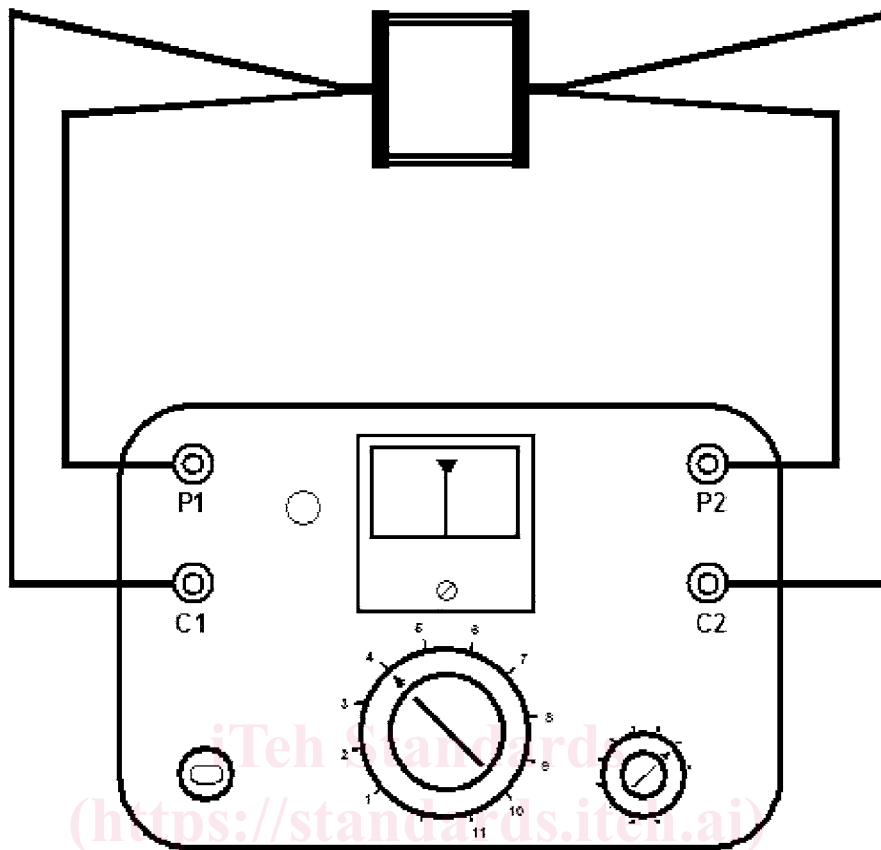

FIG. 1 Typical Connections for Use of Soil Box with Soil Resistance Meter

d = distance between electrodes, cm.

5. Significance and Use³

5.1 The resistivity of the surrounding soil environment is a factor in the corrosion of underground structures. High resistivity soils are generally not as corrosive as low resistivity soils. The resistivity of the soil is one of many factors that influence the service life of a buried structure. Soil resistivity may affect the material selection and the location of a structure.⁴

5.2 Soil resistivity is of particular importance and interest in the corrosion process because it is basic in the analysis of corrosion problems and the design of corrective measures.

5.3 The test method is focused to provide an accurate, expeditious measurement of soil resistivity to assist in the determination of a soil's corrosive nature. Test Method G57 emphasizes an *in situ* measurement commonly utilized in the design of a buried structures' corrosion control (cathodic

protection systems' ground bed design, and so forth). The two-electrode soil box method often compliments the four-pin, *in situ* soil resistivity method.

5.4 The saturated soil resistivity determined by this test method does not necessarily indicate the minimum soil resistivity.

6. Apparatus

6.1 The equipment required for the measurement of the resistivity of soil samples, either in the field or in the laboratory, consists of a two-electrode soil box, a soil resistance meter, wiring to make the necessary connections and a soil extraction tool with straightedge. A two-electrode soil box, soil resistance meter and its electrical connections are shown in Fig. 1.

6.2 *Two-Electrode Soil Box*—Two-electrode soil boxes can be constructed in various sizes provided the inside dimensions are known. Design and construction shall incorporate materials that are durable and machinable. The two end plate electrodes shall be constructed of a clean, polished corrosion-resistant metal or alloy (that is, Type 304/304L or 316/316L stainless steel) that will not form a heavy oxide film or otherwise add significant resistance. The body of the box shall be constructed of a material that is non-conductive and able to maintain its

³ Method of Test for the Resistivity of Soils Material, Texas State Department of Highways and Public Transportation – Materials and Tests Division, Test Method Tex-129-E, November 1986.

⁴ Method for Estimating the Service Life of Steel Culverts, California State Department of Transportation – Engineering Service Center, California Test 643, November 1999.

304L or 316L Electrodes

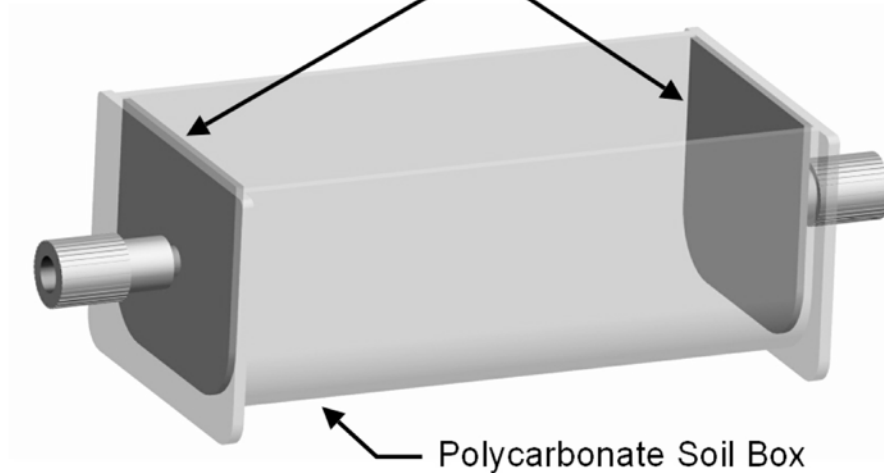

Compacted Soil Sample

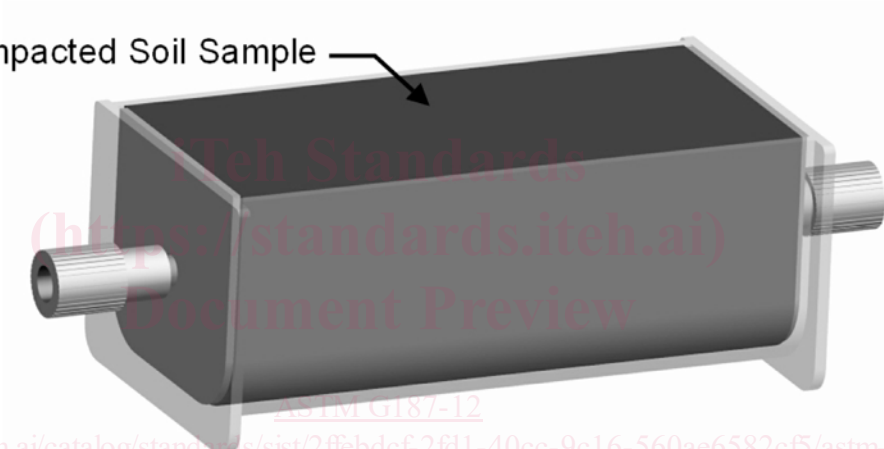

FIG. 2 Typical Two-Electrode Soil Box (Empty and Full)

desired dimensions (polycarbonate plastics). The box shall be readily cleanable to avoid contamination by previous samples. See Fig. 2.

6.3 *Soil Resistance Meter*—Commercially available soil resistance meters are commonly used for measuring soil resistivity. They offer convenience, ease of use, and repeatability. Soil resistance meters yield direct readings in ohms, which are multiplied by the appropriate factor for the specific two-electrode soil box. The meter utilized may limit the upper range of resistivity, which can be measured. In such cases, the resistivity should be reported as greater than the meter's upper limit.

6.4 *Wiring*—18 to 22 AWG insulated stranded copper wire.

NOTE 1—It is important to make reliable, low-impedance electrical connections. Ensure that all terminals are clean, and all wiring connections are made securely.

7. Reagents and Materials

7.1 Distilled or deionized water (Type IV grade as referenced in Specification D1193) to saturate samples.

8. Sampling Test Specimens, and Test Units

8.1 Collected soil samples that are to be tested in the laboratory shall be placed in an appropriate sealable container or polyethylene type bag to prevent contamination. Each sample shall be clearly marked with the location, depth, collection date, and sample temperature at the time of collection.

NOTE 2—The resistivity of a soil sample does not typically change over time. However, it is advisable to conduct your tests typically within a few weeks after sample collection to avoid any unforeseen changes. It is also advisable to avoid prolonged exposure of samples to extreme heat or direct sunlight.

8.2 Soil samples shall be representative of the area of interest. Where the stratum of interest contains a variety of soil types, it is desirable to sample each type separately.

8.3 The collected soil sample size is dependent on the volume of the soil box used. Be sure to collect enough soil to allow for compaction during the test. It is also advisable to collect extra soil in case repeated testing becomes necessary.