



Designation: F606M – 12

Standard Test Methods for Determining the Mechanical Properties of Externally and Internally Threaded Fasteners, Washers, and Rivets (Metric)¹

This standard is issued under the fixed designation F606M; the number immediately following the designation indicates the year of original adoption or, in the case of revision, the year of last revision. A number in parentheses indicates the year of last reapproval. A superscript epsilon (ϵ) indicates an editorial change since the last revision or reapproval.

This standard has been approved for use by agencies of the Department of Defense.

1. Scope*

1.1 These test methods cover establishment of procedures for conducting tests to determine the mechanical properties of metric externally and internally threaded fasteners, washers, and rivets.

1.2 Property requirements and the applicable tests for their determination are specified in individual product standards. In those instances where the testing requirements are unique or at variance with these standard procedures, the product shall specify the controlling testing requirements.

1.3 These test methods describe mechanical tests for determining the following properties:

Tests	Section
For Externally Threaded Fasteners:	3
Product Hardness	3.1
Proof Load	3.2.1
Method 1, Length Measurement	3.2.3
Method 2, Yield Strength	3.2.4
Method 3, Uniform Hardness	3.2.5
Axial Tension Testing of Full Size Products	3.4
Wedge Tension Testing of Full Size Products	3.5
Tension Testing of Machined Test Specimens	3.6
Total Extension at Fracture Test	3.7
For Internally Threaded Fasteners:	4
Product Hardness	4.1
Proof Load	4.2
Cone Proof Load Test	4.3
For Washers and Direct Tension Indicators:	5
General Requirements	5.1
Through Hardened Washers	5.2
Carburized Washers	5.3
For Rivets:	6
Product Hardness	6.1
Test for Embrittlement of Metallic Coated Externally Threaded Fasteners	7

Test Method for Determining Decarburization and Carburization	8
Test Method for Measuring Compression Loads (All Finishes) on Direct Tension Indicators Covered by Test Method F959M	Annex A1

1.4 The values stated in SI units are to be regarded as standard. No other units of measurement are included in this standard.

NOTE 1—These test methods are the metric companion of Test Methods F606.

1.5 *This standard does not purport to address all of the safety concerns, if any, associated with its use. It is the responsibility of all of the users of this standard to establish appropriate safety and health practices and determine the applicability of regulatory limitations prior to use.*

2. Referenced Documents

2.1 ASTM Standards:²

- E4 Practices for Force Verification of Testing Machines
- E8M Test Methods for Tension Testing of Metallic Materials [Metric] (Withdrawn 2008)³
- E10 Test Method for Brinell Hardness of Metallic Materials
- E18 Test Methods for Rockwell Hardness of Metallic Materials
- E83 Practice for Verification and Classification of Extensometer Systems
- E92 Test Method for Vickers Hardness of Metallic Materials (Withdrawn 2010)³
- E384 Test Method for Knoop and Vickers Hardness of Materials
- F436M Specification for Hardened Steel Washers (Metric)
- F606 Test Methods for Determining the Mechanical Properties of Externally and Internally Threaded Fasteners,

¹ These test methods are under the jurisdiction of ASTM Committee F16 on Fasteners and are the direct responsibility of Subcommittee F16.01 on Test Methods.

Current edition approved July 1, 2012. Published November 2012. Originally approved in 1987. Last previous edition approved in 2011 as F606M11. DOI: 10.1520/F0606M-12.

² For referenced ASTM standards, visit the ASTM website, www.astm.org, or contact ASTM Customer Service at service@astm.org. For *Annual Book of ASTM Standards* volume information, refer to the standard's Document Summary page on the ASTM website.

³ The last approved version of this historical standard is referenced on www.astm.org.

*A Summary of Changes section appears at the end of this standard

- Washers, Direct Tension Indicators, and Rivets
- F959M Specification for Compressible-Washer-Type Direct Tension Indicators for Use With Structural Fasteners (Metric)
- F1624 Test Method for Measurement of Hydrogen Embrittlement Threshold in Steel by the Incremental Step Loading Technique
- F2328M Test Method for Determining Decarburization and Carburization in Hardened and Tempered Threaded Steel Bolts, Screws and Studs (Metric)

3. Test Methods for Externally Threaded Fasteners

3.1 *Product Hardness*—Tests shall be conducted after the removal of any surface oxide, decarburization, plating or other coating. All readings shall be within the hardness values listed in the product specification. The average of all readings on the same part shall be considered as the product hardness. Test results shall conform to the product specification for the lot represented by the test specimens to be considered conforming. Test specimen preparation and hardness tests shall be conducted in accordance with Test Method E18 for Rockwell tests, Test Method E10 for Brinell tests, Test Method E92 for Vickers tests, or Test Method E384 for Microhardness tests. The method used is at the option of the manufacturer, with regards to the size and grade of the products.

3.1.1 *Routine Test Locations*—For testing the hardness of the finished product, the following test locations can be used:

3.1.1.1 For hex and square head bolts, test shall be conducted on the wrench flats, top of head, unthreaded shank, end of bolt or at the arbitration location.

3.1.1.2 For studs, products without parallel wrench flats, and for head styles other than hex and square, tests shall be conducted on the unthreaded shank, end of the bolt or stud or at the arbitration location.

3.1.1.3 Stress-relieved products (see 3.1.1.1 and 3.1.1.2) are measured anywhere on the surface or through the cross section. Refer to the product specification for particular test location or use the arbitration location.

3.1.1.4 The Rockwell hardness scale may be used for all product diameters; however, the Brinell hardness is limited to products over 30 mm nominal diameter.

3.1.2 *Laboratory Inspection*—After observing 3.1 and 3.1.1, a minimum of three readings shall be taken on each sample of finished product.

3.1.3 *Arbitration Test Location*—For purposes of arbitration between the purchaser and seller over reported test results, hardness tests shall be conducted at the mid-radius ($r/2$) of a transverse section through the threads taken at a distance of approximately one diameter from the point end of the bolt or one end of the stud. Four readings shall be taken approximately 90° to one another on the same plane, if product size permits. Smaller diameter products may also use the opposite parallel surface area of the bolt head end as sectioned above (see Fig. 1). The use of Brinell hardness is limited to product sizes greater than 48 mm nominal diameter.

3.2 *Tension Tests*—It is preferred that fasteners and studs be tested full size, and it is customary, when so testing to specify a minimum ultimate load in kilonewtons (or stress in megapascals). Sections 3.2 through 3.5 apply when testing externally threaded fasteners full size. Section 3.6 shall apply where the individual product specifications permit the use of machined specimens (see Test Methods E8M).

3.2.1 *Proof Load*—The proof-load test consists of stressing the product with a specified load that the product must withstand without measurable permanent set. Alternatives that determine the ability of a fastener to pass the proof-load test are the yield strength test and the uniform hardness test. Any of these tests may be used, but the proof-load test (3.2.3) shall be the arbitration method in case of any dispute (see Test Methods E8M).

3.2.2 In both Methods 1 and 2, assemble the product in the fixture of the tension testing machined so that six complete threads (except for heavy hex structural bolts, which shall be based on four threads) are exposed between the grips. This is obtained by freely running the nut or fixture to the thread runout of the specimen and then unscrewing the specimen six full turns. For continuous threaded fasteners, at least six full threads shall be exposed.

3.2.3 *Test Method 1, Length Measurement*—To ensure consistent and repetitive length measurements of the fastener, the threaded end and top of the bolt head shall have conical

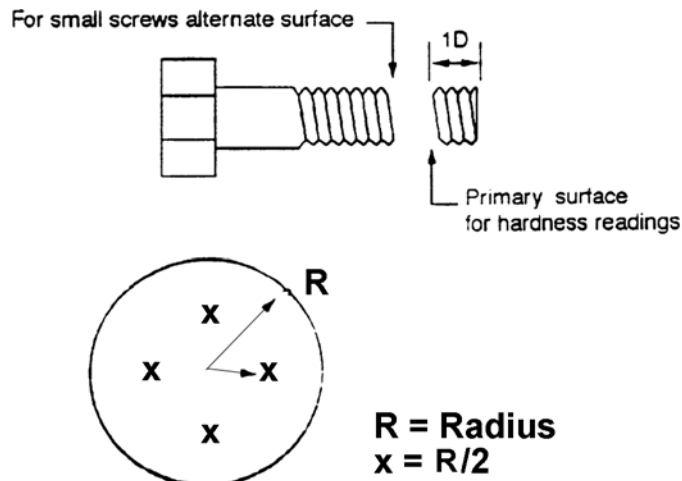

FIG. 1 Hardness Arbitration Test Location

depressions made at the approximate axis or center line of the fastener. In the event of a dispute over test results the test shall be conducted after the removal of all manufacturer or grade markings, surface oxide, decarburization, plating, other coating or a combination thereof, to achieve a clean, flat surface and the conical depressions shall be created using a lathe or some type of centering fixture. Care shall be taken to clean all debris from the conical depressions before measuring the part. When fasteners are too long to test in the available equipment they may be cut to 200 mm ± 3 mm and tested using Method 1. If there is a dispute over results when testing the same part or lot of parts both full size and cut to 200 mm the 200 mm test results shall determine acceptance. The measuring instrument shall have pointed anvils that mate with the center line depressions and be capable of measuring changes in length of 0.0025 mm with an accuracy of 0.0025 mm in any 0.025 mm range. Place the fastener between the measuring anvils. The fastener shall be rotated at least 360 degrees to assure sound seating. At the position where the lowest value is indicated the instrument shall be zeroed or the indicated measurement shall be recorded. If using a bolt extensometer, the bolt with attached extensometer may be assembled into the tension testing machine. If not, mark the fastener so it may be placed as close as possible to the same position for the second reading. Remove and assemble the fastener into the tension testing machine as outlined in 3.4. With a test speed which shall not exceed 3 mm/min, as determined with a free-running cross head, axially load the fastener to the proof load value specified in the product specification. This load shall be maintained for a period of 10 s before releasing the load. Replace the fastener between the measuring anvils and rotate at least 360 degrees as before. The fastener shall be stopped at the position where the lowest value is indicated. The measurement shall show no permanent elongation. A tolerance of ±0.013 mm shall be allowed (for measurement error only) between the measurement made before loading and that made after loading. Variables such as straightness, thread alignment, or measurement error could

result in apparent elongation of the product when the specified proof load is initially applied. In such cases, the product may be retested using a 3 % greater load, and shall be considered acceptable if there is no difference in the length measurement after this loading within a 0.013-mm measurement tolerance as outlined.

3.2.3.1 *Proof Load-Speed and Time of Loading*—When using Method 1, the speed of testing, as determined with a free-running cross head, shall not exceed 3 mm/min, and the proof load shall be maintained for a period of 10 s before releasing the load.

3.2.4 *Method 2, Yield Strength*—Assemble the product in the testing equipment as outlined in 3.4. As the load is applied, measure and record the total elongation of the product or any part of it that includes the exposed threads to produce a load-elongation diagram. Determine the load or stress at an offset equal to 0.2 % of the length of fastener occupied by six full threads as shown in Fig. 2, (except for heavy hex structural bolts, which shall be based on four threads) by the method described in 3.6.3.1.

3.2.4.1 *Method 2A, Yield Strength for Austenitic Stainless Steel and Nonferrous Materials*—Assemble the product in the testing equipment as outlined in 3.4. As the load is applied, measure and record the total elongation of the product in order to produce a load elongation diagram. Determine the load or stress at an offset equal to 0.2 % strain, based on the length of the bolt between the holders as shown in Fig. 2, which will be subject to elongation under load, by using the method described in 3.6.3.1.

3.2.5 *Method 3, Uniform Hardness*—The fasteners shall be tested for hardness as described in 3.1, and in addition, the hardness shall also be determined in the core. The difference between the mid-radius and core hardness shall be not more than three points on a Rockwell C Scale; and both readings must be within product specification.

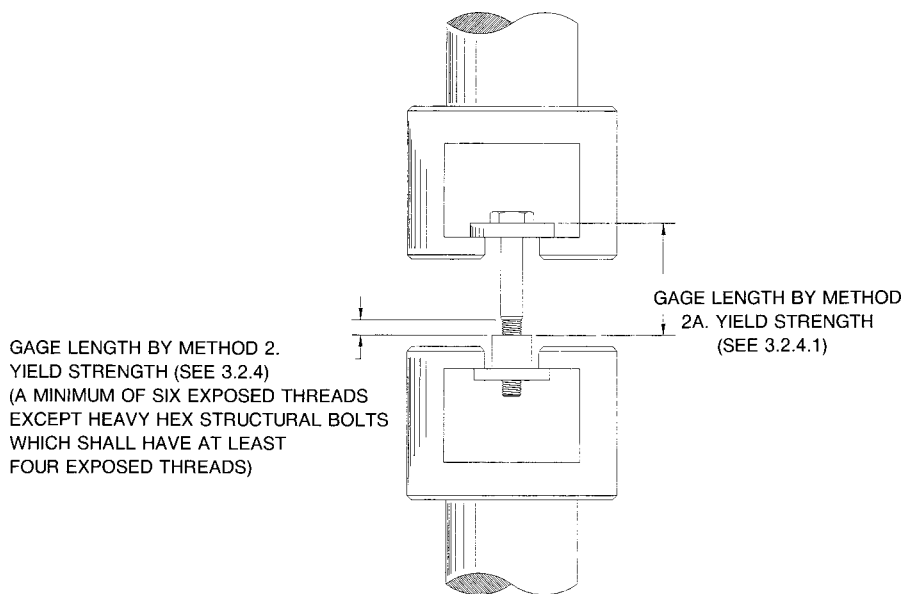

FIG. 2 Tension Testing of Full-Size Fastener (Typical Set-Up)

NOTE 2—This test is valid for fasteners up to and including 25 mm in diameter.

3.3 *Fasteners and Studs Too Short for Tension Testing*—Product lengths less than those shown in Table 1 for product 5 through 20 mm in diameter and less than 3 diameters in length for product greater than 20 mm in diameter, or that do not have sufficient threads for proper engagement, and still leave the specified number of complete threads exposed between the grips, shall be deemed too short for tension testing, and acceptance shall be based on a hardness test performed in accordance with 3.1. If tests other than product hardness are required, their requirements should be referenced in the product specification.

3.4 *Axial Tension Testing of Full Size Products:*

3.4.1 Test fasteners in a holder with a load axially applied between the head and a nut or suitable fixture (see Fig. 2), either of which shall have sufficient thread engagement to develop the full strength of the product. Assemble the nut or fixture on the product, leaving six complete fastener threads exposed between the grips (except for heavy hex structural fastener, which shall have four threads exposed between grips).

3.4.2 Test studs by assembling one end of the threaded fixture to the thread runout. For studs having unlike threads, this shall be the end which has the finer pitch thread, or with the larger minor diameter. Likewise, assemble the other end of the stud in the threaded fixture, leaving six complete threads exposed between the grips. For continuous studs, at least six complete threads shall be exposed between the fixture ends. The maximum speed of the free running cross head shall not exceed 25 mm/min. When reporting the tensile strength of the product, calculate the thread stress area as follows:

$$A_s = 0.7854 (D - 0.9382P)^2 \quad (1)$$

where:

- A_s = thread stress area, mm²,
- D = nominal diameter of the fasteners or stud, mm, and
- P = thread pitch, mm.

3.4.3 To meet the requirements of the test described in 3.4.1 and 3.4.2, the product shall support a load prior to fracture not less than the minimum tensile strength specified in the product specification for its size, property class, and thread series. In addition, fracture shall occur in the body or the threaded section with no fracture at the juncture of the body and head. When tensile testing externally threaded fasteners made of austenitic stainless steel and the test fastener’s thread pulls out

of the internally threaded test fixture after the minimum tensile strength requirement has been reached, the fasteners shall be considered conforming to the tensile strength requirement.

3.5 *Wedge Tension Testing of Full-Size Product*—The wedge tensile strength of a hex or square-head fastener, socket-head cap screw, (with the exception of socket button or flat countersunk head products) or stud is the tensile load that the product is capable of sustaining when stressed with a wedge under the head. The purpose of this test is to obtain the tensile strength and demonstrate the “head quality” and ductility of the product.

3.5.1 *Wedge Tension Testing of Fasteners*— Determine the ultimate load of the fastener as described in 3.4 except place a wedge under the fastener head. When both wedge and proof load testing are required by the product specification use the proof load-tested fastener for wedge testing. The wedge shall have a minimum hardness of 45 HRC. Additionally, the wedge shall have a minimum thickness of one half the nominal fastener diameter (measure at the thin side of the hole, Fig. 3). The wedge shall have an included angle as shown in Table 2 for the product type being tested. The hole in the wedge shall have a clearance over the nominal size of the fastener, and its edges top and bottom shall be rounded as specified in Table 3. The minimum outside dimension of the wedge shall be such that during the test no corner loading of the product head (adjacent to the wedge) shall occur. (See head orientation in Fig. 3). The bolt shall be tension tested to fracture. The fastener shall be tension tested to fracture. To meet the requirements of this test, the fastener shall support a load prior to fracture not less than the minimum tensile strength specified in the product specification for the applicable size, property class, and thread series. In addition, the fracture shall occur in the body or threaded portion with no fracture at the junction of head and shank. When tensile testing externally threaded fasteners made of austenitic stainless steel and the test fastener’s thread pulls out of the internally threaded test fixture after the minimum tensile strength requirement has been reached, the fasteners shall be considered conforming to the tensile strength requirement.

NOTE 3—Fracture at the junction of the head and shank is prohibited at any load, including those above the minimum requirements.

3.5.2 *Wedge Tension Testing of Studs*— When both wedge tension and proof load testing are required by the product specification, assemble one end of the same stud previously used for proof load testing in a threaded fixture to the thread runout. For studs having unlike threads, this shall be the end with the finer pitch thread or with the larger minor diameter. Assemble the other end of the stud in a threaded wedge to the runout and then unscrew six full turns, leaving six complete threads exposed between the grips (see Fig. 4). For continuous threaded studs, at least six full threads shall be exposed between the fixture ends. The angle of the wedge for the stud size and property class shall be as specified in Table 2. Assemble the stud in the testing machine and tension test to fracture, as described in 3.4. The minimum hardness of the threaded wedge shall be 45 HRC. The length of the threaded section of the wedge shall be equal to at least the diameter of the stud. To facilitate removal of the broken stud, counterbore

TABLE 1 Minimum Length of Product Requiring Tension Testing

Nominal Product Diameter, mm	Minimum Length, mm
5	12
6	14
8	20
10	25
12	30
14	35
16	40
20	45
Over 20	3D ^A

^A The D equals the nominal diameter of the product.

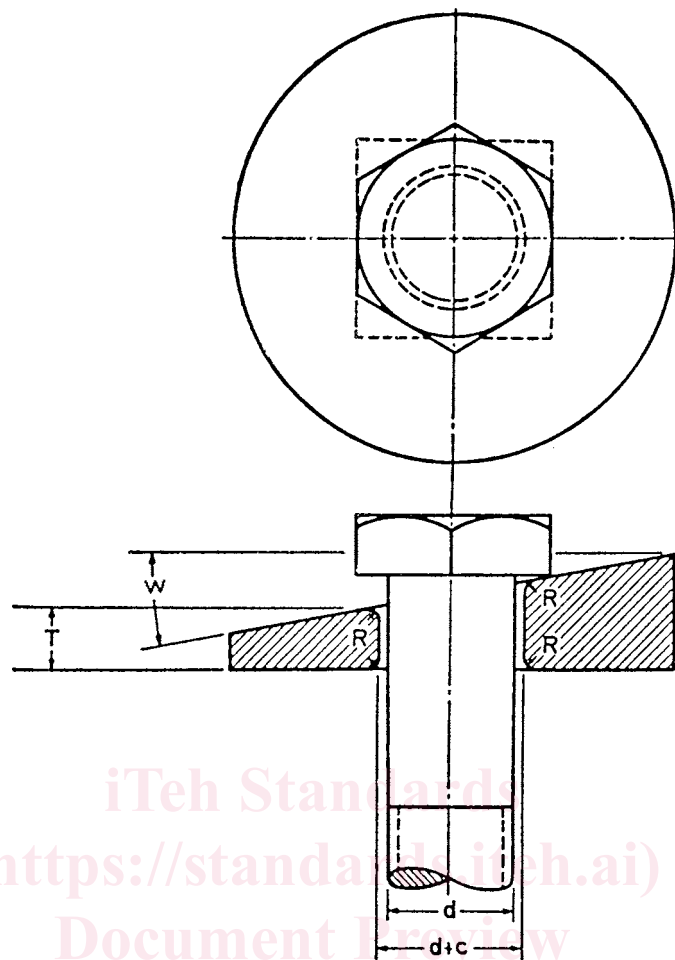

C = clearance of hole (Table 3),
 D = diameter of fastener,
 R = radius of chamfer (Table 3)
 T = reference thickness of wedge at thin side of hole, equals one half diameter of fastener, and
 W = wedge angle (Table 2).

FIG. 3 Wedge Test Details—Fasteners

TABLE 2 Tension Test Wedge Angles

NOTE 1—For use with hardened and tempered steel and alloy steel standard products. For non-ferrous and special products, see the related product specification.

Nominal Product Diameter, mm	Degrees	
	Fasteners ^A	Studs and Flange Fasteners
5–24	10	6
Over 24	6	4

^A Heat treated fasteners that are threaded one diameter or closer to the underside of the head, shall use a wedge angle of 6° for sizes 5 to 24 mm and 4° for sizes over 24 mm.

the wedge. The thickness of the wedge at the thin side of the hole shall equal the diameter of the stud plus the depth of the counterbore. The thread in the wedge shall have Class 4H6H tolerance, except when testing studs having an interference fit thread, in which case the wedge will have to be threaded to

TABLE 3 Tensile Test Wedge Hole Clearance—Details

Nominal Produce Diameter, mm	Nominal Clearance in Hole, mm	Nominal Radius on Corners of Hole, mm
To 6	0.50	0.70
Over 6–12	0.80	0.80
Over 12–20	1.60	1.30
Over 20–36	3.20	1.60
Over 36	3.20	3.20

provide a finger-free fit. The supporting fixture (Fig. 4), shall have a hole clearance over the nominal size of the stud, and shall have its top and bottom edges rounded or chamfered to the same limits specified for the hardened wedge in Table 3. To meet the requirements of this test, the stud shall support a load prior to fracture not less than the minimum tensile strength specified in the product specification for its size, property class, and thread series. The fracture shall occur in the threaded section or in the body if the stud does not have a continuous thread. When tensile testing externally threaded fasteners made

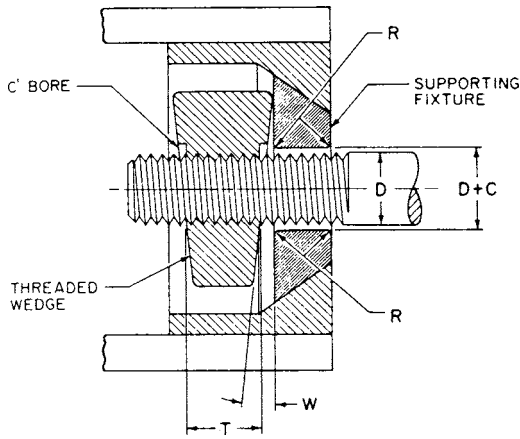

- C = clearance of hole, (see Table 3)
- D = diameter of stud
- R = radius or chamfer, (see Table 3)
- T = E plus depth of counterbore
- W = wedge angle (see Table 2)
- E = length of threaded section of wedge = D

FIG. 4 Wedge Test Details—Studs

of austenitic stainless steel and the test fastener's thread pulls out of the internally threaded test fixture after the minimum tensile strength requirement has been reached, the fasteners shall be considered conforming to the tensile strength requirement.

3.6 Tension Testing of Machined Test Specimens—Where fasteners and studs cannot be tested full size, conduct tests using test specimens machined from the fastener or stud (see Test Methods E8M).

3.6.1 Fasteners and studs shall have their shanks machined to the dimensions shown in Fig. 5. The reduction of the shank diameter of heat-treated fasteners and studs with nominal diameters larger than 16 mm shall not exceed 25 % of the

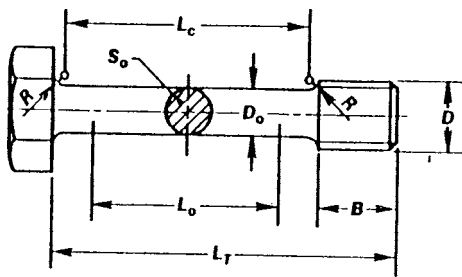

- D = nominal thread diameter,
- D_o = diameter of test piece (D_o < minor diameter of thread),
- B = length of thread (B ≥ D),
- L_o = 5D_o or,

$$(5.65\sqrt{S_o})$$

- L_c = length of straight portion (L_o + D_o),
- L_T = total length of test piece (L_c + 2R + B),
- L_u = length after fracture,
- S_o = cross-sectional area, and
- R = fillet radius (R ≥ 4 mm).

FIG. 5 Tension Test Specimen with Turned-Down Shank

original diameter of the product. Alternatively, fasteners 16 mm in diameter or larger may have their shanks machined to a test specimen with the axis of the specimen located midway between the axis and outside surface of the fastener as shown in Fig. 6. In either case, machined test specimens shall exhibit tensile strength, yield strength (or yield point), elongation, and reduction of area equal to or greater than the values of these properties specified for the product size in the applicable product specification when tested in accordance with this section.

NOTE 4—Dimensional tolerances for all test fixtures used in this test method, unless otherwise noted, shall conform to standard machining practices.

3.6.2 Determination of Tensile Properties:

3.6.2.1 Yield Point—Yield point is the first stress in a material, less than the maximum obtainable stress, at which an increase in strain occurs without an increase in stress. Yield point is intended for application only for material that may exhibit the unique characteristic of showing an increase in strain without an increase in stress. The stress-strain diagram is characterized by a sharp knee or discontinuity. Determine yield point by one of the following methods.

3.6.2.2 Drop of the Beam or Halt of the Pointer Method—In this method apply an increasing load to the specimen at a uniform rate. When a lever and poise machine is used, keep the beam in balance by running out the poise at approximately a steady rate. When the yield point of the material is reached, the increase of the load will stop, but run the poise a small amount beyond the balance position, and the beam of the machine will drop for a brief interval of time. When a machine equipped with a load-indicating dial is used, there is a halt or hesitation of the load-indicating pointer which corresponds to the drop of the beam. Record the load at the “drop of the beam” or the “halt of the pointer.” This is the yield point of the fastener or stud.

3.6.2.3 Autographic Diagram Method—When a sharp-kneed stress-strain diagram is obtained by an autographic device, take the stress corresponding to the top of the knee (see Fig. 7) or the stress at which the curve drops as the yield point (see Fig. 8).

3.6.2.4 Total Extension Under Load—When testing material for yield point and the test specimens may not exhibit a well-defined disproportionate deformation that characterizes a

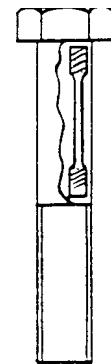

FIG. 6 Location of Standard Tension Test Specimen when Turned from Large Size Fastener