

ISO/TC 61/SC 5

Secretariat: DIN

Voting begins on:
2021-11-16

Voting terminates on:
2022-01-11

Plastics — Measurement of resistivity of conductive plastics

Plastiques — Mesurage de la résistivité des plastiques conducteurs

iTeh STANDARD PREVIEW
(standards.iteh.ai)

[ISO/FDIS 3915](https://standards.iteh.ai/catalog/standards/sist/282de763-edb0-4c5e-b0da-dca42243cc40/iso-fdis-3915)

<https://standards.iteh.ai/catalog/standards/sist/282de763-edb0-4c5e-b0da-dca42243cc40/iso-fdis-3915>

ISO/CEN PARALLEL PROCESSING

RECIPIENTS OF THIS DRAFT ARE INVITED TO SUBMIT, WITH THEIR COMMENTS, NOTIFICATION OF ANY RELEVANT PATENT RIGHTS OF WHICH THEY ARE AWARE AND TO PROVIDE SUPPORTING DOCUMENTATION.

IN ADDITION TO THEIR EVALUATION AS BEING ACCEPTABLE FOR INDUSTRIAL, TECHNOLOGICAL, COMMERCIAL AND USER PURPOSES, DRAFT INTERNATIONAL STANDARDS MAY ON OCCASION HAVE TO BE CONSIDERED IN THE LIGHT OF THEIR POTENTIAL TO BECOME STANDARDS TO WHICH REFERENCE MAY BE MADE IN NATIONAL REGULATIONS.



Reference number
ISO/FDIS 3915:2021(E)

iTeh STANDARD PREVIEW
(standards.iteh.ai)

ISO/FDIS 3915

<https://standards.iteh.ai/catalog/standards/sist/282de763-edb0-4c5e-b0da-dca42243cc40/iso-fdis-3915>



COPYRIGHT PROTECTED DOCUMENT

© ISO 2021

All rights reserved. Unless otherwise specified, or required in the context of its implementation, no part of this publication may be reproduced or utilized otherwise in any form or by any means, electronic or mechanical, including photocopying, or posting on the internet or an intranet, without prior written permission. Permission can be requested from either ISO at the address below or ISO's member body in the country of the requester.

ISO copyright office
CP 401 • Ch. de Blandonnet 8
CH-1214 Vernier, Geneva
Phone: +41 22 749 01 11
Email: copyright@iso.org
Website: www.iso.org

Published in Switzerland

Contents

	Page
Foreword.....	iv
Introduction.....	v
1 Scope.....	1
2 Normative references.....	1
3 Terms and definitions.....	1
4 Principle.....	1
5 Apparatus.....	1
6 Specimen.....	3
7 Number of specimens.....	4
8 Procedure.....	4
9 Expression of results.....	4
10 Test report.....	5
Bibliography.....	6

iTeh STANDARD PREVIEW (standards.iteh.ai)

ISO/FDIS 3915

<https://standards.iteh.ai/catalog/standards/sist/282de763-edb0-4c5e-b0da-dca42243cc40/iso-fdis-3915>

Foreword

ISO (the International Organization for Standardization) is a worldwide federation of national standards bodies (ISO member bodies). The work of preparing International Standards is normally carried out through ISO technical committees. Each member body interested in a subject for which a technical committee has been established has the right to be represented on that committee. International organizations, governmental and non-governmental, in liaison with ISO, also take part in the work. ISO collaborates closely with the International Electrotechnical Commission (IEC) on all matters of electrotechnical standardization.

The procedures used to develop this document and those intended for its further maintenance are described in the ISO/IEC Directives, Part 1. In particular, the different approval criteria needed for the different types of ISO documents should be noted. This document was drafted in accordance with the editorial rules of the ISO/IEC Directives, Part 2 (see www.iso.org/directives).

Attention is drawn to the possibility that some of the elements of this document may be the subject of patent rights. ISO shall not be held responsible for identifying any or all such patent rights. Details of any patent rights identified during the development of the document will be in the Introduction and/or on the ISO list of patent declarations received (see www.iso.org/patents).

Any trade name used in this document is information given for the convenience of users and does not constitute an endorsement.

For an explanation of the voluntary nature of standards, the meaning of ISO specific terms and expressions related to conformity assessment, as well as information about ISO's adherence to the World Trade Organization (WTO) principles in the Technical Barriers to Trade (TBT), see www.iso.org/iso/foreword.html.

This document was prepared by Technical Committee ISO/TC 61, *Plastics*, Subcommittee SC 5, *Physical-chemical properties*, in collaboration with the European Committee for Standardization (CEN) Technical Committee CEN/TC 249, *Plastics*, in accordance with the Agreement on technical cooperation between ISO and CEN (Vienna Agreement).

This second edition cancels and replaces the first edition (ISO 3915:1981), which has been technically revised.

The main changes compared to the previous edition are as follows:

- the apparatus specifications have been revised;
- the document has been editorially revised.

Any feedback or questions on this document should be directed to the user's national standards body. A complete listing of these bodies can be found at www.iso.org/members.html.

Introduction

0.1 General

The method specified in this document is technically similar to that specified for rubber in ISO 1853.

However, it differs from that method in certain details, especially those associated with the greater stiffness of the plastic samples, and in particular in the limitation on specimen width. It takes into account two problems encountered in the measurement of resistivity of conductive plastics, namely the sensitivity of these materials to their temperature-history and strain-history, and the difficulty of making adequate electrical contact with them.

The prescribed width of the specimen is mandatory for reference purposes; however, a wider strip may be used, with correspondingly wider electrodes. There is a danger in using a wide strip, if the strip is slightly twisted and at the same time somewhat non-uniform in its resistivity. It is then possible to obtain erroneous results; the potential electrode nearer to the positive current electrode can even be found to be negative with respect to the other potential electrode.

0.2 Effect of temperature changes and strain on conductive plastics

As mentioned, the resistance of these materials is sensitive to their temperature-history and strain-history. The relationships are complex and arise from the kinetic energy and structural configuration of the carbon particles in the polymer.

The resistivity may be increased by the effects of strain produced by (or subsequent to) removal from the mould, and a treatment is described for reducing specimens to a constant strain and temperature condition before measurements are carried out on them. Specimens are also cut in two perpendicular directions to assess anisotropy.

0.3 Electrode systems (see 5.3) [ISO/FDIS 3915](#)

Certain types of electrode, when applied to these polymers, have a contact resistance which can be many thousand times greater than the intrinsic resistance of the specimen. Dry contacts under light pressure or point contacts give very high resistances. However, the present test method eliminates the effects of contact resistances unless these are excessively high. (In such a case, no result, rather than a wrong one, is generally obtained.)

iTeh STANDARD PREVIEW
(standards.iteh.ai)

ISO/FDIS 3915

<https://standards.iteh.ai/catalog/standards/sist/282de763-edb0-4c5e-b0da-dca42243cc40/iso-fdis-3915>

Plastics — Measurement of resistivity of conductive plastics

1 Scope

This document specifies the requirements for the laboratory testing of the resistivity of specially prepared specimens of plastics rendered conductive by the inclusion of conductive fillers or suitable modification of the structure. The test is applicable to materials of resistivity less than $10^6 \Omega \cdot \text{cm}$ ($10^4 \Omega \cdot \text{m}$).

The result is not strictly a volume resistivity, because of surface conduction, but the effects of the latter are generally negligible.

2 Normative references

There are no normative references in this document.

3 Terms and definitions

No terms and definitions are listed in this document.

ISO and IEC maintain terminological databases for use in standardization at the following addresses:

- ISO Online browsing platform: available at <https://www.iso.org/obp>
- IEC Electropedia: available at <https://www.electropedia.org/>

4 Principle

The principle of the four-terminal method of test is mandatory and the recommended specimen size and electrode design shall be adhered to for reference purposes, but it can sometimes be necessary to test a wider strip with electrodes of a different construction.

A stable direct current of magnitude (I) is passed between electrodes at the two ends of a strip of the material under test. The voltage drop (ΔU) between two potential electrodes is measured with an electrometer. The resistance of the portion of the strip between the potential electrodes is given by $R = \Delta U/I$, and is independent of contact resistances. Thus, the resistivity can be calculated.

5 Apparatus

See [Figure 1](#) for schematic diagram of test circuit.

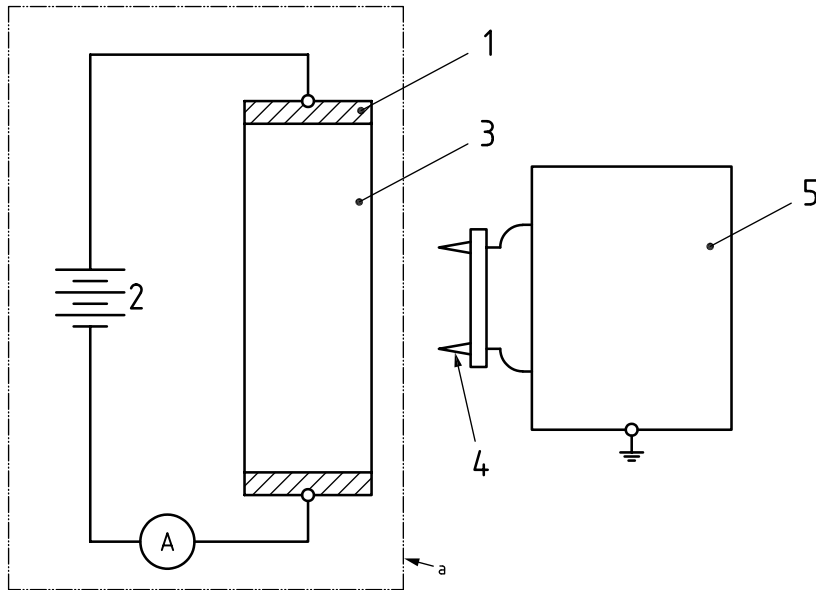

Key

- 1 current electrode
- 2 direct current source
- 3 specimen
- 4 potentiometric electrode
- 5 elektrometer
- A milli- or microammeter

^a The insulation resistance to earth of all components within this rectangle shall be greater than $10^{12} \Omega$.

iTeh STANDARD PREVIEW
(standards.iteh.ai)

ISO/FDIS 3915
<https://standards.iteh.ai/catalog/standards/sist/282de763-edb0-4c5e-b0da-dca42243cc40/iso-fdis-3915>
Figure 1 — Schematic diagram of test circuit

5.1 Current source: a source of direct current which has a minimum resistance to earth of $10^{12} \Omega$ (effected by placing it on a highly insulating sheet), and which does not cause a dissipation of power greater than 0,1 W in the specimen.

5.2 Milliammeter or microammeter, as appropriate, for measuring the current to an accuracy of $\pm 5 \%$.

NOTE Small currents can be computed from measurement of the voltage drop across a known resistance in series with the specimen, using the electrometer (5.4).

5.3 Electrodes

5.3.1 Current electrodes, of clean metal, together with either suitable clamps or grips approximately 5 mm long and extending across the full width of the specimen, or conductive paint to cover the same area.

5.3.2 Potentiometric electrode system (see Figure 2, for example), having a mass of approximately 60 g so that it exerts a force of approximately 0,6 N on the specimen. The width of the contacts shall be at least as high as the specimen width. The contacts shall normally be $(10 \pm 0,2)$ mm apart. For special purposes, the contacts may be further apart (up to 70 mm), but the separation shall be less than the

specimen length by at least 60 mm. The distance between the contacts shall be known to an accuracy of ± 2 %. The insulation resistance between the contacts shall be at least $10^{12} \Omega$.

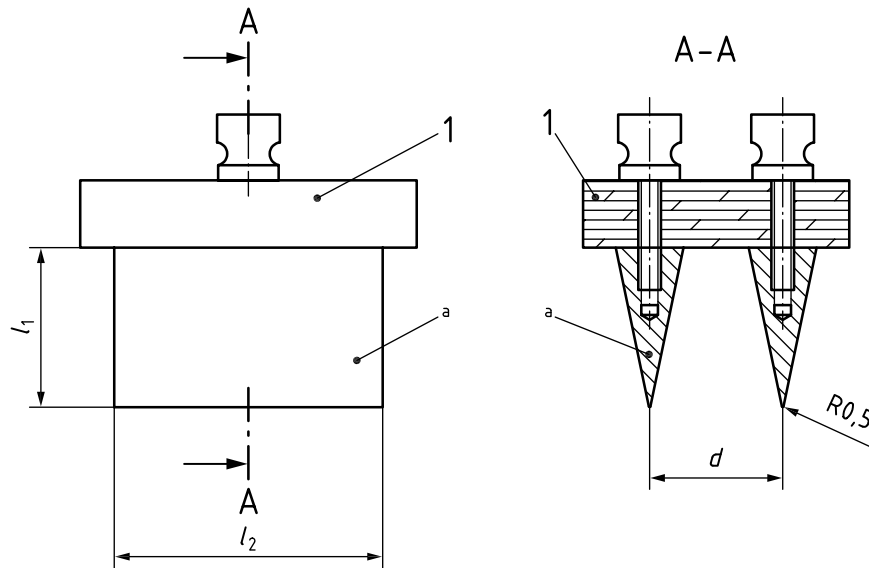

Key

l_1	height of contacts	1	polystyrene
l_2	width of contacts	a	Brass, nickel or stainless steel.
d	contact distance		R0,5 radius of potentiometric electrode tip (0,5 mm)

(standards.iteh.ai)
Figure 2 — Potentiometric electrodes

ISO/FDIS 3915

5.4 **Electrometer**, having an input resistance greater than $10^{11} \Omega$ and measuring to an accuracy of ± 5 %.

5.5 **Sheet of highly insulating material**, having a volume resistivity greater than $10^{15} \Omega \cdot \text{cm}$.

5.6 **Oven**, capable of being maintained at a temperature of $(70 \pm 2) ^\circ\text{C}$, or $(60 \pm 2) ^\circ\text{C}$, if required.

6 Specimen

The specimen shall be a strip of preferably 10 mm width. Higher widths may be used as long as they do not exceed the width of the potentiometric electrodes (see 5.3.2). The specimen shall be 70 mm to 150 mm long and shall normally be 3 mm to 4 mm thick with a tolerance on uniformity of thickness of ± 5 %. Thicker or thinner specimens may be cut from sheets or products. Care shall be taken to avoid bending or stretching the sheets or specimens, especially when they are thinner than standard.

The specimen may be cut with a knife or razor blade, but care shall be taken to minimize distortion as this can affect the resistance values.

The surfaces of the specimen shall be clean; if necessary, they may be cleaned by rubbing with fuller's earth (hydrated magnesium-aluminium silicate) and water, rinsing with distilled water and allowing to dry.¹⁾ The surfaces shall neither be buffed nor abraded, nor shall they be cleaned with organic materials that attack or swell the material.

1) A particular drying method can be stated in the material specification.

7 Number of specimens

From each of two perpendicular directions, three specimens of equal size shall be prepared and tested. The two directions should, where possible, be chosen to be along and across any direction of flow during processing.

8 Procedure

8.1 After preparation, allow the specimen to remain at room temperature and ambient humidity conditions for at least 16 h.

8.2 Prior to the commencement of the test, connect the current electrodes (5.3.1) to the ends of the specimen, either by using the clamps or grips, or by covering the same area with conductive paint.

8.3 The required conditioning of the specimen should be described in the material specification. If this is not the case, the following procedure can be useful in most cases: Immediately after applying the current electrodes, place the specimen on the sheet of highly insulating material (5.5) and heat in the oven (5.6) for 2 h at a temperature of (70 ± 2) °C to remove strains and irregularities caused by previous treatment. Cool for at least 1 h and test at (23 ± 2) °C and (50 ± 5) % relative humidity without disturbing the specimen. The specimen shall always be tested on the sheet of insulating material. With some materials, distortion can occur at 70 °C and heating for 5 h at (60 ± 2) °C can then be preferable.

8.4 Place the potentiometric electrode system (5.3.2) on the specimen, ensuring that the knife-edge contacts are at right angles to the direction of current flow and that neither potentiometric electrode is within 20 mm of a current electrode. Apply the current and measure the voltage drop between the potentiometric electrodes using the electrometer (5.4).

Repeat the measuring procedure twice more on the same specimen, moving the potentiometric electrodes each time to obtain measurements over lengths of specimen evenly distributed between the current electrodes.

8.5 Test the other five specimens similarly.

9 Expression of results

9.1 Calculate the resistance R , in ohms, corresponding to each position of the potentiometric electrodes, using [Formula \(1\)](#):

$$R = \frac{\Delta U}{I} \quad (1)$$

where

ΔU is the voltage drop, in volts, between the potentiometric electrodes;

I is the current, in amperes, through the specimen.

9.2 The resistivity ρ , expressed in ohm centimetres, is given by [Formula \(2\)](#):

$$\rho = \frac{R \times A}{d} \quad (2)$$