

FINAL
DRAFT

INTERNATIONAL
STANDARD

ISO/FDIS
11540

ISO/TC 10

Secretariat: SIS

Voting begins on:
2021-04-30

Voting terminates on:
2021-06-25

Writing and marking instruments — Specification for caps to reduce the risk of asphyxiation

*Instruments pour l'écriture et le marquage — Spécifications pour les
capuchons afin de réduire le risque d'asphyxie*

iTeh STANDARD PREVIEW
(standards.iteh.ai)

ISO/FDIS 11540

[https://standards.iteh.ai/catalog/standards/sist/64flaa14-4b60-407f841f-
b098544ae61b/iso-fdis-11540](https://standards.iteh.ai/catalog/standards/sist/64flaa14-4b60-407f841f-b098544ae61b/iso-fdis-11540)

RECIPIENTS OF THIS DRAFT ARE INVITED TO SUBMIT, WITH THEIR COMMENTS, NOTIFICATION OF ANY RELEVANT PATENT RIGHTS OF WHICH THEY ARE AWARE AND TO PROVIDE SUPPORTING DOCUMENTATION.

IN ADDITION TO THEIR EVALUATION AS BEING ACCEPTABLE FOR INDUSTRIAL, TECHNOLOGICAL, COMMERCIAL AND USER PURPOSES, DRAFT INTERNATIONAL STANDARDS MAY ON OCCASION HAVE TO BE CONSIDERED IN THE LIGHT OF THEIR POTENTIAL TO BECOME STANDARDS TO WHICH REFERENCE MAY BE MADE IN NATIONAL REGULATIONS.



Reference number
ISO/FDIS 11540:2021(E)

© ISO 2021

iTeh STANDARD PREVIEW
(standards.iteh.ai)

ISO/FDIS 11540

<https://standards.iteh.ai/catalog/standards/sist/64f1aa14-4b60-407f-841f-b098544ae61b/iso-fdis-11540>



COPYRIGHT PROTECTED DOCUMENT

© ISO 2021

All rights reserved. Unless otherwise specified, or required in the context of its implementation, no part of this publication may be reproduced or utilized otherwise in any form or by any means, electronic or mechanical, including photocopying, or posting on the internet or an intranet, without prior written permission. Permission can be requested from either ISO at the address below or ISO's member body in the country of the requester.

ISO copyright office
CP 401 • Ch. de Blandonnet 8
CH-1214 Vernier, Geneva
Phone: +41 22 749 01 11
Email: copyright@iso.org
Website: www.iso.org

Published in Switzerland

Contents

	Page
Foreword	iv
Introduction	v
1 Scope	1
2 Normative references	1
3 Terms and definitions	1
4 Requirements	1
4.1 General.....	1
4.2 Cap size.....	1
4.3 Ventilated caps air flow.....	2
4.4 Test report.....	2
5 Identification	3
Annex A (normative) Test for air flow	4
Annex B (informative) Design guidance for pen caps vent area	6
Bibliography	7

iTeh STANDARD PREVIEW (standards.iteh.ai)

[ISO/FDIS 11540](https://standards.iteh.ai/catalog/standards/sist/64flaa14-4b60-407f-841f-b098544ae61b/iso-fdis-11540)

<https://standards.iteh.ai/catalog/standards/sist/64flaa14-4b60-407f-841f-b098544ae61b/iso-fdis-11540>

Foreword

ISO (the International Organization for Standardization) is a worldwide federation of national standards bodies (ISO member bodies). The work of preparing International Standards is normally carried out through ISO technical committees. Each member body interested in a subject for which a technical committee has been established has the right to be represented on that committee. International organizations, governmental and non-governmental, in liaison with ISO, also take part in the work. ISO collaborates closely with the International Electrotechnical Commission (IEC) on all matters of electrotechnical standardization.

The procedures used to develop this document and those intended for its further maintenance are described in the ISO/IEC Directives, Part 1. In particular, the different approval criteria needed for the different types of ISO documents should be noted. This document was drafted in accordance with the editorial rules of the ISO/IEC Directives, Part 2 (see www.iso.org/directives).

Attention is drawn to the possibility that some of the elements of this document may be the subject of patent rights. ISO shall not be held responsible for identifying any or all such patent rights. Details of any patent rights identified during the development of the document will be in the Introduction and/or on the ISO list of patent declarations received (see www.iso.org/patents).

Any trade name used in this document is information given for the convenience of users and does not constitute an endorsement.

For an explanation of the voluntary nature of standards, the meaning of ISO specific terms and expressions related to conformity assessment, as well as information about ISO's adherence to the World Trade Organization (WTO) principles in the Technical Barriers to Trade (TBT), see www.iso.org/iso/foreword.html.

This document was prepared by Technical Committee ISO/TC 10, *Technical product documentation*.

This third edition cancels and replaces the second (ISO 11540:2014), of which it constitutes a minor revision. The changes to the previous edition are as follows:

- [Clause 2](#), Normative references, has been introduced and the clause numbering changed accordingly;
- In [A.3.2](#) the reference to [A.3.3](#) has been corrected to [A.3.1](#);
- NOTE 1 and NOTE 2 have been deleted from [Figure B.1](#);
- minor editorial changes.

Any feedback or questions on this document should be directed to the user's national standards body. A complete listing of these bodies can be found at www.iso.org/members.html.

Introduction

If a child inhales a pen cap it might become lodged below the larynx and block the trachea. The risk of asphyxiation can be reduced if the pen cap is ventilated or too large to enter the airway. Children must be actively discouraged from sucking, chewing or putting pen caps in their mouths. A way of avoiding the risk of inhalation of caps of writing and marking instruments is to manufacture products without caps whenever possible. However, if caps are essential, the provisions of this document minimize risk by specifying the design and performance of ventilated caps, which reduce the likelihood of inhalation and delay asphyxiation pending medical intervention.

ISO/TC 10 recognizes that while it is possible to identify the age range of the children who are most at risk, it is not possible to identify with certainty any writing instruments with detachable caps that would never be accessible to children and hence never pose a risk. It is, however, acknowledged that certain products (i.e. writing and marking instruments which are designed or only intended for use by adults, e.g. jewellery pens, expensive fountain pens, professional technical pens) are not intended for use by children and such items must be clearly labelled to that effect.

iTeh STANDARD PREVIEW (standards.iteh.ai)

[ISO/FDIS 11540](https://standards.iteh.ai/catalog/standards/sist/64f1aa14-4b60-407f-841f-b098544ae61b/iso-fdis-11540)

<https://standards.iteh.ai/catalog/standards/sist/64f1aa14-4b60-407f-841f-b098544ae61b/iso-fdis-11540>

iTeh STANDARD PREVIEW
(standards.iteh.ai)

ISO/FDIS 11540

<https://standards.iteh.ai/catalog/standards/sist/64flaa14-4b60-407f841f-b098544ae61b/iso-fdis-11540>

Writing and marking instruments — Specification for caps to reduce the risk of asphyxiation

1 Scope

This document specifies requirements to reduce the risk of asphyxiation from caps for writing and marking instruments. It relates to such instruments which in normal or foreseeable circumstances are likely to be used by children up to the age of 14 years.

This document is not applicable to the following:

- writing and marking instruments which are designed or only intended for use by adults, e.g. jewellery pens, expensive fountain pens, professional technical pens;
- transit caps for refills.

2 Normative references

There are no normative references in this document.

3 Terms and definitions

For the purposes of this document, the following terms and definitions apply.

ISO and IEC maintain terminological databases for use in standardization at the following addresses:

- ISO Online browsing platform: available at <https://www.iso.org/obp>
- IEC Electropedia: available at <http://www.electropedia.org/>

3.1

writing and marking instruments

instruments for writing or marking with a detachable cap, including pens with a self-contained reservoir of ink or other marking fluid

3.2

cap

detachable closure designed to cover the writing or marking tip when not in use

4 Requirements

4.1 General

Caps shall conform to at least one of the following: [4.2](#) or [4.3](#).

4.2 Cap size

When a cap is introduced with its main axis perpendicular to a $16^{+0,05}_{-0,00}$ mm diameter ring gauge of at least 19 mm thickness, and part of the cap enters the gauge, at least 5 mm of the length shall not enter under its own weight, see [Figure 1](#).

NOTE Caps which conform to this subclause are deemed to be too large to present an inhalation hazard.

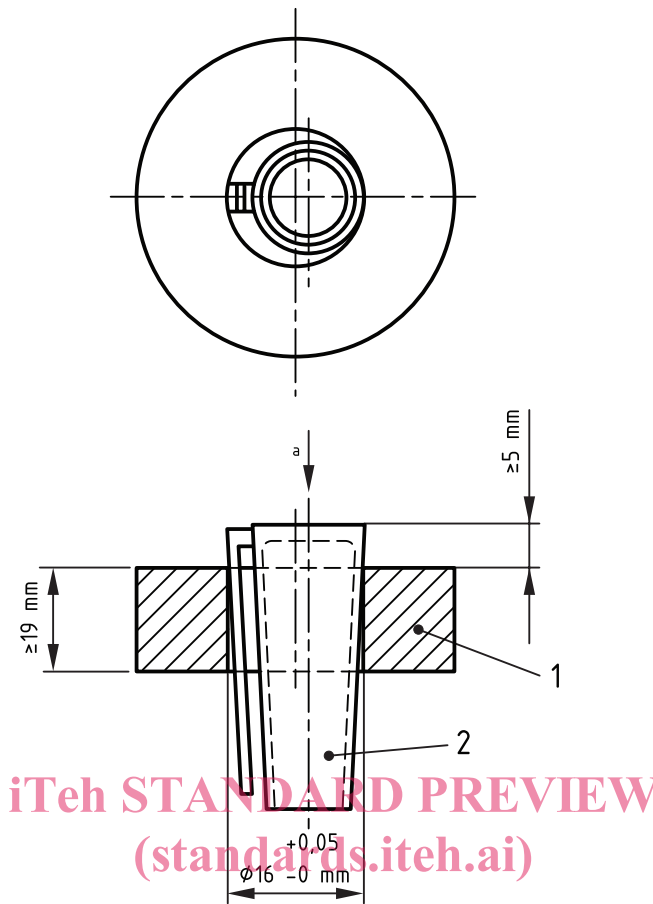

iTeh STANDARD PREVIEW
(standards.iteh.ai)

ISO/FDIS 11540

<https://standards.iteh.ai/catalog/standards/sist/64f1aa14-4b60-407f-841f-b098544ae61b/iso-fdis-11540>

Key

- 1 ring gauge
- 2 cap
- a Direction of fall.

Figure 1 — Schematic diagram of gauge

4.3 Ventilated caps air flow

When tested in accordance with [Annex A](#), caps shall permit a minimum air flow of 8 l/min, measured at room temperature, with a maximum pressure drop of 1,33 kPa.

NOTE 1 For caps relying on internal ventilation, a singular circular orifice with a cross-sectional area of approximately 3,4 mm² can be expected to satisfy this criterion, but multiple small orifices might require a larger total cross-sectional area.

NOTE 2 Guidance is given in [Annex B](#) for caps that rely on external ventilation.

NOTE 3 Caps conforming to this subclause are deemed to not present an asphyxiation hazard.

4.4 Test report

The report shall indicate whether the cap conforms to [4.2](#) or [4.3](#).

The test report should indicate at least the following information:

- a) the size of the tubing used (see [A.2.6](#)) and its percentage relationship to the circumscribing circle of the caps tested;

- b) the number of caps tested, the airflow of each cap in both directions and the minimum air flow recorded.

5 Identification

Writing or marking instruments, or their packaging or accompanying documentation, shall be legibly and indelibly identified with the name, trademark or other means of identifying the manufacturer and/or supplier.

iTeh STANDARD PREVIEW (standards.iteh.ai)

ISO/FDIS 11540

<https://standards.iteh.ai/catalog/standards/sist/64flaa14-4b60-407f841f-b098544ae61b/iso-fdis-11540>

Annex A (normative)

Test for air flow

A.1 Principle

The test cap is fully inserted into an elastomeric tube of the appropriate diameter and the air flow through the tube and the pressure drop are measured in both directions.

A.2 Apparatus

A.2.1 Air supply, pulse free and with a flow rate of at least 25 l/min within the pressure range of 4 kPa to 50 kPa.

A.2.2 Flow regulator, capable of controlling the air flow with an accuracy of $\pm 0,1$ l/min.

A.2.3 Flow gauge, capable of measuring a flow rate of between 5 l/min and 10 l/min with an accuracy of $\pm 0,2$ l/min.

A.2.4 Pressure gauge, capable of measuring a pressure of at least 4,00 kPa to an accuracy of $\pm 0,01$ kPa.

A.2.5 Coupling and tubing, suitable for connecting the equipment described above in accordance with [Figure A.1](#).

A.2.6 Elastomeric tubing, with an internal diameter of 80 % to 85 % of that of the circumscribing circle of the cap to be tested, measured at its widest point; with a wall thickness of $0,75 \text{ mm} \pm 0,25 \text{ mm}$ and shore A hardness of 55 ± 10 .

NOTE 1 The apparatus is illustrated in [Figure A.1](#).

NOTE 2 Tubing of diameters appropriate to the cap body might be difficult to obtain and it might be advantageous to manufacture the tubing, as required, by a dip-moulding technique.

A.3 Procedure

A.3.1 Cut the elastomeric tubing (see [A.2.6](#)) into a length such that when the cap is inserted there is a relaxed diameter of tubing at both ends of the cap when connected in the apparatus. Apply a soap solution or other suitable low viscosity lubricant to the full internal area of the tubing. Insert the cap into approximately the centre of the tube length and ensure that, as far as practicable, the cap is parallel to the major axis of the tubing.

A.3.2 Using suitable connectors and tubing, connect the tube/cap assembly (see [A.3.1](#)) to the apparatus, in accordance with [Figure A.1](#). Turn on the air supply and adjust the flow until the pressure gauge indicates a pressure difference of 1,33 kPa. Record the flow rate indicated on the flow gauge at this pressure.

A.3.3 Turn off the air supply, remove and reverse the tube/cap assembly and repeat [A.3.2](#). Test the cap, giving the air flow results found in each direction.