



Designation: E 1479 – 99

Standard Practice for Describing and Specifying Inductively-Coupled Plasma Atomic Emission Spectrometers¹

This standard is issued under the fixed designation E 1479; the number immediately following the designation indicates the year of original adoption or, in the case of revision, the year of last revision. A number in parentheses indicates the year of last reapproval. A superscript epsilon (ϵ) indicates an editorial change since the last revision or reapproval.

1. Scope

1.1 This practice describes the components of an inductively-coupled plasma atomic emission spectrometer (ICP-AES) that are basic to its operation and to the quality of its performance. This practice identifies critical factors affecting accuracy, precision, and sensitivity. It is not the intent of this practice to specify component tolerances or performance criteria, since these are unique for each instrument. A prospective user should consult with the vendor before placing an order, to design a testing protocol to demonstrate that the instrument meets all anticipated needs.

1.2 *This standard does not purport to address all of the safety concerns, if any, associated with its use. It is the responsibility of the user of this standard to establish appropriate safety and health practices and determine the applicability of regulatory limitations prior to use.* Specific safety hazard statements are given in Section 13.

2. Referenced Documents

2.1 ASTM Standards:

- E 135 Terminology Relating to Analytical Chemistry for Metals, Ores, and Related Materials²
- E 158 Practice for Fundamental Calculations to Convert Intensities into Concentrations in Optical Emission Spectrochemical Analysis²
- E 172 Practice for Describing and Specifying the Excitation Source in Emission Spectrochemical Analysis²
- E 416 Practice for Planning and Safe Operation of a Spectrochemical Laboratory³
- E 520 Practice for Describing Photomultiplier Detectors in Emission and Absorption Spectroscopy³

3. Terminology

3.1 *Definitions*—For terminology relating to emission spectrometry, refer to Terminology E 135.

¹ This practice is under the jurisdiction of ASTM Committee E-1 on Analytical Chemistry of Metals, Ores, and Related Materials and is the direct responsibility of Subcommittee E01.20 on Fundamental Practices.

Current edition approved Sept. 10, 1999. Published February 2000. Originally published as E 1479 – 92. Last previous edition E 1479 – 92.

² *Annual Book of ASTM Standards*, Vol 03.05.

³ *Annual Book of ASTM Standards*, Vol 03.06.

4. Summary of Practice

4.1 An ICP-AES is an instrument used to determine elemental composition. It typically is comprised of several assemblies including a radio-frequency (RF) generator, an impedance matching network (where required), an induction coil, a plasma torch, a plasma ignitor system, a sample introduction system, a light gathering optic, an entrance slit and dispersing element to sample and isolate wavelengths of light emitted from the plasma, one or more devices for converting the emitted light into an electrical current or voltage, one or more analog preamplifiers, one or more analog-to-digital converter(s), and a dedicated computer with printer (see Fig. 1⁴).

4.1.1 The sample is introduced into a high-temperature (>6000 K) plasma that is formed from the ionization of the gas stream contained in the torch. The torch is inserted through metal tubing formed into a helix, which is called the load coil. Energy is applied to the load coil by means of an RF generator.

4.1.2 The term inductively-coupled refers to the fact that the physical phenomenon of induction creates a plasma by transferring energy from the load coil to the gas stream that has been momentarily preionized by a high voltage ignitor electrode that functions only during plasma ignition.

4.2 When material passes through the plasma, it is vaporized, atomized, and many elements are almost completely ionized. Free atoms and ions are excited by collision from their ground states. When the excited atoms or ions subsequently decay to a lower energy state, they emit photons, some of which pass through the entrance slit of a spectrometer. Each element emits a unique set of emission lines. Photons of a desired wavelength may be selected from the ultraviolet and visible spectra by means of a dispersing element.

4.2.1 Instruments may determine elements either simultaneously or sequentially. The output of the detector generally is directed to a preamplifier, an analog-to-digital converter, and a computer which measures and stores a value proportional to the electrical current or voltage generated by the detector(s). Using blank and known calibration solutions, a calibration curve is generated for each element of interest.

⁴ Courtesy of PerkinElmer, Inc., 761 Main Ave., Norwalk, CT 06859.

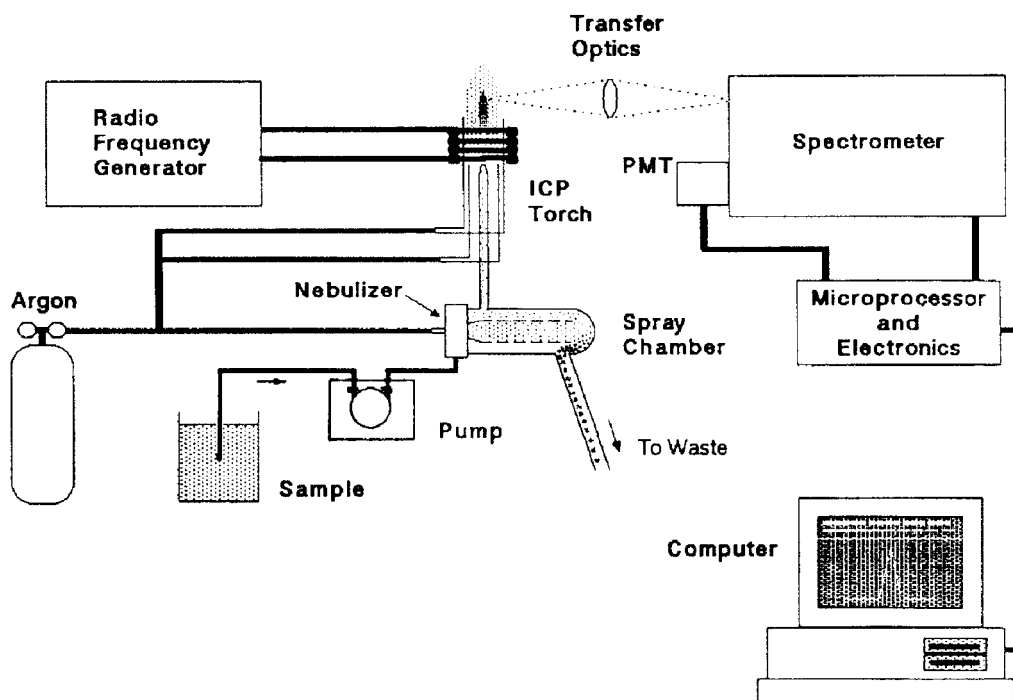

FIG. 1 Components of Inductively Coupled Plasma⁴

4.2.2 The computer compares the signals arising from the various elements in the sample to the appropriate calibration curve. The concentrations of more than 70 elements may be determined.

4.3 Sensitivities (see 12.3) in a simple aqueous solution are less than one part per million (ppm) for all of these elements, generally less than 10 parts per billion (ppb) for most, and may even be below 1 ppb for some.

4.3.1 Organic liquids may also be used as solvents yielding sensitivities that are within an order of magnitude of aqueous limits for many common organic solvents. Some organic solvents may afford detection limits similar or even superior to those obtained using aqueous solutions.

4.3.2 Direct sampling of solid materials has been performed successfully by such techniques as spark or laser ablation and slurry nebulization. However, these require greater care in the choice of reference materials and the operation of the sampling devices. Solid materials, therefore, are usually dissolved prior to analysis.

5. Significance and Use

5.1 This practice describes the essential components of an inductively-coupled plasma atomic emission spectrometer (ICP-AES). The components include excitation/radio-frequency generators, sample introduction systems, spectrometers, detectors, and signal processing and displays. This description allows the user or potential user to gain a cursory understanding of an ICP-AES system. This practice also provides a means for comparing and evaluating various systems, as well as understanding the capabilities and limitations of each instrument.

5.2 *Training*—The vendor should provide training in safety, basic theory of ICP spectrochemical analysis, operations of

hardware and software, and routine maintenance for at least one operator. Training ideally should consist of the basic operation of the instrument at the time of installation, followed by an in-depth course one or two months later. Advanced courses are also offered at several of the important spectroscopy meetings that occur throughout the year as well as by independent training institutes. Furthermore, several independent consultants are available who can provide training, in most cases at the user's site.

6. Excitation/Radio Frequency Generators

6.1 *Excitation*—A specimen is converted into an aerosol entrained in a stream of argon gas and transported through a high temperature plasma. The plasma produces excited neutral atoms and excited ions. The photons emitted when excited atoms or ions return to their ground states or lower energy levels are measured and compared to emissions from reference materials of similar composition. For further details see Practice E 172.

6.2 Radio-Frequency Generator:

6.2.1 An RF generator is used to initiate and sustain the argon plasma. Commercial generators operate at 27.12 and 40.68 MHz since these frequencies are designated as clear frequencies by U.S. Federal Communications Committee (FCC) regulations. Generators typically are capable of producing 1.0 to 2.0 kW for the 27.12 MHz generator and 1.0 to 2.3 kW for the 40.68 MHz system.

6.2.2 Generators more powerful than 2.5 kW are of limited practical analytical utility and are not commercially marketed with ICP spectrometers. The power requirements are related to torch geometry and types of samples to be analyzed. Refer to Practice E 172 for details. More power (typically 1.5 to 2 kW for a 27.12 MHz system utilizing a 20-mm outside diameter

torch and 1.2 to 1.7 kW for a 40.68 MHz generator) is required for analyzing samples dissolved in organic solvents than is needed for aqueous solutions (approximately 1.0 kW). Less power is required for small diameter torches (for example, 650 to 750 W for a 13-mm outside diameter torch).

6.3 Load Coil:

6.3.1 A coil made from copper (or another metal or an alloy with similar electrical properties) is used to transmit power from the generator to the plasma torch (see 7.6). A typical design consists of a two- to six-turn coil of about 1-in. (25-mm) diameter, made from 1/8-in. (3-mm) outside diameter and 1/16-in. (1.6-mm) inside diameter copper tubing (though larger tubing is used with two-turn coils). The tubing is fitted with ferrules or similar devices to provide a leak-free connection to a coolant, either recirculated by a pump or fed from a municipal water supply. Argon gas blown through the coil has been used to cool other load coils.

6.3.2 The high power conducted by the coil can lead to rapid oxidation, surface metal vaporization, RF arc-over and even melting if the coil is not cooled continuously.

6.3.3 A safety interlock must be included to turn off the RF generator in case of loss of coolant flow.

6.4 Impedance Matching:

6.4.1 To optimize power transfer from the generator to the induced plasma, the output impedance of the generator must be matched to the input impedance of the load coil. Some instruments include an operator-adjustable capacitor for impedance matching.

6.4.2 Alternately, RF frequency may be automatically tuned or varied in free-running fashion against a fixed capacitor-inductor network. Most modern instruments, however, incorporate an automatic impedance matching network to simplify ignition, to reduce incidence of plasma extinction when introducing sample solutions, and to optimize power transfer.

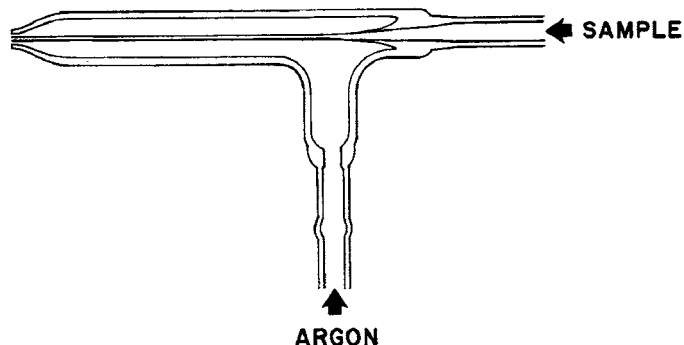

FIG. 2 Concentric Glass Nebulizer (CGN)⁴

7. Sample Introduction

7.1 The sample introduction system of an ICP instrument consists of a nebulizer, a spray chamber, and a torch.

7.2 Nebulizers:

7.2.1 Samples generally are presented to the instrument as aqueous or organic solutions. A nebulizer is employed to convert the solution to an aerosol suitable for transport into the plasma where vaporization, atomization, excitation, and emission occur.

7.2.2 Some nebulizers, designated as self-aspirating pneumatic nebulizers, operating on the Venturi principle, create a partial vacuum to force liquid up a capillary tube into the nebulizer. Precision of operation may be improved if a peristaltic pump controls the solution flow rate.

7.2.3 Other nebulizers require an auxiliary device, such as a peristaltic pump, to drive solution to the nebulizer. Generally, pump-fed nebulizers are more tolerant of high levels of dissolved solids and much less affected by suspended solids and viscosity variations.

7.2.4 If fluoride is present in solutions to be analyzed, it is necessary to employ a nebulizer fabricated from hydrofluoric acid (HF)-resistant materials (see 7.4.1.). It is possible to use the HF-resistant nebulizer for most other types of solutions, but sensitivity and precision may be degraded. An HF-resistant nebulizer may be more expensive to acquire and repair, and require greater operator proficiency and training than other nebulizers.

7.3 Self-Aspirating or Non-Pump-Fed Nebulizers:

7.3.1 Concentric Glass Nebulizers (CGN):

7.3.1.1 CGNs consist of a fine capillary through which the sample solution flows surrounded by a larger tube drawn to a fine orifice (concentric) slightly beyond the end of the central capillary (see Fig. 2). Minor variations in capillary diameter and placement affect optimal operating pressure for the sample gas flow and change the sample solution uptake rate. Uptake rates of liquid are typically 0.5 to 3 mL/min.

7.3.1.2 CGNs exhibit somewhat degraded sensitivity and precision for solutions that approach saturation or concentrations of more than a few tenths of a percent of dissolved solids. This problem can be greatly reduced by using an inner argon stream that has been bubbled through water in order to humidify the sample gas argon. Furthermore, since suspended solids may clog the tip, it is desirable to include a piece of capillary tubing of even smaller diameter in the sample solution uptake line. This action will isolate a potential clogging problem prior to clogging at the nebulizer tip.

7.3.2 Micro-Concentric Nebulizer (MCN):

7.3.2.1 To some extent, the MCN mimics the concept and function of the CGN but the MCN employs a thinner-walled poly-ether-imide capillary and TFE-fluorocarbon (or other polymer) outer body to minimize or eliminate undesirable large drop formation and facilitate HF tolerance (see Fig. 3^{4,5}). A true aerosol, as opposed to a mist, is produced consisting of only the desired smallest size droplets. Liquid uptake rates to produce similar sensitivity to CGNs are sharply reduced with the MCN. The MCN utilizes typical uptake rates of <0.1 mL/min and is HF tolerant. Unusually small sample size, low uptake rates, fast washout times, and very low drain rates characterize this nebulizer. The low uptake rate is particularly beneficial for extending limited sample volumes so that the long nebulization times encountered with sequential spectrometers undertaking multielement analysis may be successfully accomplished.

⁵ Courtesy of CETAC Technologies, a division of Transgenomic Inc., 5600 S. 42nd St., Omaha, NE.

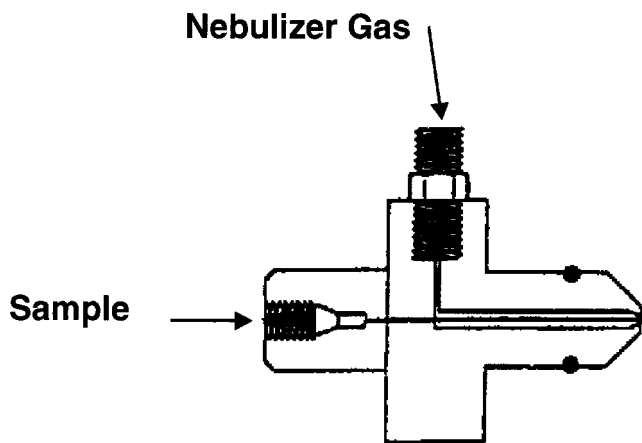

FIG. 3 Micro-Concentric Nebulizer (MCN)^{4,5}

7.3.2.2 The initial purchase cost is higher for the MCN than for the CGN but the cost may be offset by a substantial reduction in recurring hazardous waste disposal cost (for example, heavy metal salts, mineral acids, etc.). This disposal cost reduction is because of the minimal waste volume inherent with low sample uptake rates and significantly reduced drain rates. In addition, micro-autosamplers that are compatible with the MCN are available for the optimum handling of small sample volumes.

7.3.3 *Cross-Flow Nebulizer (CFN)*—Consists of two capillaries held perpendicularly and with exit tips close together, as shown in Fig. 4. This nebulizer is preadjusted by the manufacturer and is known as a fixed cross-flow nebulizer. It requires little maintenance and is very durable. Problems with high levels of dissolved and suspended solids are similar to those of the concentric glass nebulizer.

7.4 *Pump-Fed Pneumatic Nebulizers:*

7.4.1 *Grid Nebulizer*—constructed from a fine-mesh screen of acid and solvent resistant material, such as platinum, mounted vertically in an inert housing. Sample solution is pumped over the surface of the mesh. A high-velocity gas stream is directed through the openings in the screen, shearing the liquid from the wetted surface. A fine mist is produced and transported to the plasma. A second screen, parallel to the first and mounted between the first one and the spray chamber, is usually incorporated into the design to improve uniformity of droplet size and transport. A schematic diagram of a grid

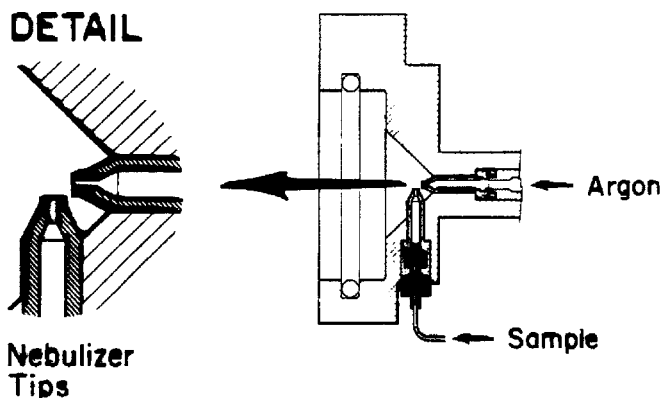

FIG. 4 Cross-Flow Nebulizer⁴

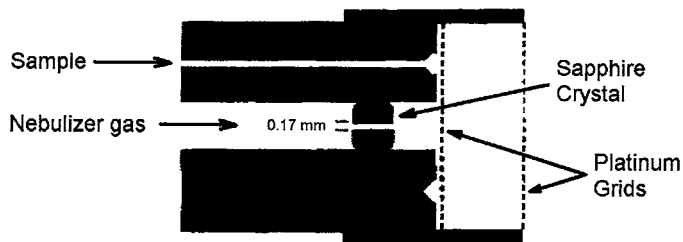

FIG. 5 Grid Nebulizer⁶

nebulizer is shown in Fig. 5.⁶ The grid nebulizer may be employed to analyze fluoride-containing solutions, but an HF-resistant spray chamber and torch must also be used.

7.4.2 *Babington, Modified Babington or V-Groove Nebulizer:*

7.4.2.1 These nebulizers operate by passing an argon gas flow through a falling film of flowing analyte solution.⁷ The falling film is typically guided by a shallow groove or channel to a pressurized argon orifice. Film thickness varies with channel depth, surface texture, cleanliness, and wettability (hydrophilicity), as well as liquid viscosity, surface tension, and sample delivery pump rate. The nebulizer does not aspirate naturally and must be pumped to fill the groove or channel with sample liquid.

7.4.2.2 This nebulizer can tolerate extremely high levels of dissolved and suspended solids, but some early versions of this device have developed a reputation for not being as sensitive or precise as a pneumatic or grid-type nebulizer. However, more recent versions easily perform as well as concentric or grid nebulizers. Most Babington nebulizers are HF-resistant. An example of a common arrangement is shown in Fig. 6. Alternate configurations may be used.

7.5 *Spray Chamber:*

7.5.1 The spray chamber provides an aerosol droplet-sorting function to ensure that only the smaller droplets (typically less than 10 μm) reach the plasma. This ensures that the plasma is not significantly overloaded with solvent. The larger droplets are condensed and drained away from the spray chamber. If a peristaltic pump is used to remove the waste liquid from the spray chamber during nebulization, the pump tubing for the drain should be of a higher flow rating than that used for the intake.

7.5.2 A positive pressure must be maintained in the spray chamber to prevent air ingress and deliver the sample aerosol to the torch. It is therefore vital to ensure that all connections between the spray chamber and the ICP torch are leak-proof and that the drain plug is secure. If a peristaltic pump under computer control is incorporated, automatic start-up and shut-down can be achieved without depleting sample solution.

7.5.3 A common ICP spray chamber is a double-pass-type fabricated of glass (see Fig. 7). If fluoride is present in solutions to be analyzed, it is necessary to employ a spray

⁶ Courtesy of Leeman Labs, Inc., 6 Wentworth Drive, Hudson, NH 03826.

⁷ This nebulizer is sometimes misnamed a cross-flow nebulizer. It is most properly named a Babington or modified Babington nebulizer after the original and pertinent patent holder.

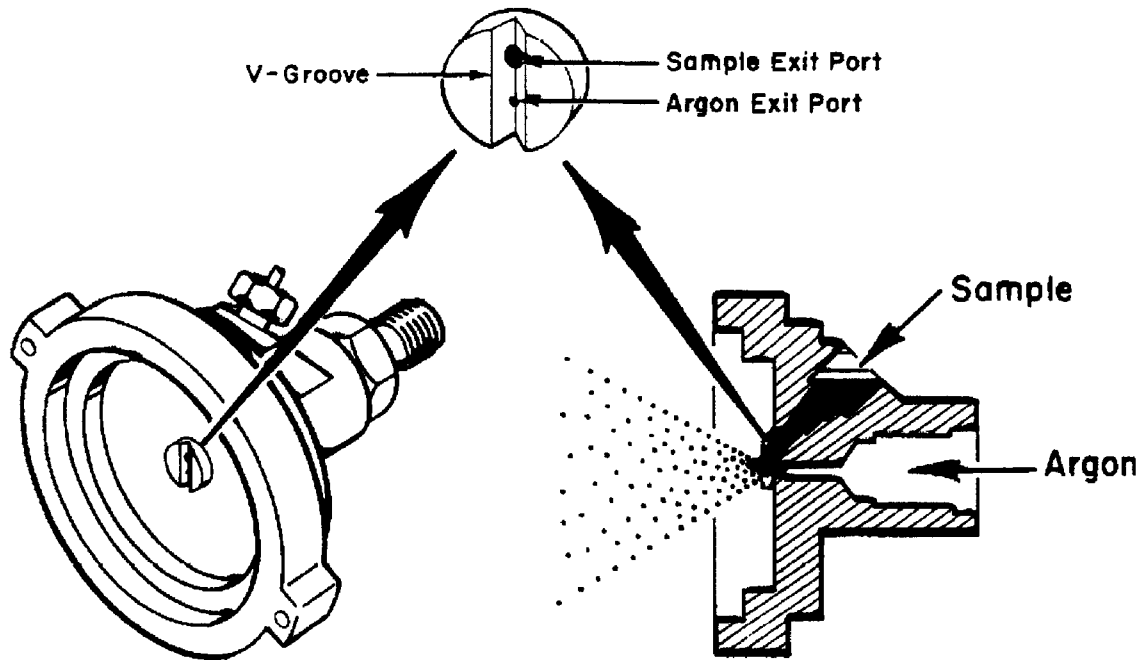

FIG. 6 Babington-Type Nebulizer⁴

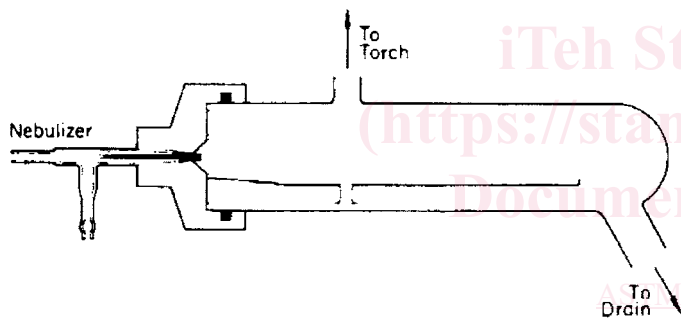

FIG. 7 Spray Chamber⁴

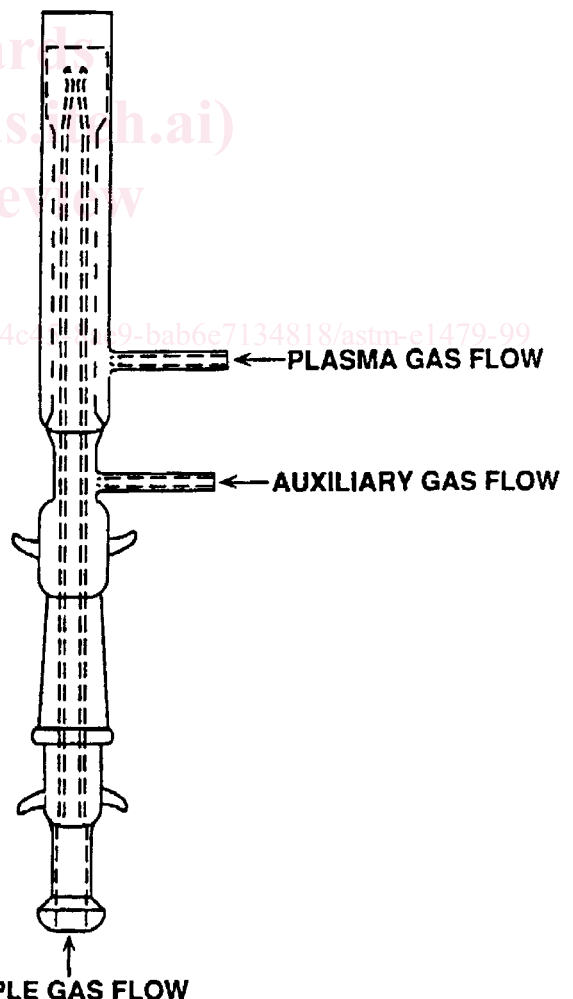

FIG. 8 Typical One-Piece Quartz Torch⁸

chamber constructed from HF-resistant materials. It is possible to use the HF-resistant spray chamber for other types of solutions.

7.6 Plasma Torch—The argon gas that forms the plasma is directed through the load coil by means of a plasma torch.

7.6.1 The classic ICP torch is constructed of three concentric quartz tubes sealed together and is known as a one-piece torch (see Fig. 8⁸). These torches produce good plasma stability and are easy to use. However, they are, in general, not HF-resistant and, if damaged, the entire torch must be replaced.

7.6.2 The demountable torch (see Fig. 9⁹) is in common use particularly since the individual tubes can be replaced without replacing the entire assembly.

7.6.3 Alternate materials of construction (typically ceramics) may be employed for analyzing solutions containing significant quantities of fluoride ion that attacks quartz.

7.6.4 In place of quartz, one-piece or demountable torches are commonly made of an HF-resistant ceramic. For demount-

⁸ Courtesy of TJA Solutions, 27 Forge Parkway, Franklin, MA 01945.

⁹ Courtesy of TJA Solutions (formerly VG Elemental), Ion Path Road Three, Winsford Cheshire, CW7 3BX UK.

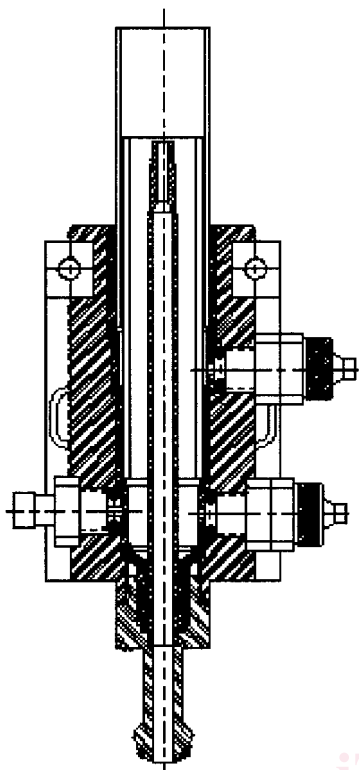

FIG. 9 Demountable Torch⁹

able torches, all tubes, or often only the central or injector tube, are made from a corrosion-resistant ceramic.

7.6.5 If fluoride-containing solutions are to be analyzed routinely, the design and performance of the prospective supplier's HF-resistant torch should be evaluated.

7.6.6 There may be significant variations in the ease of installation and operation, and in costs of repair and maintenance.

7.6.7 Alternately, it may be possible to build an HF-resistant system or acquire one from a vendor different than the manufacturer of the spectrometer.

7.6.8 Before purchasing a third-party torch system, a demonstration of both repeated plasma initiation reliability and analytical performance with the fluoride medium in the intended model spectrometer is recommended unless a satisfactory guarantee of analytical performance and initiation reliability is obtained.

7.7 Gas Flow:

7.7.1 There are usually three gas flows through the torch. The first is the outer (coolant or plasma) gas flow which is directed tangentially to the internal surface of the largest diameter portion of the torch (typically 12 to 20 L/min, although some torches are designed to operate on much lower flow rates). Second, an intermediate (auxiliary) gas flow (typically 0.5 to 1 L/min) is directed between the central tube through which the sample aerosol is introduced and the outer tube to reduce carbon formation on the injector tip when organic samples are being analyzed and to prevent the plasma from collapsing onto the injector tip. That intermediate flow, however, may also improve performance with aqueous samples. Third, an inner (sample or nebulizer) flow (typically

0.4 to 1 L/min) passes through the sample introduction device and transports the analyte through the injector tip into the plasma. The manufacturer should provide data on optimal ranges for each of the gas flows since torch geometry strongly influences optimal rates.

7.7.2 An argon sheath attachment, a device for changing the flow rate of the intermediate flow during the analysis by introducing an additional argon flow under computer control, is available. This additional flow affects the observation zone that is viewed by the spectrometer and, consequently, enhanced detection limits for the alkali metals and alkaline earths may be realized. Furthermore, the argon sheath attachment may also prevent salt encrustation in the inner tube with elevated salt concentration samples.

7.7.3 The inner gas flow rate is the most critical because it affects the injection efficiency and residence time of the sample in the plasma and, especially for a pneumatic nebulizer (see 7.3), influences transport efficiency of both analyte and solvent species. Both sensitivity and position of the maximum signal-to-noise ratio within the plasma are dependent on sample gas pressure and flow rate.

7.7.4 A conventional regulator and rotameter provide adequate stability in most cases, but a precision pressure controller or a mass flow controller (MFC) may be required in certain applications. The intermediate flow affects the vertical location of the plasma relative to the torch and load coil. Gross variations will affect accuracy and precision but an MFC is seldom, if ever, required for this flow. An MFC also may be used for the inner gas flow, but is seldom, if ever, required. The user should compare results with and without MFCs to determine their impact on performance.

7.7.5 In all but the most robust (all ceramic) torches, loss of outer gas flow through the torch will lead to rapid melting. A safety interlock must be included in the instrument design to turn off power to the RF generator in case of loss of argon pressure.

7.8 Alternate Sample Introduction Devices:

7.8.1 Ultrasonic Nebulizer (USN):

7.8.1.1 A USN with desolvation is the most generally useful alternate sampling device. In this device, the sample solution is pumped over the face of a quartz-coated crystalline transducer driven by a low-power RF generator (see Fig. 10). The apparatus is about ten times as efficient as the self-aspirating and pumped pneumatic nebulizers described in 7.3 and 7.4, respectively, and is useful for situations requiring very high sensitivity. Sensitivity is about ten times better with a USN than with self-aspirating and pumped pneumatic nebulizers. However, the USN device is more expensive and may require more maintenance than the pneumatic types.

7.8.1.2 Operation of the USN without desolvation is generally not practical because the large amount of aerosol reaching the plasma creates an excessive solvent load which reduces excitation efficiency and negates all potential sensitivity advantage. The aerosol, therefore, is passed through a heated zone followed by a condenser to limit solvent loading of the plasma.