



Designation: C16 – 03 (Reapproved 2012)

Standard Test Method for Load Testing Refractory Shapes at High Temperatures¹

This standard is issued under the fixed designation C16; the number immediately following the designation indicates the year of original adoption or, in the case of revision, the year of last revision. A number in parentheses indicates the year of last reapproval. A superscript epsilon (ϵ) indicates an editorial change since the last revision or reapproval.

1. Scope

1.1 This test method covers the determination of the resistance to deformation or shear of refractory shapes when subjected to a specified compressive load at a specified temperature for a specified time.

1.2 The values stated in inch-pound units are to be regarded as standard. The values given in parentheses are mathematical conversions to SI units that are provided for information only and are not considered standard.

1.3 *This standard does not purport to address all of the safety concerns, if any, associated with its use. It is the responsibility of the user of this standard to establish appropriate safety and health practices and determine the applicability of regulatory limitations prior to use.*

2. Referenced Documents

2.1 *ASTM Standards:*²

C862 Practice for Preparing Refractory Concrete Specimens by Casting

E220 Test Method for Calibration of Thermocouples By Comparison Techniques

2.2 *ASTM Adjuncts:*

Direct-Load Type Furnace (Oil or Gas Fired, or Electrically Fired); Lever-Load Type Furnace³

3. Significance and Use

3.1 The ability of refractory shapes to withstand prescribed loads at elevated temperatures is a measure of the high-temperature service potential of the material. By definition, refractory shapes must resist change due to high temperature; and the ability to withstand deformation or shape change when subjected to significant loading at elevated temperatures is clearly demonstrated when refractory shapes are subjected to

this test method. The test method is normally run at sufficiently high temperature to allow some liquids to form within the test brick or to cause weakening of the bonding system. The result is usually a decrease in sample dimension parallel to the applied load and increase in sample dimensions perpendicular to the loading direction. Occasionally, shear fracture can occur. Since the test provides easily measurable changes in dimensions, prescribed limits can be established, and the test method has been long used to determine refractory quality. The test method has often been used in the establishment of written specifications between producers and consumers.

3.2 This test method is not applicable for refractory materials that are unstable in an oxidizing atmosphere unless means are provided to protect the specimens.

4. Apparatus

4.1 The apparatus shall consist essentially of a furnace and a loading device. It may be constructed in accordance with Fig. 1 or Fig. 2 or their equivalent.⁴

4.1.1 The furnace shall be so constructed that the temperature is substantially uniform in all parts of the furnace. The temperature as measured at any point on the surface of the test specimens shall not differ by more than 10°F (5.5°C) during the holding period of the test or, on test to failure, above 2370°F (1300°C). To accomplish this, it may be necessary to install and adjust baffles within the furnace. A minimum of two burners shall be used. If difficulty is encountered in following the low-temperature portion of the schedule (particularly for silica brick), a dual-burner system is recommended, one to supply heat for low temperatures and another for the higher temperatures.

4.2 The temperature shall be measured either with calibrated^{5,6,7} platinum - platinum - rhodium thermocouples, each encased in a protection tube with the junction not more

¹ This test method is under the jurisdiction of ASTM Committee C08 on Refractories and is the direct responsibility of C08.01 on Strength.

Current edition approved Oct. 1, 2012. Published November 2012. Originally approved in 1917. Last previous edition approved in 2008 as C16 – 03 (2008). DOI: 10.1520/C0016-03R12.

² For referenced ASTM standards, visit the ASTM website, www.astm.org, or contact ASTM Customer Service at service@astm.org. For Annual Book of ASTM Standards volume information, refer to the standard's Document Summary page on the ASTM website.

³ Available from ASTM International Headquarters. Order Adjunct No. ADJC0016. Original adjunct produced in 1969.

⁴ Blueprints of detailed drawings of the furnaces shown in Figs. 1 and 2 are available from ASTM International. Request ADJC0016.

⁵ Test Method E220 specifies calibration procedures for thermocouples.

⁶ The National Institutes of Standards and Technology, Gaithersburg, MD 20899, will, for a fee, furnish calibrations for radiation-type pyrometers and for thermocouples.

⁷ All temperatures specified in this test conform to the International Practical Temperature Scale of 1968 (IPTS 1968) as described in *Metrologia*, Vol 5, No. 2, 1969, pp. 35–44.

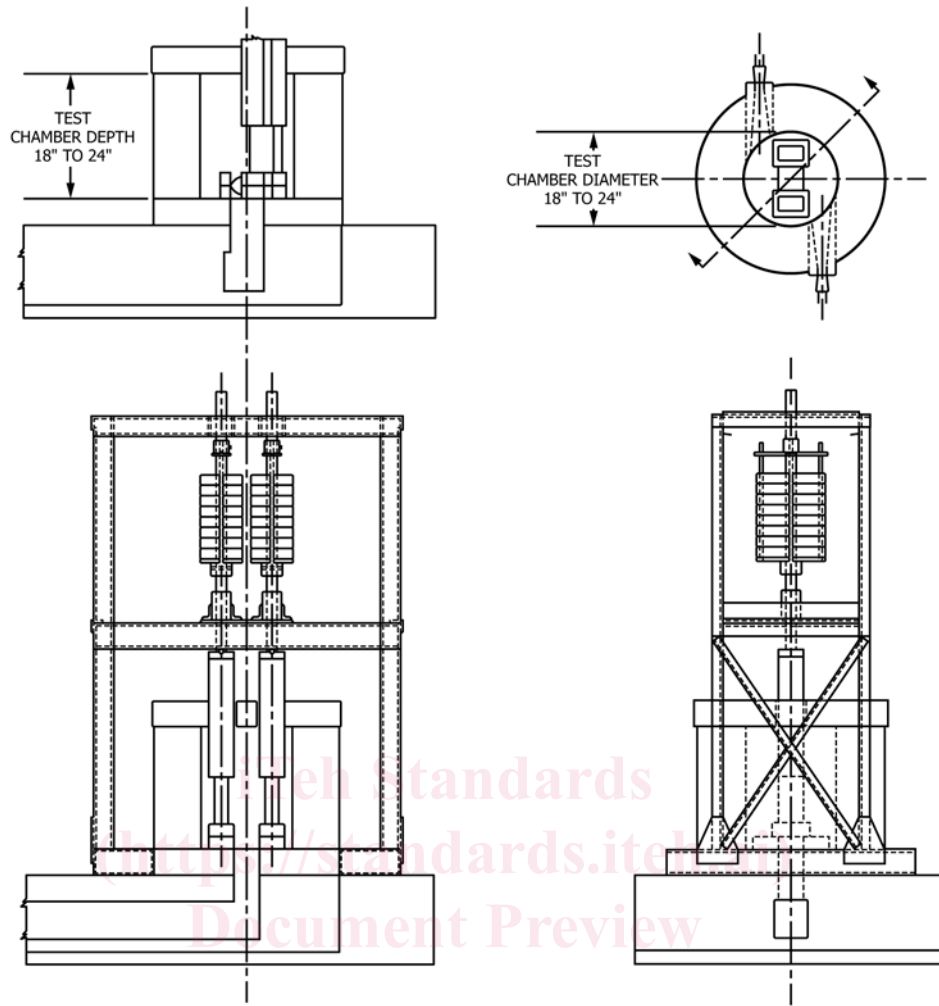

ASTM C16-03(2012)

SI Equivalents

in.	mm
18	460
24	610

NOTE 1—Dimensions are in inches.

FIG. 1 Direct-Load Type Test Furnace

than 1 in. (25 mm) from the center of the side or edge of each specimen or with a calibrated^{5,6,7} pyrometer. A recording form of temperature indicator is recommended. If the optical pyrometer is used, observations shall be made by sighting on the face of the specimens and in the same relative positions as those specified for the thermocouples.

5. Test Specimen

5.1 The test specimen shall consist of a minimum of two 9 by 4½ by 2½ or 3-in. (228 by 114 by 64 or 76-mm) straight refractory brick, or specimens of this size cut from larger refractory shapes, utilizing as far as possible existing plane surfaces.

5.2 If necessary, the ends of the specimen shall be ground so that they are approximately perpendicular to the vertical axis.

5.3 The test specimen shall be measured before testing, four observations being made on each dimension (length, width, and thickness), at the center of the faces to within ±0.02 in. (0.5 mm). The average dimensions shall be recorded, and the cross section calculated.

6. Setting the Test Specimen

6.1 The test specimen, set on end, shall occupy a position in the furnace so that the center line of the applied load coincides with the vertical axis of the specimen as indicated in Fig. 1 and Fig. 2 and shall rest on a block of some highly refractory material, neutral to the specimen, having a minimum expansion or contraction (Note 1). There shall be placed between the specimen and the refractory blocks a thin layer of highly refractory material such as fused alumina, silica, or chrome