



Designation: D2155 – 12

Standard Test Method for Determination of Fire Resistance of Aircraft Hydraulic Fluids by Autoignition Temperature¹

This standard is issued under the fixed designation D2155; the number immediately following the designation indicates the year of original adoption or, in the case of revision, the year of last revision. A number in parentheses indicates the year of last reappraisal. A superscript epsilon (ϵ) indicates an editorial change since the last revision or reappraisal.

1. Scope

1.1 This test method is used for assessing the fire resistance of hydraulic fluids used for aircraft applications by determination of the autoignition temperature of the hydraulic fluid in air at one atmosphere pressure using hypodermic syringe injection.

1.2 The values stated in inch-pound units are to be regarded as standard. The values given in parentheses are mathematical conversions to SI units that are provided for information only and are not considered standard.

1.3 *This standard is used to measure and describe the response of materials, products, or assemblies to heat and flame under controlled conditions, but does not by itself incorporate all factors required for fire hazard or fire risk assessment of the materials, products, or assemblies under actual fire conditions.*

1.4 *This standard does not purport to address all of the safety concerns, if any, associated with its use. It is the responsibility of the user of this standard to establish appropriate safety and health practices and determine the applicability of regulatory limitations prior to use.*

2. Summary of Test Method

2.1 A small metered sample of the fluid to be tested is injected with a hypodermic syringe into a heated 200-mL Erlenmeyer borosilicate glass flask containing air. The contents of the flask are observed in a darkened room for 5 min following injection of the sample or until autoignition occurs; autoignition is evidenced by the sudden appearance of a flame inside the flask. The lowest flask temperature at which autoignition occurs for a series of prescribed sample volumes is taken to be the autoignition temperature of the fluid in air at one atmosphere pressure.

¹ This test method is under the jurisdiction of ASTM Committee D02 on Petroleum Products and Lubricants and is the direct responsibility of Subcommittee D02.N0 on Hydraulic Fluids.

Current edition approved July 1, 2012. Published November 2012. Originally approved in 1966. Last previous edition approved in 1976 as D2155-66(1976) which was withdrawn August 1980 and reinstated in July 2012. DOI: 10.1520/D2155-12

3. Apparatus

3.1 The apparatus, shown schematically in Figs. 1 and 2, shall conform to the requirements prescribed in 3.2 to 3.6.

3.2 *Furnace*—The furnace shall consist of a 5-in. (127-mm) internal diameter aluminum cylinder, 5 in. long, circumferentially wound with an electric heater, a Transite cover ring neck heater, three-neck heater supports, Transite flask guide ring, base heater, and suitable refractory insulating material and retaining shell. Temperature control shall be achieved by the use of suitable autotransformers or rheostats, thermocouples, and a suitable potentiometer.

3.3 *Hypodermic Syringe*—A 0.25 or 1-cm³ hypodermic syringe equipped with a 2-in. (50.8-mm) No. 18 stainless steel needle and calibrated in units of 0.01 cm³ should be used to inject the sample into the heated test flask.

3.4 *Test Flask*—The test flask in Fig. 3 shall be a commercial 200-mL Erlenmeyer borosilicate glass flask.² A new flask shall be used for tests on each product; should the flask become visibly coated with residue before the completion of tests on each product, the final series of tests should be conducted with a new flask.

3.5 *Thermocouples*—Three calibrated 20-gage iron-constantan thermocouples shall be used in determining the flask temperature. These shall be mounted in the furnace so as to contact the walls of the flask 1 and 2 in. (25 to 51 mm) below the bottom of the neck heater and under the base of the flask near its center.

3.6 *Timer*—An electric timer or stopwatch calibrated in 0.1 or 0.2-s intervals shall be used to determine the time lag before ignition (time interval between the instant of sample injection and that of ignition as evidenced by the appearance of the flame).

4. Procedure

4.1 *Temperature Control*—Adjust the temperature of the furnace so that the temperatures at the top, center, and bottom

² The sole source of supply of the apparatus known to the committee at this time is Schott of North America Inc., 555 Taxter Road, Elmsford, NY. If you are aware of alternative suppliers, please provide this information to ASTM International Headquarters. Your comments will receive careful consideration at a meeting of the responsible technical committee,¹ which you may attend.

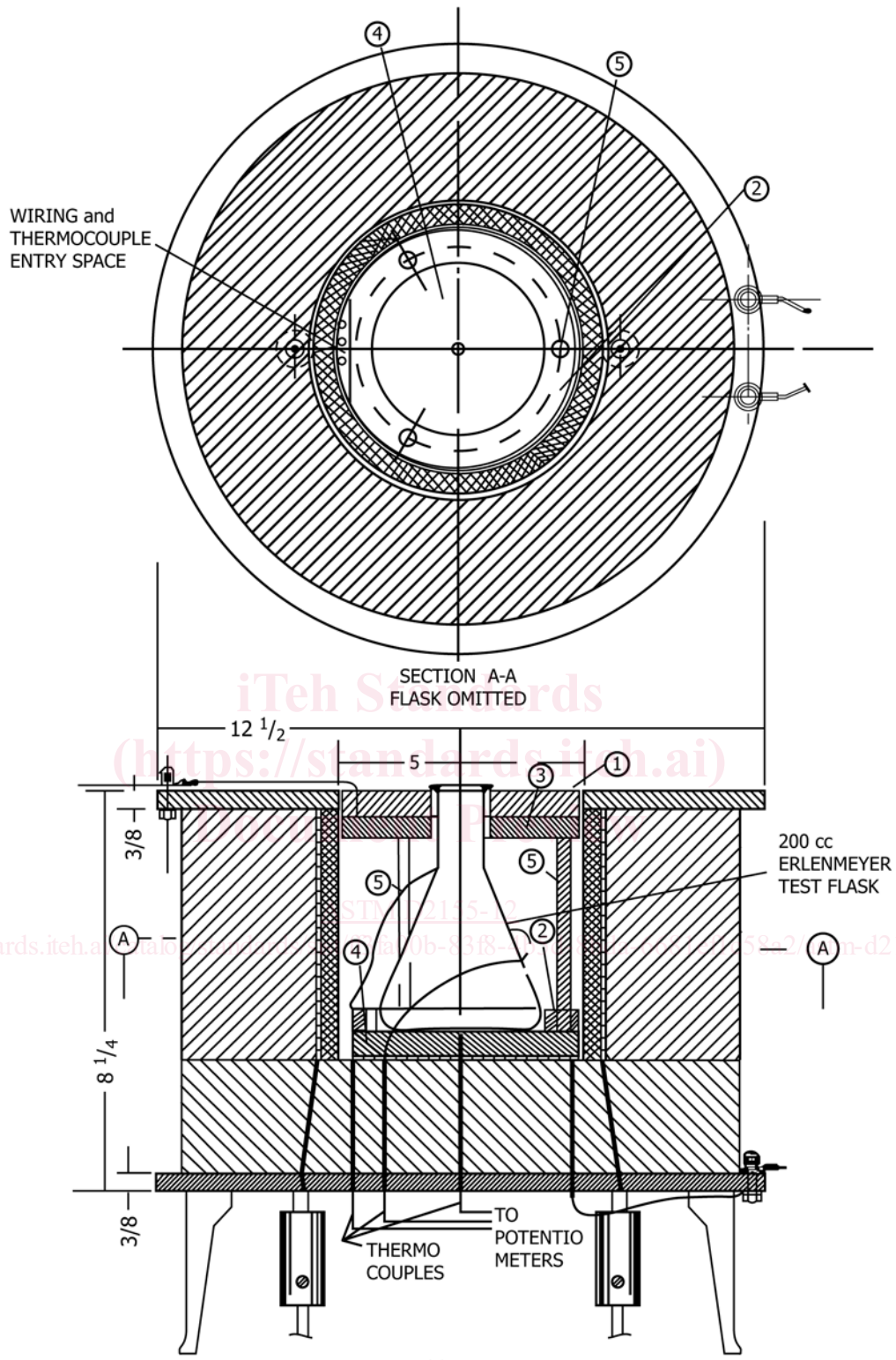

- (1) Cover Ring.
- (2) Flask Guide Ring.
- (3) Neck Heater.
- (4) Base Heater.
- (5) Neck Heater Support.

FIG. 1 Furnace Details