



Designation: E1258 – 88 (Reapproved 2012)

Standard Test Method for Airflow Calibration of Fan Pressurization Devices¹

This standard is issued under the fixed designation E1258; the number immediately following the designation indicates the year of original adoption or, in the case of revision, the year of last revision. A number in parentheses indicates the year of last reapproval. A superscript epsilon (ϵ) indicates an editorial change since the last revision or reapproval.

1. Scope

1.1 This test method covers the airflow measurement calibration techniques for fan pressurization systems used for measuring air leakage rates through building envelopes.

1.2 This test method is applicable to systems used for air leakage measurement as described in Practice E779.

1.3 This test method involves the installation of the fan pressurization system in a calibration chamber. Use of the fan pressurization system in an actual building may introduce additional errors in the airflow measurement due to operator influence, interference of internal partitions and furnishings, weather effects, and other factors.

1.4 The proper use of this test method requires a knowledge of the principles of airflow and pressure measurement.

1.5 This standard includes two basic procedures, a preferred procedure, based on ASHRAE 51/AMCA 210, and an optional procedure based on a nonstandard airflow measurement technique, commonly used by manufacturers of fan pressurization devices, but which has not been compared with standard airflow measurement techniques.

1.6 The values stated in SI units are to be regarded as standard. No other units of measurement are included in this standard.

1.7 *This standard does not purport to address all of the safety concerns, if any, associated with its use. It is the responsibility of the user of this standard to establish appropriate safety and health practices and determine the applicability of regulatory limitations prior to use.*

2. Referenced Documents

2.1 *ASTM Standards:*²

E631 *Terminology of Building Constructions*

¹ This test method is under the jurisdiction of ASTM Committee E06 on Performance of Buildings and is the direct responsibility of Subcommittee E06.41 on Air Leakage and Ventilation Performance.

Current edition approved Oct. 1, 2012. Published October 2012. Originally approved in 1988. Last previous edition approved in 2008 as E1258 – 88 (2008). DOI: 10.1520/E1258-88R12.

² For referenced ASTM standards, visit the ASTM website, www.astm.org, or contact ASTM Customer Service at service@astm.org. For Annual Book of ASTM Standards volume information, refer to the standard's Document Summary page on the ASTM website.

E779 *Test Method for Determining Air Leakage Rate by Fan Pressurization*

2.2 *American Society of Heating, Refrigerating, and Air-Conditioning Engineers Standard:*³

ASHRAE 51/AMCA 210 *Laboratory Methods for Testing Fans for Rating*

2.3 *American Society of Mechanical Engineers Standard:*⁴

ASME MFC-3M *Standard Measurement of Fluid Flow in Pipes Using Orifice, Nozzle, and Venturi*

3. Terminology

3.1 *Definitions*—For definitions used in this test method, see Terminology E631.

3.2 *Definitions of Terms Specific to This Standard:*

3.2.1 *ambient conditions, n*—conditions in the space from which air is drawn into the calibration chamber and into which the chamber air is expelled.

3.2.2 *chamber, n*—an enclosure of rectangular or circular cross section to simulate the entrance and exit conditions that the fan is expected to encounter in service.

3.2.3 *fan air density, n*—density of air at the fan inlet expressed in kilograms per cubic metre.

3.2.4 *fan airflow rate, n*—volumetric airflow rate at the fan air density expressed in cubic metres per second.

3.2.5 *fan outlet area, n*—gross inside area measured in the plane of the fan outlet opening expressed in square metres.

3.2.6 *fan pressure difference, n*—the static pressure difference between two stations expressed in pascals, measured using the static pressure taps described in Fig. 1. One station is located within the chamber between the fan and the nearest flow conditioners. The other station is outside the chamber.

3.2.7 *fan pressurization system, n*—a device for measuring the air leakage rate of a building envelope under controlled pressurization or depressurization of the building interior. The system includes controllable air-moving equipment, an airflow rate measuring system, and a device for measuring the pressure

³ Available from American Society of Heating, Refrigerating, and Air-Conditioning Engineers, Inc. (ASHRAE), 1791 Tullie Circle, NE, Atlanta, GA 30329, <http://www.ashrae.org>.

⁴ Available from American Society of Mechanical Engineers (ASME), ASME International Headquarters, Three Park Ave., New York, NY 10016-5990, <http://www.asme.org>.

Surface shall be smooth and free from irregularities within $20 D_s$ of hole. Edge of hole shall be square and free from burrs.

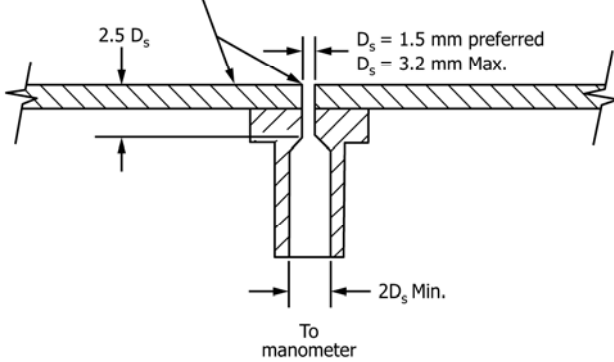

FIG. 1 Static Pressure Tap Specifications

3.2.11 *nozzle*, n —a gradually tapered constriction, of very precise elliptical shape, used in airflow rate measurement (see Fig. 2).

3.2.12 *nozzle chamber pressure difference*, n —static pressure difference measured across a nozzle or bank of nozzles when nozzles are installed in a chamber expressed in pascals.

3.2.13 *nozzle throat diameter*, n —diameter of nozzle discharge end expressed in square metres.

3.2.14 *nozzle throat pressure difference*, n —static pressure difference across the nozzle in a duct measured with throat taps expressed in pascals (see Fig. 2).

3.2.15 *orifice*, n —a sharp-edged circular constriction used in airflow measurement (see Fig. 3).

3.2.16 *orifice pressure difference*, n —static pressure difference measured across an orifice when the orifice is installed in a chamber expressed in pascals.

3.2.17 *revolution-per-minute (r/min) door*, n —a fan pressurization system with a calibration that relates the fan airflow rate to the fan speed.

3.2.18 *signal door*, n —a fan pressurization system with a calibration that relates the fan airflow rate to an output signal other than fan speed.

3.2.19 *transformation piece*, n —an element to connect a duct with a measuring station to a fan when the fan connection is a different size than the duct (see Fig. 4).

difference across the building envelope. Such a system is often referred to as a blower door.

3.2.8 *fan signal*, n —an output from a fan pressurization system (other than fan speed) that is related to fan airflow rate by the system calibration, such as the static pressure difference across a constriction that is integral to the system.

3.2.9 *fan speed*, n —speed of rotation of the fan impeller expressed in inverse seconds.

3.2.10 *flow conditioners*, n —a combination of screens or perforated plates located within the calibration chamber to reduce pressure disturbances within the chamber.

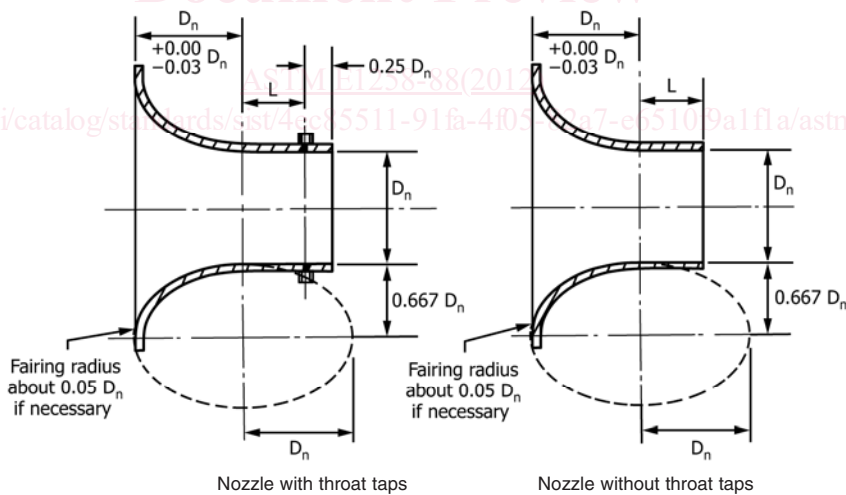

Nozzle with throat taps

Nozzle without throat taps

NOTE 1—Nozzle throat dimension L shall be either $0.6 D_n \pm 0.005 D_n$ (recommended) or $0.5 D_n \pm 0.005 D_n$.

NOTE 2—Nozzle shall have elliptical section as shown. Two and three radii approximations to the elliptical form that do not differ at any point in the normal direction more than 1.5 % D_n from the elliptical form may be used. The outlet edge of the nozzle shall be square, sharp, and free from burrs, nicks, or roundings.

NOTE 3—The nozzle throat shall be measured (to an accuracy of $0.001 D_n$) at the minor axis of the ellipse and the nozzle exit. At each place, four diameters, approximately 45° apart must be within $\pm 0.002 D_n$ of the mean. At the entrance to the throat the mean may be $0.002 D_n$ greater, but no less than the mean at the nozzle exit.

NOTE 4—The nozzle surface shall fair smoothly so that a straightedge may be rocked over the surface without clicking and the surface waves shall not be greater than $0.001 D_n$ peak to peak.

NOTE 5—When nozzles are used in a chamber, either of the types shown above may be used. Where a nozzle discharges directly to a duct, nozzles with throat taps shall be used, and the nozzle outlet should be flanged.

NOTE 6—Throat tap nozzles shall have four static pressure taps 90° apart connected to a piezometer ring.

FIG. 2 Nozzle Specifications

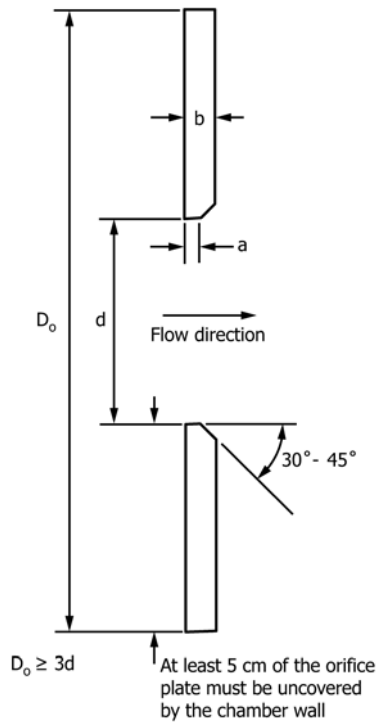

Recommended Plate Thickness, b
 1.5 mm for d up to 150 mm
 2.5 mm for d up to 300 mm
 3.2 mm for d up to 600 mm
 4.5 mm for d up to 1200 mm
 Recommended Edge Thickness, a
 Less than $0.02 d$

NOTE 1—For thin plates ($b < 0.02 d$), there is no need for beveling the edge of the orifice.

FIG. 3 Sharp-Edged Orifice Design

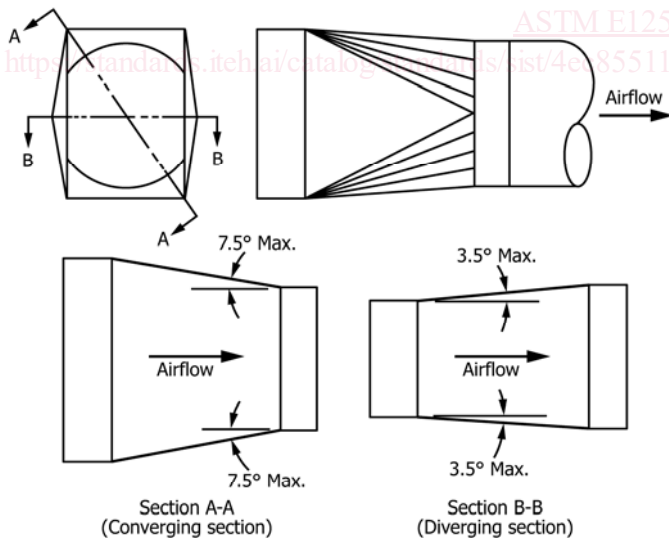

FIG. 4 Transformation Piece

4. Summary of Test Method

4.1 This test method contains two procedures for calibrating fan pressurization devices, a preferred procedure based on ASHRAE 51/AMCA 210, and an optional procedure employing an orifice in a chamber.

4.2 Both procedures involve the installation of the fan pressurization system in a chamber.

4.3 The calibration consists of a comparison of the airflow rate through the fan pressurization system measured by the system itself, and the airflow rate measured in the calibration facility. In the preferred procedure, three modes of airflow measurement are acceptable: (1) a nozzle or bank of nozzles in the chamber, (2) a traverse in a duct using a pitot tube (see Fig. 5), and (3) a nozzle in a duct. Other airflow rate measurement techniques in a duct can be used such as orifice plates (ASME MFC-3M) or constant injection tracer gas methods.⁵ In order for an alternative airflow rate measurement technique to be included as a preferred procedure, the errors introduced by the procedure must be demonstrated not to exceed those introduced by a nozzle or pitot traverse. In the optional procedure, the airflow is measured with a series of sharp-edged orifices installed in the wall of the chamber.

4.4 The calibration must include measurement points that cover a specific range in both fan pressure difference and fan airflow rate.

5. Significance and Use

5.1 The fan pressurization procedure provides a relatively fast evaluation of the airtightness of building envelopes. In order for the accuracy of the test results to be known, the airflow rate measurement technique of the fan pressurization system must be calibrated.

5.2 This test method is applicable to fan pressurization systems that are installed in an opening in the building

⁵ Persily, A. K., "Air Flow Calibration of Building Pressurization Devices," NBSIR 84-2849, National Bureau of Standards, 1984.

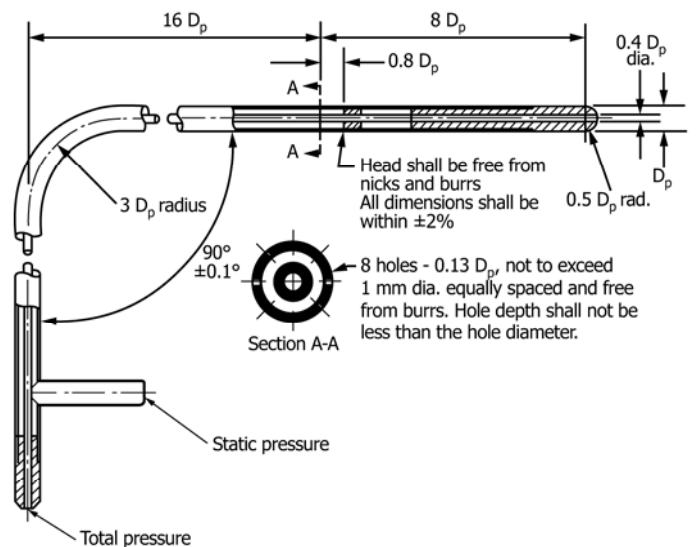

NOTE 1—Surface finish shall be $1 \mu\text{m}$ or better. The static orifices may not exceed 1 mm in diameter. The minimum pitot tube stem diameter recognized under this standard shall be 2.5 mm. In no case shall the stem diameter exceed $\frac{1}{30}$ of the test duct diameter.

FIG. 5 Pitot Tube Specifications

envelope, as opposed to pressurization techniques involving the mechanical ventilation system of the building.

5.3 The technique of pressurization testing of buildings puts specific requirements on the calibration of fan pressurization systems. The calibration must cover the range of fan pressure differences (approximately 12.5 to 75 Pa) that is induced during pressurization tests. The calibration must also cover a range in fan airflow rates corresponding to the range in building size and airtightness that the fan pressurization system will encounter in the field.

5.4 The fan pressurization system must be calibrated in both directions of airflow used to pressurize and depressurize a building if the system airflow direction is reversible. These two calibrations can be conducted using the various setups described in this test method; however some of the setups can be combined such that a single calibration facility can be used to calibrate the fan in both directions. Such a single setup may involve moving the fan pressurization system from one end of the chamber to the other, reversing the orientation of the system at the same end of the chamber, or it may not require moving the system at all.

5.5 The calibration technique is applicable to the two basic types of fan pressurization systems in use, r/min doors and signal doors.

5.6 For fan pressurization systems that operate in multiple ranges of airflow rate, the system must be calibrated in each range.

5.7 The calibration technique is intended to provide a complete calibration of a fan pressurization system. After calibrating several systems of an identical or similar design, the fan airflow rate may be found to be independent of certain parameters such as fan pressure difference. Other simplifying relations between fan airflow rate and fan speed or fan signal may be observed. If these relations are observed, a manufacturer or other calibrator may choose to simplify the calibration procedure by reducing the number of calibration points.

5.8 The use of fan pressurization systems in actual buildings introduces additional factors that may cause errors in the airflow rate measurement that are not accounted for by the calibration. These factors include operator and weather effects and interference from internal partitions and other obstructions.

6. Hazards

6.1 Provide secure guards and cages for fans and motors to prevent accidental contact with any moving parts of the equipment.

6.2 When the calibration is being conducted, a large volume of air is being drawn into and forced out of the apparatus. Exercise care to prevent any objects from being knocked down or blown around the test area.

6.3 Noise may be generated by the moving air. Make hearing protection equipment available for personnel involved in the testing.

6.4 Design the ducts, chamber, and other equipment utilized to withstand the pressure and other forces to be encountered.

7. Apparatus

7.1 The calibration facility must include the following components:

7.1.1 Preferred Procedure:

7.1.1.1 *Chamber*—An enclosure of rectangular or circular cross section with characteristic dimension, M . In the case of a rectangular cross section, the height H shall be at least 2.1 m, the width W shall be at least 2.4 m, and M is given by $\sqrt{4HW/\pi}$. In the case of a circular cross section, the chamber diameter shall be at least 2.5 m and M is equal to the chamber diameter. When multiple nozzles are used in a chamber, the chamber must be large enough to accommodate all the nozzles as described in 7.1.2.1 and 7.1.2.2.

7.1.1.2 *Flow Conditioners*—A combination of screens or perforated plates located in the chamber to reduce pressure disturbances within the enclosure. These air to be located within the chamber in accordance with 7.1.2. Where a measuring plane is located downstream of the flow conditioners, the flow conditioners are provided to ensure a substantially uniform flow ahead of the measuring plane. Where a measuring plane is located upstream of the flow conditioners, the purpose of these screens is to absorb some of the kinetic energy of the upstream jet, and allow its normal expansion as if in an unconfined space. Screens of square-mesh round wire with open areas of 50 to 60 % are suggested and several will usually be needed. Any combination of screens or perforated plates that provide this flow conditioning may be used.

7.1.1.3 *Airflow Rate Measurement System*, for measuring the fan airflow rate. Acceptable systems include a nozzle or bank of nozzles within the chamber, a nozzle in a duct, or a pitot traverse in a duct in accordance with 7.1.2.

7.1.1.4 *Flow Straighteners*, for straightening the flow upstream of the measuring stations when the airflow rate measurement system uses a nozzle in a duct or a pitot traverse in a duct. The downstream plane of the straightener shall be located between 5 and 5.25 duct diameters upstream of the plane of the pitot traverse or nozzle. A recommended form for the straightener is shown in Fig. 6. The dimension D is the inside diameter of the duct. The dimension y , which is the thickness of the straightener elements, shall not exceed 0.005 D .

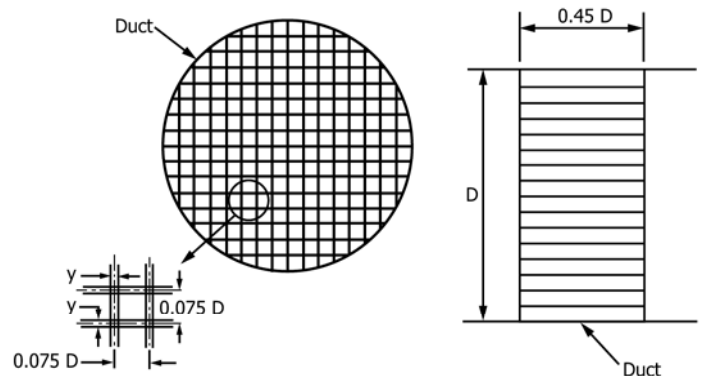

NOTE 1—All Dimensions shall be within $\pm 0.005 D$ except y which shall not exceed $0.005 D$.

FIG. 6 Flow Straightener Specifications