



Designation: F1140 – 07(Reapproved 2012)

# Standard Test Methods for Internal Pressurization Failure Resistance of Unrestrained Packages<sup>1</sup>

This standard is issued under the fixed designation F1140; the number immediately following the designation indicates the year of original adoption or, in the case of revision, the year of last revision. A number in parentheses indicates the year of last reapproval. A superscript epsilon ( $\epsilon$ ) indicates an editorial change since the last revision or reapproval.

## 1. Scope

1.1 These test methods explain the procedure for determining the ability of packages to withstand internal pressurization.

1.2 The burst test increasingly pressurizes the package until the package fails.

1.3 The creep test maintains a specified pressure for a specified time or until the package fails.

1.4 *This standard does not purport to address all of the safety concerns, if any, associated with its use. It is the responsibility of the user of this standard to establish appropriate safety and health practices and determine the applicability of regulatory limitations prior to use.*

## 2. Referenced Documents

2.1 *ASTM Standards:*<sup>2</sup>

D1898 Practice for Sampling of Plastics (Withdrawn 1998)<sup>3</sup>

D4332 Practice for Conditioning Containers, Packages, or Packaging Components for Testing

F88 Test Method for Seal Strength of Flexible Barrier Materials

## 3. Terminology

3.1 *Definitions of Terms Specific to This Standard:*

3.1.1 *flexible*—indicates a material of the proper flexural strength and thickness to permit a turn back at an appropriate 180° angle. In order to fulfill all terms of the definition, at least one of the sealed materials must be flexible.

3.1.2 *package failure*—refers to rupture of seal or material.

3.1.3 *restraint*—a mechanism that prevents package movement during inflation.

<sup>1</sup> These test methods are under the jurisdiction of ASTM Committee F02 on Flexible Barrier Packaging and are the direct responsibility of Subcommittee F02.20 on Physical Properties.

Current edition approved Nov. 1, 2012. Published November 2012. Originally approved in 1988. Last previous edition approved in 2007 as F1140–07. DOI: 10.1520/F1140-07R12.

<sup>2</sup> For referenced ASTM standards, visit the ASTM website, www.astm.org, or contact ASTM Customer Service at service@astm.org. For *Annual Book of ASTM Standards* volume information, refer to the standard's Document Summary page on the ASTM website.

<sup>3</sup> The last approved version of this historical standard is referenced on www.astm.org.

## 4. Summary of Test Method

4.1 *Test Method A (Burst Test)*—Packages are tested in an apparatus that internally pressurizes the package until the package fails. The pneumatic supply and pressurization equipment need the capability to maintain an increasing pressure until the package bursts. The test measure is the maximum pressure detected before the package fails.

4.2 *Test Method B<sub>1</sub> (Creep Test)*—Packages are tested in apparatus that internally pressurizes the package to a specified pressure and maintains that internal package pressure for a specific time. The test measure is pass/fail.

4.3 *Test Method B<sub>2</sub> (Creep to Failure)*—Packages are creep-tested and held until the package fails. Test setup is similar to that of the Creep Test except the pressure setting will need to be higher to ensure the package fails in a reasonable amount of time (that is, about 15 s). The test measure is the time until failure.

## 5. Significance and Use

5.1 These test methods provide a rapid means of evaluating tendencies for package failure when the package is exposed to a pressure differential. Pressure differentials may occur during processes such as sterilization and transportation.

5.2 These test methods are frequently used to quickly evaluate packages during the manufacturing process and at various stages of the package's life cycle.

5.3 If correlations between pieces of test equipment are to be made, it is important that all parameters of the test method be exactly the same. Typical parameters may include, but are not limited to, package size, material, seal configuration, test equipment, rate of air flow into the package, sensitivity (machine response to pressure drop), and position of test article (see Fig. 1).

5.4 These test methods do not necessarily provide correlation with actual package seal strength as typically measured using Test Method F88 (or equivalent).

## 6. Apparatus

6.1 Packages are tested under unrestrained conditions as follows:

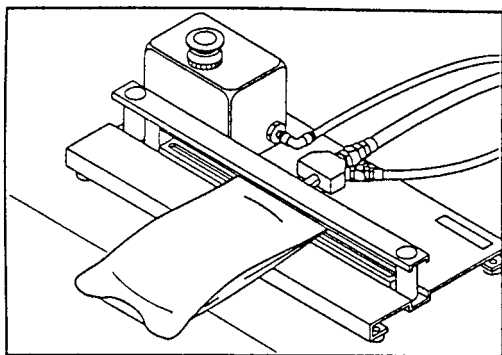

NOTE 1—The sample is inserted in the test clamp and is left unsupported and untouched during testing.

(a) Position 1

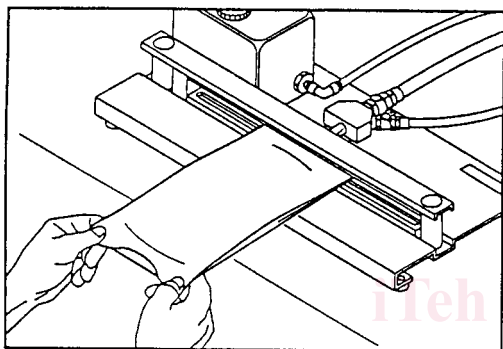

NOTE 2—The sample is inserted in the test clamp and is held firmly enough to keep the package horizontal and sealed end straight during inflation without putting undue pressure on the seal. This technique limits curling of the pouch, which may effect test results. This technique requires training for repeatability.

(b) Position 2

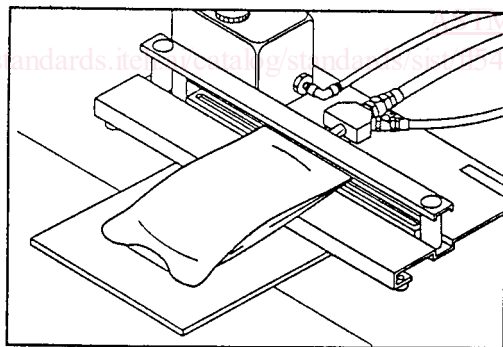

NOTE 3—The sample is inserted in the test clamp and left untouched during testing, but is supported underneath.

(c) Position 3

FIG. 1 Open Package Test Positions

6.1.1 *Open Package Tester*, used to test flexible packages with one opened side.

6.1.2 *Closed Package Tester*, internally pressurizes the completely sealed package through a puncture.

6.2 The test apparatus for both open and closed package testing shall include the following:

- 6.2.1 *Means of Measuring the Pressure Inside the Package*,
- 6.2.2 *Timer*; and

6.2.3 *Pressure Regulator*, intended to maintain steady or increasing pressure in the package.

NOTE 1—If the pressure regulator cannot provide the necessary volume, the porosity of the sample may need to be limited. (See Appendix X1.)

## 7. Sampling

7.1 Choose the number of test specimens to permit an adequate determination of representative performance. Practice D1898 provides guidance to test specimen selection. Testing of specimens with visual defects or other deviations from normality may or may not be appropriate, depending on the purpose of investigation. Indiscriminate elimination of defects can bias results.

## 8. Conditioning

8.1 *Standard Test Conditions*—Condition packages and conduct testing in accordance with Practice D4332.

8.2 If the test methods are conducted in other than standard test conditions, record the temperature and relative humidity at the time of the test method.

## 9. Procedure

9.1 *Test Method A (Burst Test)*—Place the package in the apparatus and increase the internal pressure until a failure occurs.

### 9.1.1 Open Package Test:

9.1.1.1 *Package Preparation*—The package may be tested with or without the product enclosed. Record the package test preparation.

9.1.1.2 Place the package in the test apparatus, and set the specified parameters. The open package tester must be adjusted such that the tester does not restrain the package from forming its normal unrestricted height at the time of the burst.

NOTE 2—The package is typically positioned in one of the positions shown in Fig. 1. Different positions may result in different test values and, therefore, the final report should specify which position was chosen.

9.1.1.3 Begin the test method by starting the inflation process. The rate of pressurization may affect the test results and must not exceed the response rate of the pressure indicator. Continue pressurization until a failure occurs.

9.1.1.4 Visually examine the package, and note the position and type of failure (material or seal) and the pressure at which it occurred.

### 9.1.2 Closed Package Test:

9.1.2.1 *Package Preparation*—The package may be tested with or without the product enclosed. Record the package test preparation.

9.1.2.2 Position the completely sealed package in the test apparatus and carefully insert the pressurization entry device (see Fig. 2). The center of the package is the preferred point of entry. Location variations of the entry point may affect the results of the test. Record the location of entry and perform all sample testing at this same location.

NOTE 3—It is important not to damage other package surfaces when inserting the needle. If the package material tears easily, reinforce the point of entry with tape or equivalent.

9.1.2.3 Begin the test method by starting the inflation process. The rate of pressurization may affect the test results