



Standard Specification for Installation of Lathing and Furring to Receive Interior and Exterior Portland Cement-Based Plaster¹

This standard is issued under the fixed designation C1063; the number immediately following the designation indicates the year of original adoption or, in the case of revision, the year of last revision. A number in parentheses indicates the year of last reappraisal. A superscript epsilon (ϵ) indicates an editorial change since the last revision or reappraisal.

This standard has been approved for use by agencies of the Department of Defense.

1. Scope*

1.1 This specification covers the minimum requirements for lathing and furring for the application of exterior and interior portland cement-based plaster as in Specification **C926** or Specification **C841**.

1.2 Where a fire resistance rating is required for plastered assemblies and constructions, details of construction shall be in accordance with reports of fire tests of assemblies that have met the requirements of the fire rating imposed.

1.3 Where a specific degree of sound control is required for plastered assemblies and constructions, details of construction shall be in accordance with official reports of tests conducted in recognized testing laboratories in accordance with the applicable requirements of Test Method **E90**.

1.4 The values stated in inch-pound units are to be regarded as standard. The values given in parentheses are mathematical conversions to SI units that are provided for information only and are not considered standard.

2. Referenced Documents

2.1 *ASTM Standards:*²

A641/A641M Specification for Zinc-Coated (Galvanized) Carbon Steel Wire

A653/A653M Specification for Steel Sheet, Zinc-Coated (Galvanized) or Zinc-Iron Alloy-Coated (Galvannealed) by the Hot-Dip Process

B69 Specification for Rolled Zinc

B221 Specification for Aluminum and Aluminum-Alloy Extruded Bars, Rods, Wire, Profiles, and Tubes

C11 Terminology Relating to Gypsum and Related Building Materials and Systems

C841 Specification for Installation of Interior Lathing and Furring

C847 Specification for Metal Lath

C926 Specification for Application of Portland Cement-Based Plaster

C933 Specification for Welded Wire Lath

C954 Specification for Steel Drill Screws for the Application of Gypsum Panel Products or Metal Plaster Bases to Steel Studs from 0.033 in. (0.84 mm) to 0.112 in. (2.84 mm) in Thickness

C1002 Specification for Steel Self-Piercing Tapping Screws for the Application of Gypsum Panel Products or Metal Plaster Bases to Wood Studs or Steel Studs

C1032 Specification for Woven Wire Plaster Base

D1784 Specification for Rigid Poly(Vinyl Chloride) (PVC) Compounds and Chlorinated Poly(Vinyl Chloride) (CPVC) Compounds

D4216 Specification for Rigid Poly(Vinyl Chloride) (PVC) and Related PVC and Chlorinated Poly(Vinyl Chloride) (CPVC) Building Products Compounds

E90 Test Method for Laboratory Measurement of Airborne Sound Transmission Loss of Building Partitions and Elements

3. Terminology

3.1 *Definitions*—For definitions relating to Ceilings and Walls, see Terminology **C11**.

3.2 *Definitions of Terms Specific to This Standard:*

3.2.1 *barrier wall, n*—type of wall system that is intended to block or interrupt the movement of water to the interior.

3.2.2 *building enclosure, n*—system of building assemblies and materials designed and installed in such a manner as to provide a barrier between different environments.

*A Summary of Changes section appears at the end of this standard

3.2.3 *control joint, n*—a joint that accommodates movement of plaster shrinkage and curing along predetermined, usually straight, lines.

3.2.4 *drainage plane, n*—surface between the back of the cladding and the front of the water barrier which resists liquid moisture infiltration and provides for gravitational flow to a collection or exhaust location.

3.2.5 *drainage space, n*—volumetric area that allows the gravitational flow of liquid moisture to a collection or exhaust location.

3.2.6 *drainage wall, n*—a wall system in which the cladding provides a substantial barrier to water intrusion, and which also incorporates a concealed water resistive barrier over which drainage will occur.

3.2.7 *expansion joint, n*—a joint that accommodates movement beyond plaster shrinkage and curing.

NOTE 1—For design consideration of control and expansion joints, see Annex A2.3.1.2 of Specification C926.

3.2.8 *framing member, n*—studs, joist, runners (track), bridging, bracing, and related accessories manufactured or supplied in wood or light gauge steel.

3.2.9 *hangers, n*—wires or steel rods or straps used to support main runners for suspended ceilings beneath floor or roof constructions.

3.2.10 *inserts, n*—devices embedded in concrete structural members to provide a loop or opening for attachment of hangers.

3.2.11 *saddle tie, n*—see Figs. 1 and 2.

3.2.12 *self-furring, adj*—a metal plaster base manufactured with evenly-spaced indentations that hold the body of the lath approximately 1/4 in. (6.4 mm) away from solid surfaces to which it is applied.

3.2.13 *water barrier, n*—a material that prevents the infiltration of liquid moisture through the building enclosure system.

3.2.14 *water barrier system, n*—a combination of water barrier assemblies that prevent the infiltration of liquid moisture through the building enclosure system and facilitates its gravitational flow to a collection or exhaust location.

4. Delivery of Materials

4.1 All materials shall be delivered in the original packages, containers, or bundles bearing the brand-name and manufacturer's (or supplier's) identification.

5. Storage of Materials

5.1 All materials shall be kept dry. Materials shall be stacked off the ground, supported on a level platform, and protected from the weather and surface contamination.

5.2 Materials shall be neatly stacked with care taken to avoid damage to edges, ends, or surfaces.

5.3 Paper backed metal plaster bases shall be handled carefully in delivery, storage, and erection to prevent puncturing or removal of paper.

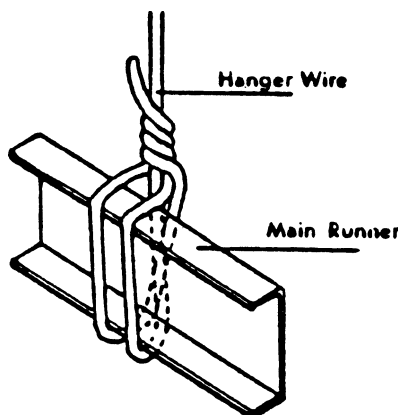

FIG. 1 Saddle Tie

¹ This specification is under the jurisdiction of ASTM Committee C11 on Gypsum and Related Building Materials and Systems and is the direct responsibility of Subcommittee C11.03 on Specifications for the Application of Gypsum and Other Products in Assemblies.

Current edition approved April 15, 2012; August 15, 2012. Published May 2012. Originally approved in 1986. Last previous edition approved in 2011 as C1063-11b-C1063-12a. DOI: 10.1520/C1063-12A; 10.1520/C1063-12C.

² For referenced ASTM standards, visit the ASTM website, www.astm.org, or contact ASTM Customer Service at service@astm.org. For Annual Book of ASTM Standards volume information, refer to the standard's Document Summary page on the ASTM website.

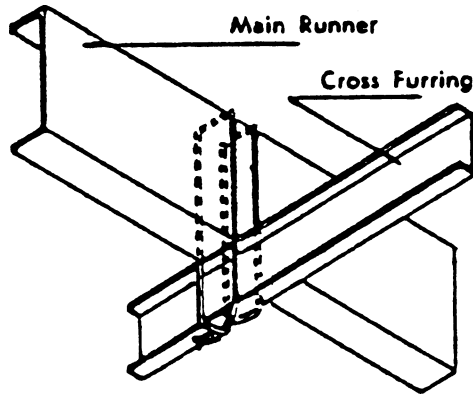

FIG. 2 Saddle Tie

6. Materials

6.1 Metal Plaster Bases:

- 6.1.1 Expanded Metal Lath—Specification C847, galvanized.
- 6.1.2 Wire Laths:
 - 6.1.2.1 Welded Wire Lath—Specification C933.
 - 6.1.2.2 Woven Wire Lath—Specification C1032.
 - 6.1.2.3 Paper Backed Plaster Bases—Specification C847.

6.2 Accessories:

6.2.1 General—All accessories shall have perforated or expanded flanges or clips shaped to permit complete embedment in the plaster, to provide means for accurate alignment, and to secure attachment of the accessory to the underlying surface. Accessories shall be designed to receive application of the specified plaster thickness.

6.2.2 Accessories shall be fabricated from Zinc Alloy (99 % pure zinc), galvanized (zinc coated) steel, rigid PVC or CPVC plastic, or anodized aluminum alloy. See Specification B221. (See Table 1 for minimum allowable thicknesses).

NOTE 2—The selection of an appropriate type of material for accessories shall be determined by applicable surrounding climatic and environmental conditions specific to the project location, such as salt air, industrial pollution, high moisture, or humidity.

6.2.3 Steel—Specification A653/A653M and shall have a G60 coating.

6.2.4 PVC Plastic—Specification D1784 or D4216.

6.2.5 Zinc Alloy—Specification B69, 99 % pure zinc.

6.2.6 Thickness of base material shall be as shown in Table 1.

6.2.7 Cornerite—1.75 lb/yd² (0.059 kg/m²), galvanized expanded metal lath, galvanized, 1.7 lb/yd² (0.057 kg/m²) galvanized woven or welded wire fabric of 0.0410 in. (1.04 mm) wire. When shaped for angle reinforcing, it shall have outstanding flanges (legs) of not less than 2 in. (51 mm).

6.3 Channels—Shall be cold-formed from steel with minimum 33 000 psi (228 MPa) yield strength and 0.0538 in. (1.37 mm) minimum bare steel thickness. Channel shall have a protective coating conforming to Specification A653/A653M–G60, or have a protective coating with an equivalent corrosion resistance for exterior applications, or shall be coated with a rust inhibitive paint, for interior applications, and shall have the following minimum weights in pounds per 1000 linear feet (kg/m).

Sizes, in. (mm)	Weight, lb/1000 ft (kg/m)	Flange Width, in. (mm)
¾ (19)	277 (0.412)	½ (13)
1½ (38)	414 (0.616)	½ (13)
2 (51)	506 (0.753)	½ (13)
2½ (64)	597 (0.888)	½ (13)

NOTE 3—Channels used in areas subject to corrosive action of salt air shall be hot-dipped galvanized, G60 coating.

TABLE 1 Minimum Thickness of Accessories

Accessory	Base Material, in. (mm)		
	Steel	Zinc Alloy	P.V.C.
Corner Beads	0.0172 (0.44)	0.0207 (0.53)	0.035 (0.89)
Casing Beads	0.0172 (0.44)	0.0207 (0.53)	0.035 (0.89)
Weep Screeds	0.0172 (0.44)	0.0207 (0.53)	0.050 (1.27)
Control Joints	0.0172 (0.44)	0.018 (0.46)	0.050 (1.27)

6.3.1 *External Corner Reinforcement*—Expanded lath, welded wire, or woven wire mesh bent to approximately 90° used to reinforce portland cement stucco at external corners. This accessory shall be fully embedded in the stucco.

6.3.2 *Weep Screed*—Accessory used to terminate portland cement based stucco at the bottom of exterior framed walls. This accessory shall have a sloped, solid, or perforated, ground or screed flange to facilitate the removal of moisture from the wall cavity and a vertical attachment flange not less than 3½ in. (89 mm) long.

6.4 *Wire*—As specified in Specification **A641/A641M** with a Class I zinc coated (galvanized), soft temper steel. Wire diameters (uncoated) specified herein correspond with United States Steel Wire Gauge numbers as follows:

Wire Gauge (US Steel Wire Gauge)	Diameter (in.)	mm
No. 20	0.0348	.88
No. 19	0.0410	1.04
No. 18	0.0475	1.21
No. 17	0.0540	1.37
No. 16	0.0625	1.59
No. 14	0.0800	2.03
No. 13	0.0915	2.32
No. 12	0.1055	2.68
No. 11	0.1205	3.06
No. 10	0.1350	3.43
No. 9	0.1483	3.77
No. 8	0.1620	4.12

6.5 *Rod and Strap Hangers*—Mild steel, zinc or cadmium plated, or protected with a rust-inhibiting paint.

6.6 *Clips*—Form from steel wire, Specification **A641/A641M** zinc-coated (galvanized), Specification **A641/A641M** or steel sheet, Specification **A653/A653M**, depending on use and manufacturer's requirements.

6.7 Fasteners:

6.7.1 *Nails*—For attaching metal plaster bases to wood supports, 0.1205-in. 11 gauge (3.06-mm) diameter, 7/16-in. (11.1-mm) head, barbed, galvanized roofing nails or galvanized common nails.

6.7.1.1 Nails for attaching metal plaster bases to solid substrates shall be not less than ¾ in. (19 mm) long.

6.7.2 Screws for attaching metal plaster base shall be fabricated in accordance with either Specification **C954** or **C1002** and shall have a 7/16 in. (11.1 mm) diameter pan wafer head and a 0.120 in. (3.0 mm) diameter shank. Screws used for attachment to metal framing members shall be self-drilling and self-tapping. Screws used for attachment to wood framing members shall be sharp-point.

7. Installation

7.1 *Workmanship*—Metal furring and lathing shall be erected so that the finished plaster surfaces are true to line (allowable tolerance of ¼ in. [6.4 mm] in 10 ft [3.05 m]), level, plumb, square, or curved as required to receive the specified plaster thickness.

7.2 Hangers and Inserts:

7.2.1 Hangers shall be of ample length and shall conform to the requirements of **Table 2** both as to size and maximum area to be supported, except as modified in this section.

7.2.2 When 1 by 3/16-in. (25 by 4.8-mm) flat inserts and hangers are used, 7/16-in. (11.1-mm) diameter holes shall be provided on the center line at the lower end of the insert and upper end of the hanger to permit the attachment of the hanger to the insert. The edge of the holes in both the inserts and the hangers shall be not less than 3/8 in. (9.5 mm) from the ends.

7.2.3 In concrete, hangers shall be attached to inserts embedded in the concrete or to other attachment devices designed for this purpose and able to develop full strength of the hanger.

7.2.4 Flat, steel hangers shall be bolted to 1 by 3/16-in. (25 by 4.8-mm) inserts with 3/8-in. (9.5-mm) diameter round-head stove bolts. (See **Fig. 3**.)

7.2.5 The nuts of the bolts shall be drawn up tight.

NOTE 4—Hangers required to withstand upward wind pressures shall be of a type to resist compression. Struts of formed channels shall be permitted.

7.3 *Installation of Hangers for Suspended Ceilings Under Wood Constructions*—Hangers shall be attached to supports by any of the following methods:

7.3.1 A hole shall be drilled through the wood member not less than 3 in. (76 mm) above the bottom with the upper end of the wire hanger passed through the hole and twisted three times around itself. See **Fig. 4**.

7.3.2 Three 12d nails shall be driven, on a downward slant, into the sides of the wood member with not less than 1¼ in. (31.8 mm) penetration and not less than 5 in. (127 mm) from the bottom edges, and not more than 36 in. (914 mm) on the center with the upper end of the wire hanger wrapped around the nails and twisted three times around itself. See **Fig. 5**.

7.3.3 A loop shall be formed in the upper end of the wire hanger and secured to the wood member by four 1½-in. (38.1-mm), not less than 9 gauge, 0.1483-in. (3.77-mm) diameter wire staples driven horizontally or on a downward slant into the sides of the wood members, three near the upper end of the loop and the fourth to fasten the loose end. See **Fig. 6**.

TABLE 2 Allowable Support or Hanger Wire Spacing ft-in. (mm) and Cold-Rolled Channel Main Runner Spans, ft-in. (mm)¹⁻¹⁰

NOTE 1—1 in. = 25.4 mm; 1 ft² = 0.093 m²

Member Size, in. (mm)	Member Weight, lb/1000 ft (kg/m)	Span Condition ^{9,10}	Uniform Load = 12 psf (0.479 kPa)				
			Member Spacing, in. (mm)				
			24 (610)	36 (914)	48 (1220)	60 (1520)	72 (1830)
			Allowable Hanger Wire or Support Spacing, ft-in. (mm)				
1½ (38.1)	414 (0.615)	Single	3-6 (1070)	3-1 (940)	2-9 (840)	2-9 (790)	2-5 (740)
		2 or More	4-11 (1500)	4-2 (1270)	3-7 (1090)	3-2 (970)	2-11 (890)
2 (50.8)	506 (0.753)	Single	3-9 (1140)	3-3 (990)	3-0 (910)	2-9 (840)	2-8 (810)
		2 or More	5-2 (1570)	4-6 (1370)	4-1 (1240)	3-10 (1170)	3-7 (1090)
2½ (63.5)	597 (0.888)	Single	3-11 (1190)	3-5 (1040)	3-2 (970)	2-11 (890)	2-9 (840)
		2 or More	5-5 (1650)	4-9 (1450)	4-4 (1320)	4-0 (1220)	3-10 (1170)

Member Size, in. (mm)	Member Weight, lb/1000 ft (kg/m)	Span Condition ^{9,10}	Uniform Load = 15 psf (0.287 kPa)				
			Member Spacing, in. (mm)				
			24 (610)	36 (914)	48 (1220)	60 (1520)	72 (1830)
1½ (38.1)	414 (0.616)	Single	3-3 (990)	2-10 (860)	2-7 (790)	2-4 (710)	2-2 (660)
		2 or More	4-6 (1370)	3-8 (1120)	3-2 (970)	2-10 (860)	2-7 (790)
2 (50.8)	506 (0.753)	Single	3-6 (1070)	3-1 (940)	2-10 (880)	2-7 (790)	2-5 (740)
		2 or More	4-10 (1470)	4-3 (1300)	3-10 (1170)	3-6 (1070)	3-3 (990)
2½ (63.5)	597 (0.888)	Single	3-8 (1120)	3-3 (990)	2-11 (890)	2-9 (840)	2-7 (790)
		2 or More	5-0 (1520)	4-5 (1350)	4-0 (1220)	3-9 (1140)	3-6 (1070)

Allowable Spans Notes:

- ¹ Bare metal thickness of cold-rolled main runners shall be not less than 0.0538 in. (1.367 mm).
- ² Inside corner radii shall not be greater than 1/8 in. (3.19 mm).
- ³ Spans based on upper flange of main runners laterally unbraced.
- ⁴ Maximum deflection limited to 1/360 of the span length.
- ⁵ Steel yield stress, Fy, shall be not less than 33 000 psi (228 MPa).
- ⁶ Uniform load 12 psf (dry density) shall be used for portland cement plaster ceilings with plaster thicknesses up to 7/8 in. (22 mm) and 15 psf shall be used for ceilings with plaster thicknesses over 7/8 in. (22 mm) and not more than 1-1/4 in. (32 mm).
- ⁷ "2 or More" spans refers to two or more continuous, equal spans.
- ⁸ For the "2 or More" span condition, listed spans represent the center-to-center distance between adjacent supports.
- ⁹ These tables are designed for dead loads. Specific conditions such as exterior installations in high wind areas require additional engineering.
- ¹⁰ Where uplift resistance is required for suspended ceilings to resist negative forces, the architect or engineer of record shall select the method to be used.

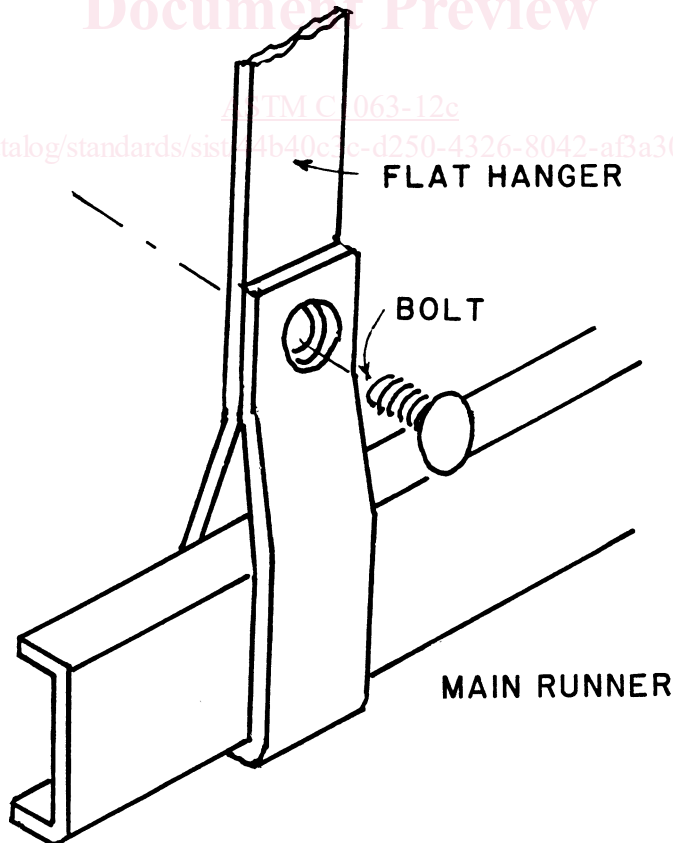

FIG. 3 Flat Hanger Attached to Main Runner Using Round-Head Stove Bolt

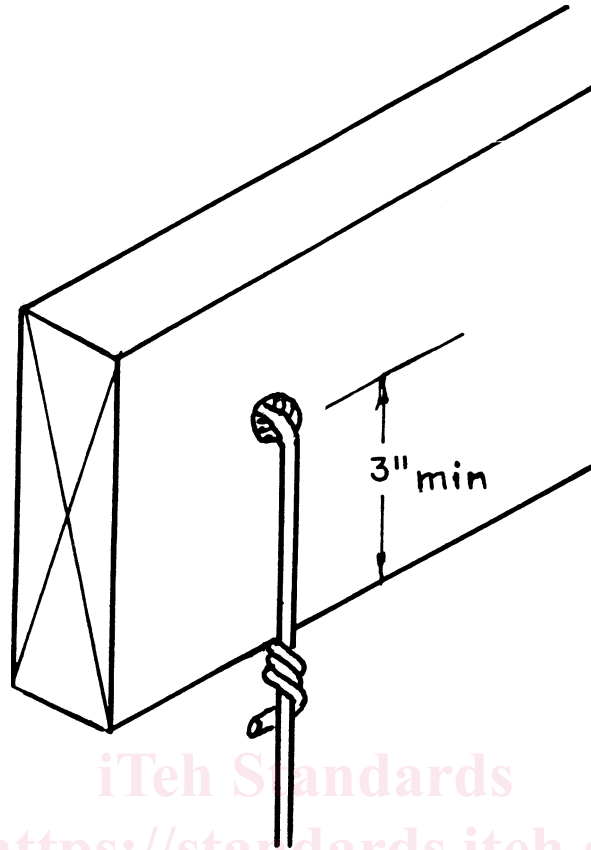

FIG. 4 Hanger Attached to Support Through a Drilled Hole

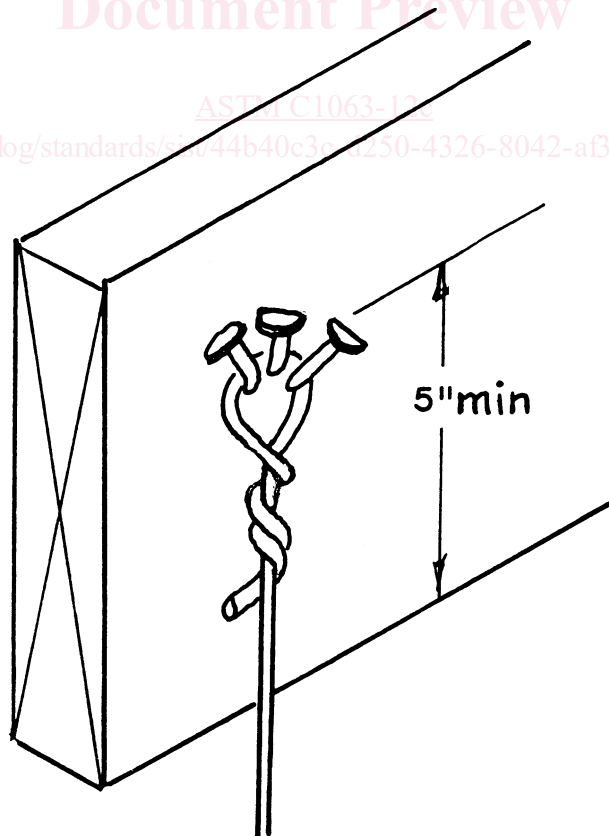

FIG. 5 Hanger Attached to Support Using Nails