



Designation: D2872 – 12

Standard Test Method for Effect of Heat and Air on a Moving Film of Asphalt (Rolling Thin-Film Oven Test)¹

This standard is issued under the fixed designation D2872; the number immediately following the designation indicates the year of original adoption or, in the case of revision, the year of last revision. A number in parentheses indicates the year of last reappraisal. A superscript epsilon (ϵ) indicates an editorial change since the last revision or reappraisal.

1. Scope

1.1 This test method is intended to measure the effect of heat and air on a moving film of semi-solid asphaltic materials. The effects of this treatment are determined from measurements of the selected properties of the asphalt before and after the test.

1.2 The values stated in inch-pound units are to be regarded as the standard.

1.3 *This standard does not purport to address all of the safety concerns, if any, associated with its use. It is the responsibility of the user of this standard to establish appropriate safety and health practices and determine the applicability of regulatory limitations prior to use.*

2. Referenced Documents

2.1 *ASTM Standards:*²

D113 Test Method for Ductility of Bituminous Materials

D2171 Test Method for Viscosity of Asphalts by Vacuum Capillary Viscometer

E1 Specification for ASTM Liquid-in-Glass Thermometers

E644 Test Methods for Testing Industrial Resistance Thermometers

E1137/E1137M Specification for Industrial Platinum Resistance Thermometers

3. Summary of Test Method

3.1 A moving film of asphaltic material is heated in an oven for 85 min at 325°F (163°C). The effects of heat and air are determined from changes in physical test values as measured before and after the oven treatment. An optional procedure is provided for determining the change in sample mass.

¹ This test method is under the jurisdiction of ASTM Committee D04 on Road and Paving Materials and is the direct responsibility of Subcommittee D04.46 on Durability and Distillation Tests.

Current edition approved Aug. 1, 2012. Published August 2012. Originally approved in 1970. Last previous edition approved in 2004 as D2872 – 04. DOI: 10.1520/D2872-12

² For referenced ASTM standards, visit the ASTM website, www.astm.org, or contact ASTM Customer Service at service@astm.org. For *Annual Book of ASTM Standards* volume information, refer to the standard's Document Summary page on the ASTM website.

3.2 Precision values for this test method have been developed for viscosity at 140°F (60°C); ductility at 60°F (15.6°C); and mass change.

4. Significance and Use

4.1 This test method indicates approximate change in properties of asphalt during conventional hot-mixing at about 302°F (150°C) as indicated by viscosity and other rheological measurements. It yields a residue which approximates the asphalt condition as incorporated in the pavement. If the mixing temperature differs appreciably from the 302°F (150°C) level, more or less effect on properties will occur. This test method also can be used to determine mass change, which is a measure of asphalt volatility.

5. Apparatus

5.1 *Oven*—This shall be a double-walled electrically heated convection-type oven. Its inside dimensions shall be 15 in. (381 mm) high, 19 in. (483 mm) wide (including the plenum), and 17½ ± ½ in. (445 ± 13 mm) deep (with the door closed). The door shall contain a symmetrically located window with dimensions of 12 to 13 in. (305 to 330 mm) wide by 8 to 9 in. (203 to 229 mm) high. The window shall contain two sheets of heat-resistant glass separated by an air space. The window should permit an unobstructed view of the interior of the oven. The top of the upper heating element shall be 1 ± ⅛ in. (25 ± 3 mm) below the oven floor.

5.1.1 The oven shall be vented at the top and bottom. The bottom vents shall be located symmetrically to supply incoming air around the heating elements. They shall have an open area of 2.31 ± 0.11 in.² (15.0 ± 0.7 cm²). The top vents shall be symmetrically arranged in the upper part of the oven and have an open area of 1.45 ± 0.07 in.² (9.3 ± 0.45 cm²).

5.1.2 The oven shall have an air plenum covering the side walls and ceiling. The air space shall be 1½ in. (38.1 mm) deep from the walls and ceiling. At a midpoint in the width of the oven, and 6 in. (152.4 mm) from the face of the circular metal carriage to its axis, a squirrel cage-type fan 5¼ in. (133 mm) OD by 2⅞ in. (73 mm) wide shall be turned at 1725 rpm by an externally mounted motor. The squirrel cage fan shall be set so that the fan turns in an opposite direction to its vanes. The air flow characteristics of the fan-plenum system shall be suction from the floor of the oven through the wall plenums and

exhaust of the air through the fan. Fig. 1 and Fig. 2 show details of this plenum system.

5.1.3 The oven shall be equipped with a proportional control thermostat capable of maintaining a temperature of 325°F (163°C) to within ±1.0°F (±0.5°C). The sensing element of the thermostat may be placed at any location that enables the oven to maintain temperature control as specified by this standard.

5.1.4 The thermometer shall be hung or affixed to a mounting in the ceiling which is 2 in. (50.8 mm) from the right side of the oven at a midpoint in the depth of the oven. The thermometer shall hang down into the oven so that the bulb of the thermometer is within 1 in. of an imaginary line level with the shaft of the circular metal carriage. The heating controls shall be capable of bringing the fully loaded oven back to the test temperature within a 10-min period after insertion of the samples in a preheated oven.

5.1.5 The oven shall be provided with a 12-in. (304.8-mm) diameter, vertical circular carriage (see Fig. 2 for details). This carriage shall be provided with suitable openings and clips for

firmly holding eight glass containers in a horizontal position (see Fig. 3). The vertical carriage shall be mechanically driven through a 3/4-in. (19-mm) diameter shaft at a speed of 15 ± 0.2 r/min.

5.1.6 The oven shall be equipped with an air jet positioned to blow heated air into each bottle at its lowest point of travel. The air jet shall have an outlet orifice 0.04 in. (1.016 mm) in diameter (No. 60 drill) connected to a 25-ft (7.6-m) length of 5/16-in. (8-mm) outside diameter refrigeration copper tubing. This tubing shall be coiled to lie flat on the bottom of the oven and lead to a source of fresh, dried, dust-free regulated air.

NOTE 1—Activated silica gel treated with an indicator is a satisfactory desiccant for the dried air.

5.2 Flowmeter—The flowmeter may be any suitable type capable of accurately measuring the airflow at a rate of 4000 mL/min. The flowmeter shall be located downstream of all regulating devices and upstream of the copper coil. The flowmeter shall be positioned so it is maintained at approximately room temperature. The airflow shall be calibrated

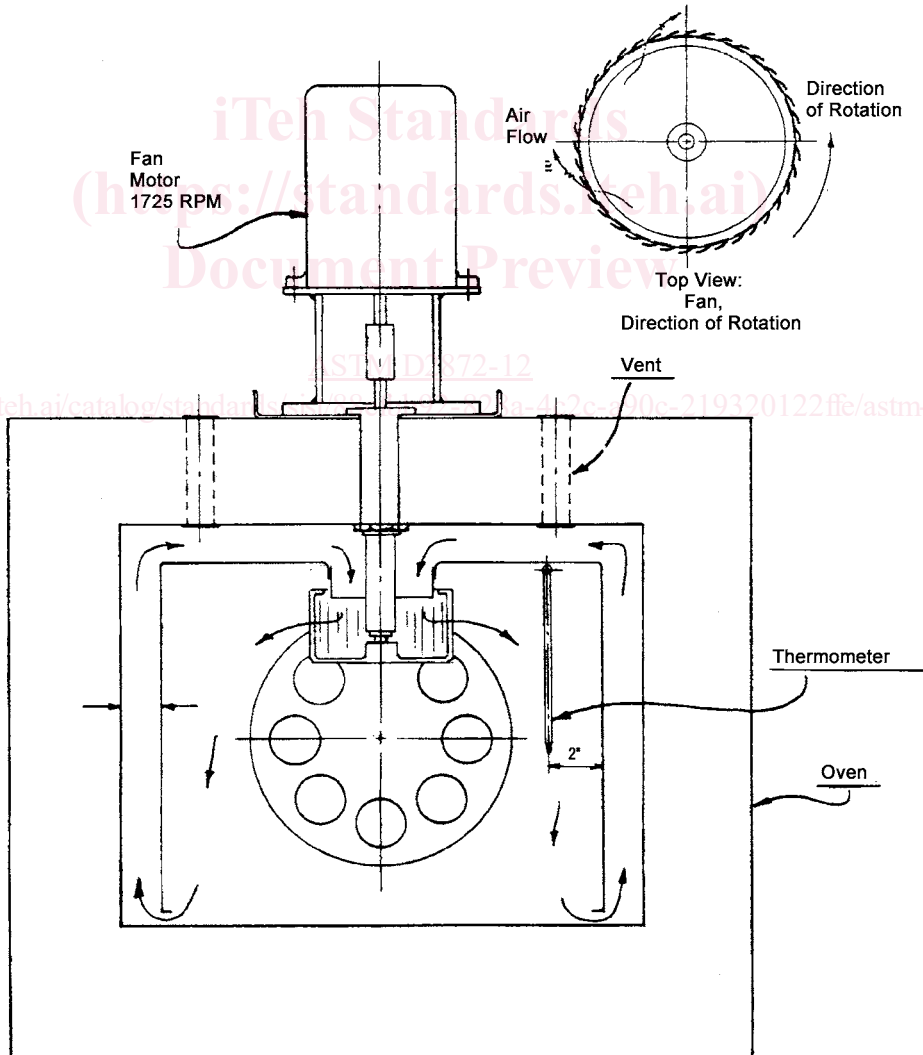

FIG. 1 Schematic of Air Flow Front View

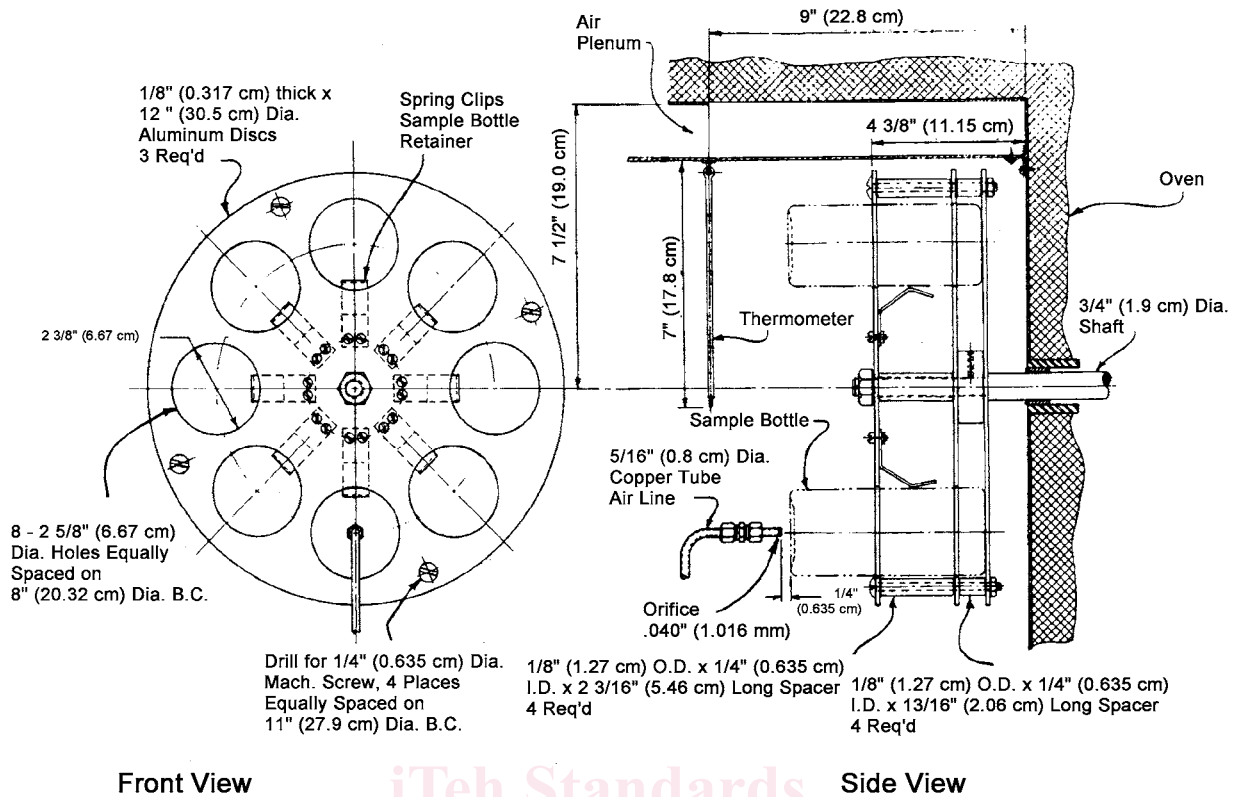

FIG. 2 Circular Metal Carriage

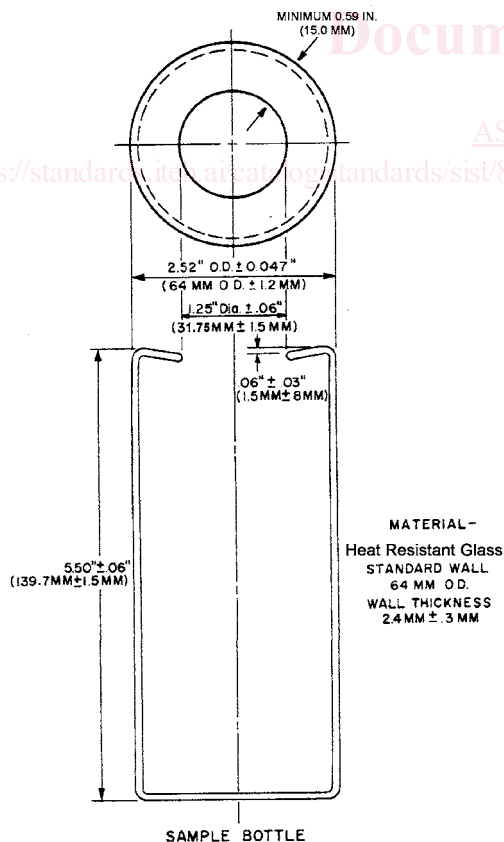

FIG. 3 Sample Bottle

periodically using a wet-test meter or other displacement method. This calibration shall be based on airflow exiting the air jet and shall be conducted with the oven off and at room temperature.

5.3 *Thermometer*—This shall be an ASTM Thermometer conforming to the requirements for Thermometer 13C as prescribed in Specification E1. This thermometer shall be used to make all temperature measurements required by this test method. In order to reduce the risks associated with thermometer breakage, the thermometer may be fully or partially encapsulated in an optically transparent polymer sheath having a maximum thickness of 0.01 in. (0.25 mm). If a sheath is used, it shall be installed such that there is substantial mechanical contact with the thermometer. The thermometer shall be recalibrated after installation of a sheath.

5.3.1 The test thermometer may be replaced with an electronic temperature measurement system, provided the following requirements are met:

5.3.1.1 The electronic temperature sensor shall be a 3 or 4 wire, Grade A Platinum Resistance Thermometer (PRT) substantially conforming to the requirements of Specification E1137/E1137M. The temperature sensor shall be mounted in the same position and orientation as the test thermometer it replaces.

5.3.1.2 The electronic sensor shall have a thermal response time that differs by no more than 30% from the thermal response time of the designated test thermometer. Thermal response shall be defined as the time required to achieve a 95% response to a temperature step change, starting in air at ambient