

ISO/TC 59/SC 8

Secretariat: SAC

Voting begins on:  
2021-07-22

Voting terminates on:  
2021-09-16

---

---

## Building and civil engineering sealants — Determination of adhesion/cohesion properties of sealants after immersion in water

*Mastics pour bâtiments et ouvrages de génie civil — Détermination  
des propriétés d'adhésivité/cohésion des mastics après immersion  
dans l'eau*

iTeh STANDARD PREVIEW  
(standards.iteh.ai)

[ISO/FDIS 10591](https://standards.iteh.ai/catalog/standards/sist/14e2a7d1-f8d5-44f2-83f6-ff1e163597f2/iso-fdis-10591)

<https://standards.iteh.ai/catalog/standards/sist/14e2a7d1-f8d5-44f2-83f6-ff1e163597f2/iso-fdis-10591>

RECIPIENTS OF THIS DRAFT ARE INVITED TO SUBMIT, WITH THEIR COMMENTS, NOTIFICATION OF ANY RELEVANT PATENT RIGHTS OF WHICH THEY ARE AWARE AND TO PROVIDE SUPPORTING DOCUMENTATION.

IN ADDITION TO THEIR EVALUATION AS BEING ACCEPTABLE FOR INDUSTRIAL, TECHNOLOGICAL, COMMERCIAL AND USER PURPOSES, DRAFT INTERNATIONAL STANDARDS MAY ON OCCASION HAVE TO BE CONSIDERED IN THE LIGHT OF THEIR POTENTIAL TO BECOME STANDARDS TO WHICH REFERENCE MAY BE MADE IN NATIONAL REGULATIONS.

ISO/CEN PARALLEL PROCESSING



Reference number  
ISO/FDIS 10591:2021(E)

**iTeh STANDARD PREVIEW**  
**(standards.iteh.ai)**

ISO/FDIS 10591

<https://standards.iteh.ai/catalog/standards/sist/14e2a7d1-f8d5-44f2-83f6-ff1e163597f2/iso-fdis-10591>



**COPYRIGHT PROTECTED DOCUMENT**

© ISO 2021

All rights reserved. Unless otherwise specified, or required in the context of its implementation, no part of this publication may be reproduced or utilized otherwise in any form or by any means, electronic or mechanical, including photocopying, or posting on the internet or an intranet, without prior written permission. Permission can be requested from either ISO at the address below or ISO's member body in the country of the requester.

ISO copyright office  
CP 401 • Ch. de Blandonnet 8  
CH-1214 Vernier, Geneva  
Phone: +41 22 749 01 11  
Email: [copyright@iso.org](mailto:copyright@iso.org)  
Website: [www.iso.org](http://www.iso.org)

Published in Switzerland

# Contents

	Page
Foreword .....	iv
<b>1 Scope .....</b>	<b>1</b>
<b>2 Normative references .....</b>	<b>1</b>
<b>3 Terms and definitions .....</b>	<b>1</b>
<b>4 Principle .....</b>	<b>1</b>
<b>5 Apparatus .....</b>	<b>1</b>
<b>6 Preparation of test specimens .....</b>	<b>3</b>
<b>7 Conditioning of test specimens .....</b>	<b>4</b>
7.1 General .....	4
7.2 Conditioning method A .....	4
7.3 Conditioning method B .....	4
<b>8 Test procedure .....</b>	<b>4</b>
<b>9 Expression of results .....</b>	<b>4</b>
<b>10 Test report .....</b>	<b>5</b>

## iTeh STANDARD PREVIEW (standards.iteh.ai)

[ISO/FDIS 10591](https://standards.iteh.ai/catalog/standards/sist/14e2a7d1-f8d5-44f2-83f6-ff1e163597f2/iso-fdis-10591)

<https://standards.iteh.ai/catalog/standards/sist/14e2a7d1-f8d5-44f2-83f6-ff1e163597f2/iso-fdis-10591>

## Foreword

ISO (the International Organization for Standardization) is a worldwide federation of national standards bodies (ISO member bodies). The work of preparing International Standards is normally carried out through ISO technical committees. Each member body interested in a subject for which a technical committee has been established has the right to be represented on that committee. International organizations, governmental and non-governmental, in liaison with ISO, also take part in the work. ISO collaborates closely with the International Electrotechnical Commission (IEC) on all matters of electrotechnical standardization.

The procedures used to develop this document and those intended for its further maintenance are described in the ISO/IEC Directives, Part 1. In particular, the different approval criteria needed for the different types of ISO documents should be noted. This document was drafted in accordance with the editorial rules of the ISO/IEC Directives, Part 2 (see [www.iso.org/directives](http://www.iso.org/directives)).

Attention is drawn to the possibility that some of the elements of this document may be the subject of patent rights. ISO shall not be held responsible for identifying any or all such patent rights. Details of any patent rights identified during the development of the document will be in the Introduction and/or on the ISO list of patent declarations received (see [www.iso.org/patents](http://www.iso.org/patents)).

Any trade name used in this document is information given for the convenience of users and does not constitute an endorsement.

For an explanation of the voluntary nature of standards, the meaning of ISO specific terms and expressions related to conformity assessment, as well as information about ISO's adherence to the World Trade Organization (WTO) principles in the Technical Barriers to Trade (TBT), see [www.iso.org/iso/foreword.html](http://www.iso.org/iso/foreword.html).

This document was prepared by Technical Committee ISO/TC 59, *Buildings and civil engineering works*, Subcommittee SC 8, *Sealant*, in collaboration with the European Committee for Standardization (CEN) Technical Committee CEN/SS B02, *Structures*, in accordance with the Agreement on technical cooperation between ISO and CEN (Vienna Agreement).

This 3<sup>rd</sup> edition cancels and replaces the 2<sup>nd</sup> edition (ISO 10591:2005), which has been technically revised.

The main changes compared to the previous edition are as follows:

- the title of the document has been modified;
- the range of variation of extension rate has been changed to  $(5,5 \pm 0,5)$  mm/min;
- the range of variation of relative humidity has been changed to  $(50 \pm 10)$  %;
- the operation sequence for the cleaning substrate materials has been added;
- the expression of results has been improved by showing a formula with descriptors.

Any feedback or questions on this document should be directed to the user's national standards body. A complete listing of these bodies can be found at [www.iso.org/members.html](http://www.iso.org/members.html).

# Building and civil engineering sealants — Determination of adhesion/cohesion properties of sealants after immersion in water

## 1 Scope

This document specifies a method for the determination of the influence of water on the adhesion/cohesion properties of sealants with predominantly plastic behaviour which are used in joints in buildings and civil engineering works.

## 2 Normative references

The following documents are referred to in the text in such a way that some or all of their content constitutes requirements of this document. For dated references, only the edition cited applies. For undated references, the latest edition of the referenced document (including any amendments) applies.

ISO 6927, *Building and civil engineering sealants — Vocabulary*

ISO 13640, *Buildings and civil engineering works — Sealants — Specifications for test substrates*

## 3 Terms and definitions (standards.iteh.ai)

For the purposes of this document, the terms and definitions given in ISO 6927 apply.

ISO and IEC maintain terminology databases for use in standardization at the following addresses:

- ISO Online browsing platform: available at <https://www.iso.org/obp>
- IEC Electropedia: available at <https://www.electropedia.org/>

## 4 Principle

Test specimens are prepared in which the sealant to be tested adheres to two parallel contact surfaces. After submission of the test specimens to water immersion under defined conditions, the test specimens are extended to rupture and the elongation at break recorded.

## 5 Apparatus

**5.1 Substrate material**, used for the preparation of test specimens, which shall be as defined in ISO 13640. The materials shall be selected from mortar and/or anodized aluminium and/or glass. Other substrate materials may be used as agreed by the parties concerned.

For each test specimen, two substrate pieces of the same material are required, with a cross-section of dimensions as shown in [Figures 1](#) and [2](#). Test substrates of other dimensions may be used, but then the dimensions of the sealant bead and the area of adhesion shall be the same as those shown in [Figures 1](#) and [2](#).

**5.2 Spacers**, for the preparation of the test specimens, of cross-section (12 mm × 12 mm) with anti-adherent surface (see [Figures 1](#) and [2](#)).

5.3 **Anti-adherent substrate**, for the preparation of test specimens, e.g. polyethylene (PE) film, preferably according to the advice of the sealant manufacturer.

5.4 **Ventilated convection-type oven**, capable of being maintained at  $(70 \pm 2) \text{ }^\circ\text{C}$  (conditioning method B).

5.5 **Container A**, for distilled water or water immersion at  $(23 \pm 2) \text{ }^\circ\text{C}$  (conditioning method B).

5.6 **Container B**, for water immersion of test specimens at  $(23 \pm 2) \text{ }^\circ\text{C}$ .

5.7 **Test machine**, capable of extending the test specimens at a rate of  $(5,5 \pm 0,5) \text{ mm/min}$ .

Dimensions in millimetres

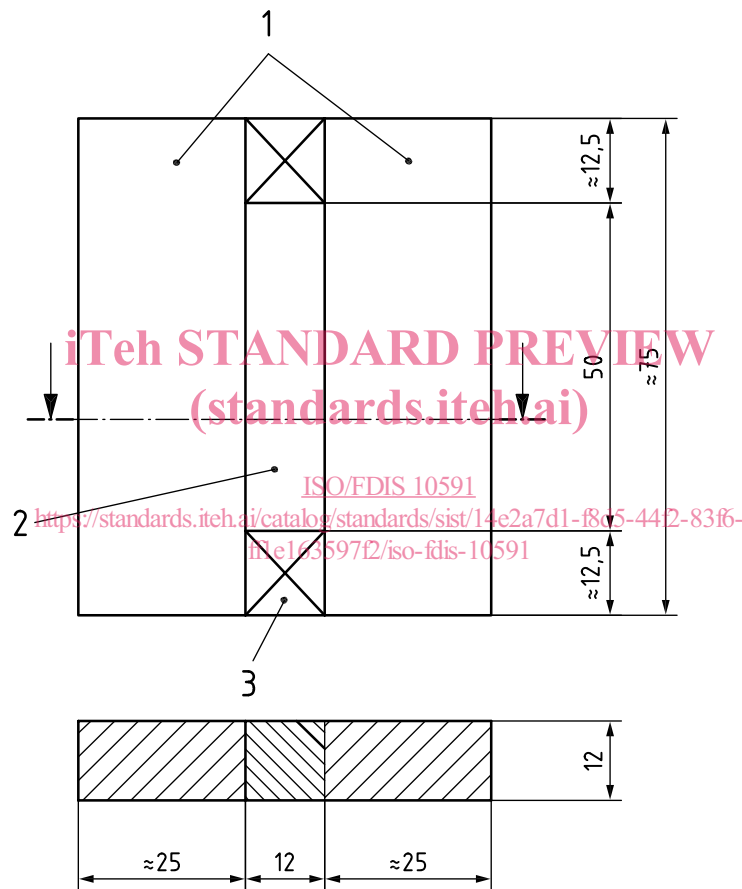

**Key**

- 1 mortar substrates
- 2 sealant
- 3 spacer

**Figure 1 — Test specimen with mortar substrates**

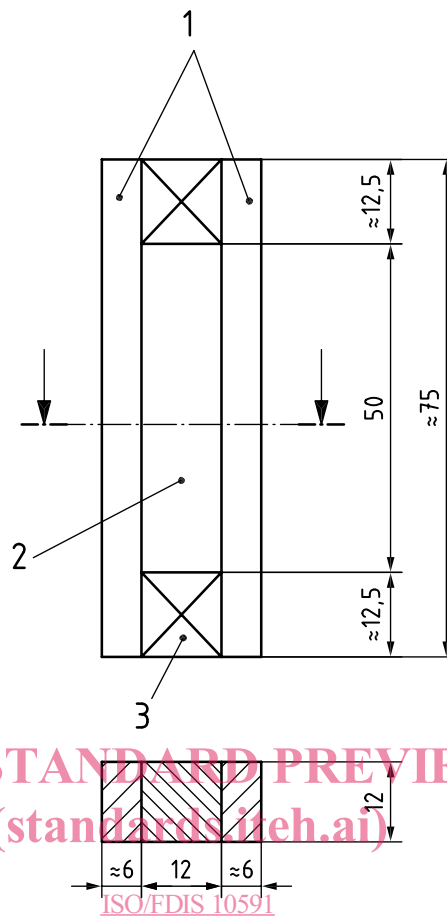
**Key**

- 1 aluminium or glass substrates  
 2 sealant  
 3 spacer

<https://standards.iteh.ai/catalog/standards/sist/14e2a7d1-f8d5-44f2-83f6-ff1e163597f2/iso-fdis-10591>

**Figure 2 — Test specimen with anodized aluminium or glass substrates**

## 6 Preparation of test specimens

The sealant and the substrate shall be brought to  $(23 \pm 2)$  °C. For each substrate material, three test specimens shall be prepared. For each test specimen, two substrates (5.1) and two spacers (5.2) shall be assembled (see Figures 1 and 2) and set on the anti-adherent substrate (5.3).

Remove the ash floating on the surface of cement substrate by absorbent gauze and clean the aluminium and glass plates with acetone and other solvents.

The instructions of the sealant manufacturer shall be followed concerning, for instance, whether a primer is to be used and the mixing procedure for multi-component sealants. The hollow volume formed by the substrates shall be filled with the sealant.

The following precautions shall be taken:

- the formation of air bubbles shall be avoided;
- the sealant shall be pressed to the contact surfaces of the substrates;
- the sealant surface shall be trimmed so that it is flush with the faces of the substrates and the spacers.

The specimens shall be set on the edge of one of the substrates. The anti-adherent substrate shall be removed as soon as possible. The specimens shall be kept in this position to allow curing or optimum drying of the sealant.

The spacers shall be maintained in place during conditioning.

## 7 Conditioning of test specimens

### 7.1 General

The test specimens shall be conditioned either in accordance with method A (7.2) or method B (7.3), as agreed between the parties concerned.

### 7.2 Conditioning method A

The test specimens shall be conditioned for 28 days at  $(23 \pm 2) ^\circ\text{C}$  and  $(50 \pm 10) \%$  relative humidity.

### 7.3 Conditioning method B

The test specimens shall be conditioned according to method A and shall then be subjected three times to the following storage cycle:

- a) three days in the oven (5.4) at  $(70 \pm 2) ^\circ\text{C}$ ;
- b) one day in distilled water (5.5) at  $(23 \pm 2) ^\circ\text{C}$ ;
- c) two days in the oven (5.4) at  $(70 \pm 2) ^\circ\text{C}$ ;
- d) one day in distilled water (5.5) at  $(23 \pm 2) ^\circ\text{C}$ .

Alternatively, this cycle may be carried out in the order c), d), a), b).

After conditioning according to method B, the test specimens shall be stored for 24 h at  $(23 \pm 2) ^\circ\text{C}$  and  $(50 \pm 10) \%$  relative humidity before testing.

NOTE Method B is a commonly used conditioning procedure using the influence of heat and water. It is not suitable for giving information on the durability of the sealant.

## 8 Test procedure

After conditioning according to method A or method B, the spacers shall be removed. The test specimens shall be immersed for four days in water at a temperature of  $(23 \pm 2) ^\circ\text{C}$  (5.6) and stored one day in air at  $(23 \pm 2) ^\circ\text{C}$  and  $(50 \pm 10) \%$  relative humidity. The test specimens shall be placed in the tensile test machine (5.7) and extended at a rate of  $(5,5 \pm 0,5) \text{ mm/min}$  until break. The force/extension diagram shall be recorded.

## 9 Expression of results

For each test specimen, the arithmetic mean of the three elongations to break shall be calculated and rounded to 5 %. See the follow formula:

$$E = \frac{W_1 - W_0}{W_0} \times 100 \%$$

Where



$E$  is the elongation, in %;

$W_0$  is the original width, in mm;

$W_1$  is the final width, in mm.

## 10 Test report

The test report shall contain the following information:

- a) test laboratory's name and date of testing;
- b) reference to this document;
- c) name, type (chemical family) and colour of sealant., for multi-component, add the proportion;
- d) batch of sealant from which the test specimens were produced;
- e) the substrate materials used (see 5.1);
- f) the primer(s) used, if applicable;
- g) the conditioning method used;
- h) force/extension diagrams of the test specimens;
- i) the percentage elongation at break of each test specimen;
- j) the arithmetic mean of the three elongations at break;
- k) type of failure (adhesive or cohesive or mixed);
- l) any deviation from this document.

iTeh STANDARD PREVIEW  
(standards.iteh.ai)

ISO/FDIS 10591

<https://standards.iteh.ai/catalog/standards/sist/14e2a7d1-f8d5-44f2-83f6-f1e163597f2/iso-fdis-10591>

**iTeh STANDARD PREVIEW**  
**(standards.iteh.ai)**

ISO/FDIS 10591

<https://standards.iteh.ai/catalog/standards/sist/14e2a7d1-f8d5-44f2-83f6-ff1e163597f2/iso-fdis-10591>