

ISO/TC 195/SC 1

Secretariat: JISC

Voting begins on:
2022-11-21

Voting terminates on:
2023-01-16

Building construction machinery and equipment — Self-loading mobile concrete mixers — Safety requirements and verification

*Machines et matériels pour la construction des bâtiments —
Malaxeurs à béton mobiles avec autochargeur — Exigences de
sécurité et vérification*

iTeh STANDARD PREVIEW
(standards.iteh.ai)

ISO/FDIS 6085

<https://standards.iteh.ai/catalog/standards/sist/4addf4e8-f076-4bed-8d25-a6b1b91f401c/iso-fdis-6085>

RECIPIENTS OF THIS DRAFT ARE INVITED TO SUBMIT, WITH THEIR COMMENTS, NOTIFICATION OF ANY RELEVANT PATENT RIGHTS OF WHICH THEY ARE AWARE AND TO PROVIDE SUPPORTING DOCUMENTATION.

IN ADDITION TO THEIR EVALUATION AS BEING ACCEPTABLE FOR INDUSTRIAL, TECHNOLOGICAL, COMMERCIAL AND USER PURPOSES, DRAFT INTERNATIONAL STANDARDS MAY ON OCCASION HAVE TO BE CONSIDERED IN THE LIGHT OF THEIR POTENTIAL TO BECOME STANDARDS TO WHICH REFERENCE MAY BE MADE IN NATIONAL REGULATIONS.



Reference number
ISO/FDIS 6085:2022(E)

iTeh STANDARD PREVIEW
(standards.iteh.ai)

ISO/FDIS 6085

<https://standards.iteh.ai/catalog/standards/sist/4addf4e8-f076-4bed-8d25-a6b1b91f401c/iso-fdis-6085>



COPYRIGHT PROTECTED DOCUMENT

© ISO 2022

All rights reserved. Unless otherwise specified, or required in the context of its implementation, no part of this publication may be reproduced or utilized otherwise in any form or by any means, electronic or mechanical, including photocopying, or posting on the internet or an intranet, without prior written permission. Permission can be requested from either ISO at the address below or ISO's member body in the country of the requester.

ISO copyright office
CP 401 • Ch. de Blandonnet 8
CH-1214 Vernier, Geneva
Phone: +41 22 749 01 11
Email: copyright@iso.org
Website: www.iso.org

Published in Switzerland

Contents

	Page
Foreword.....	v
Introduction.....	vi
1 Scope.....	1
2 Normative references.....	1
3 Terms and definitions.....	4
4 Safety requirements, protective measures and risk reduction.....	4
4.1 General.....	4
4.2 Access systems.....	4
4.2.1 General requirements.....	4
4.2.2 Access to articulated machines.....	4
4.3 Operator's station.....	5
4.3.1 General requirements.....	5
4.3.2 Operator's station equipped with a cab.....	6
4.3.3 Operator-protective structures.....	7
4.4 Operator's seat.....	8
4.4.1 General requirements.....	8
4.4.2 Dimensions.....	8
4.4.3 Adjustment.....	8
4.4.4 Vibration.....	8
4.4.5 Restraint system.....	8
4.5 Operator's controls and indicators.....	8
4.5.1 General.....	8
4.5.2 Starting and stopping system.....	8
4.5.3 Inadvertent activation.....	8
4.5.4 Pedals.....	9
4.5.5 Emergency loading equipment lowering.....	9
4.5.6 Uncontrolled motion.....	9
4.5.7 Multiple operating positions.....	9
4.5.8 Visual displays, control panels, indicators and symbols.....	9
4.6 Steering systems.....	10
4.6.1 General.....	10
4.6.2 Wheeled machines.....	10
4.7 Brake systems.....	10
4.8 Visibility.....	10
4.8.1 Operator's field of view.....	10
4.8.2 Lighting, signalling and marking lights, and reflex-reflector devices.....	11
4.9 Warning devices and safety signs.....	11
4.10 Tyres and rims.....	11
4.11 Stability.....	11
4.12 Noise.....	12
4.12.1 Requirements for noise reduction.....	12
4.12.2 Noise emission measurement.....	12
4.13 Protective measures and devices.....	12
4.13.1 Hot parts.....	12
4.13.2 Moving parts.....	12
4.13.3 Guards.....	13
4.13.4 Articulated frame lock.....	13
4.13.5 Sharp edges and acute angles.....	13
4.13.6 Fenders.....	13
4.14 Retrieval, transportation, lifting and towing.....	13
4.14.1 Common use.....	13
4.14.2 Retrieval.....	13
4.14.3 Tying-down.....	13

4.14.4	Lifting.....	13
4.14.5	Off-road towing.....	13
4.14.6	Transportation.....	14
4.15	Electrical and electronic systems.....	14
4.15.1	General.....	14
4.15.2	Degree of protection.....	14
4.15.3	Electrical connections.....	14
4.15.4	Over-current protective devices.....	14
4.15.5	Batteries.....	15
4.15.6	Battery disconnection.....	15
4.15.7	Electrical connectors for auxiliary starting aids.....	15
4.15.8	Electric sockets for lighting.....	15
4.16	Pressurized systems.....	15
4.16.1	General requirements.....	15
4.16.2	Hydraulic lines.....	15
4.16.3	Hydraulic hose assemblies.....	16
4.16.4	Air pressure vessels.....	16
4.17	Fuel tanks and hydraulic oil tanks.....	16
4.17.1	General requirements.....	16
4.17.2	Filler openings.....	16
4.17.3	Fuel tanks.....	16
4.18	Fire protection.....	16
4.18.1	Fire resistance.....	16
4.18.2	Fire extinguisher.....	16
4.19	Rotating drum and related equipment.....	17
4.19.1	General.....	17
4.19.2	Rollers.....	17
4.19.3	Loading equipment.....	17
4.19.4	Discharging chute.....	17
4.19.5	Cleaning system.....	18
4.20	Maintenance.....	18
4.20.1	General.....	18
4.20.2	Routine maintenance.....	18
4.20.3	Support devices.....	18
4.20.4	Access to the engine compartment.....	19
4.21	Underground operation in non-explosive atmospheres.....	19
4.21.1	General.....	19
4.21.2	Lighting, signalling and marking lights, and reflex-reflector devices.....	19
4.21.3	Engine exhaust emission and fuel.....	19
5	Verification of safety requirements.....	19
6	Information for use.....	20
6.1	General.....	20
6.2	Safety labels.....	20
6.3	Operator's manual.....	20
6.4	Machine marking.....	20
Bibliography.....		22

Foreword

ISO (the International Organization for Standardization) is a worldwide federation of national standards bodies (ISO member bodies). The work of preparing International Standards is normally carried out through ISO technical committees. Each member body interested in a subject for which a technical committee has been established has the right to be represented on that committee. International organizations, governmental and non-governmental, in liaison with ISO, also take part in the work. ISO collaborates closely with the International Electrotechnical Commission (IEC) on all matters of electrotechnical standardization.

The procedures used to develop this document and those intended for its further maintenance are described in the ISO/IEC Directives, Part 1. In particular, the different approval criteria needed for the different types of ISO documents should be noted. This document was drafted in accordance with the editorial rules of the ISO/IEC Directives, Part 2 (see www.iso.org/directives).

Attention is drawn to the possibility that some of the elements of this document may be the subject of patent rights. ISO shall not be held responsible for identifying any or all such patent rights. Details of any patent rights identified during the development of the document will be in the Introduction and/or on the ISO list of patent declarations received (see www.iso.org/patents).

Any trade name used in this document is information given for the convenience of users and does not constitute an endorsement.

For an explanation of the voluntary nature of standards, the meaning of ISO specific terms and expressions related to conformity assessment, as well as information about ISO's adherence to the World Trade Organization (WTO) principles in the Technical Barriers to Trade (TBT), see www.iso.org/iso/foreword.html.

This document was prepared by Technical Committee ISO/TC 195, *Building construction machinery and equipment*, Subcommittee SC 1, *Machinery and equipment for concrete work*.

Any feedback or questions on this document should be directed to the user's national standards body. A complete listing of these bodies can be found at www.iso.org/members.html.

Introduction

This document is a type-C standard as stated in ISO 12100.

This document is of relevance, in particular, for the following stakeholder groups representing the market players with regard to machinery safety:

- machine manufacturers (small, medium and large enterprises);
- health and safety bodies (regulators, accident prevention organizations, market surveillance, etc.).

Others can be affected by the level of machinery safety achieved with the means of the document by the above-mentioned stakeholder groups:

- machine users/employers (small, medium and large enterprises);
- machine users/employees (e.g. trade unions, organizations for people with special needs);
- service providers, e.g. for maintenance (small, medium and large enterprises);
- consumers (in the case of machinery intended for use by consumers).

The above-mentioned stakeholder groups have been given the possibility to participate at the drafting process of this document.

The machinery concerned and the extent to which hazards, hazardous situations or hazardous events are covered are indicated in the Scope of this document.

When requirements of this type-C standard are different from those which are stated in type-A or -B standards, the requirements of this type-C standard take precedence over the requirements of the other standards for machines that have been designed and built according to the requirements of this type-C standard.

[ISO/FDIS 6085](https://standards.iteh.ai/catalog/standards/sist/4addf4e8-f076-4bed-8d25-a6b1b91f401c/iso-fdis-6085)

<https://standards.iteh.ai/catalog/standards/sist/4addf4e8-f076-4bed-8d25-a6b1b91f401c/iso-fdis-6085>

Building construction machinery and equipment — Self-loading mobile concrete mixers — Safety requirements and verification

1 Scope

This document specifies general safety requirements for self-loading mobile concrete mixers (hereafter referred to as “machines”) as defined in ISO 18650-1:2021, with rigid or articulated wheeled chassis.

This document applies to machines which are designed for front or rear loading and are provided with a swinging frame where the rotating drum and the self-loading equipment (lift arms and bucket) are mounted on. Machines are also fitted with accessories such as water dosing means and a weighing system.

This document deals with all significant hazards, hazardous situations and events relevant to the machine when used as intended or under conditions of misuse reasonably foreseeable by the manufacturer.

This document is not applicable to the following:

- a) machines designed primarily for earth moving, such as loaders or dumpers (see applicable parts of the ISO 20474 series);
- b) truck mixers.

This document does not address hazards that can occur:

- during manufacture;
- when using machines on public roads, where specific local road regulations can apply;
- when operating in potentially explosive atmospheres.

This document is not applicable to machines manufactured before the date of its publication.

2 Normative references

The following documents are referred to in the text in such a way that some or all of their content constitutes requirements of this document. For dated references, only the edition cited applies. For undated references, the latest edition of the referenced document (including any amendments) applies.

ISO 12100:2010, *Safety of machinery — General principles for design — Risk assessment and risk reduction*

ISO 2867:2011, *Earth-moving machinery — Access systems*

ISO 3411:2007, *Earth-moving machinery — Physical dimensions of operators and minimum operator space envelope*

ISO 6682:1986, *Earth-moving machinery — Zones of comfort and reach for controls*

ISO 6682:1986/Amd 1:1989, *Earth-moving machinery — Zones of comfort and reach for controls — Amendment 1*

ISO 12508:1994, *Earth-moving machinery — Operator station and maintenance areas — Bluntness of edges*

ISO/FDIS 6085:2022(E)

- ISO 10263-3:2009, *Earth-moving machinery — Operator enclosure environment — Part 3: Pressurization test method*
- ISO 10263-4:2009, *Earth-moving machinery — Operator enclosure environment — Part 4: Heating, ventilating and air conditioning (HVAC) test method and performance*
- ISO 3471:2008, *Earth-moving machinery — Roll-over protective structures — Laboratory tests and performance requirements*
- ISO 3164:2013, *Earth-moving machinery — Laboratory evaluations of protective structures — Specifications for deflection-limiting volume*
- ISO 3449:2005, *Earth-moving machinery — Falling-object protective structures — Laboratory tests and performance requirements*
- ISO 11112:1995, *Earth-moving machinery — Operator's seat — Dimensions and requirements*
- ISO 11112:1995/Amd 1:2001, *Earth-moving machinery — Operator's seat — Dimensions and requirements — Amendment 1*
- ISO 7096:2020, *Earth-moving machinery — Laboratory evaluation of operator seat vibration*
- ISO 6683:2005, *Earth-moving machinery — Seat belts and seat belt anchorages — Performance requirements and tests*
- ISO 3776-1:2006, *Tractors and machinery for agriculture — Seat belts — Part 1: Anchorage location requirements*
- ISO 3776-2:2013, *Tractors and machinery for agriculture — Seat belts — Part 2: Anchorage strength requirements*
- ISO 3776-3:2009, *Tractors and machinery for agriculture — Seat belts — Part 3: Requirements for assemblies*
- <https://standards.iteh.ai/catalog/standards/sist/4addf4e8-f076-4bed-8d25-a6b1b91f401c/iso-10968:2020>, *Earth-moving machinery — Operator's controls*
- ISO 10264:1990, *Earth-moving machinery — Key-locked starting systems*
- ISO 13850:2015, *Safety of machinery — Emergency stop function — Principles for design*
- ISO 15817:2012, *Earth-moving machinery — Safety requirements for remote operator control systems*
- ISO 6011:2003, *Earth-moving machinery — Visual display of machine operation*
- IEC 60529:1989, *Degrees of protection provided by enclosures (IP Code)*
- IEC 60529:1989/AMD2:2013, *Amendment 2 - Degrees of protection provided by enclosures (IP Code)*
- ISO 7000:2019, *Graphical symbols for use on equipment — Registered symbols*
- ISO 5010:2019, *Earth-moving machinery — Wheeled machines — Steering requirements*
- ISO 3450:2011, *Earth-moving machinery — Wheeled or high-speed rubber-tracked machines — Performance requirements and test procedures for brake systems*
- ISO 5006:2017, *Earth-moving machinery — Operator's field of view — Test method and performance criteria*
- ISO 12509:2004, *Earth-moving machinery — Lighting, signalling and marking lights, and reflex-reflector devices*
- ISO 9533:2010, *Earth-moving machinery — Machine-mounted audible travel alarms and forward horns — Test methods and performance criteria*

- ISO 9244:2008, *Earth-moving machinery — Machine safety labels — General principles*
- ISO 9244:2008/Amd 1:2016, *Earth-moving machinery — Machine safety labels — General principles — Amendment 1*
- ISO 6395:2008, *Earth-moving machinery — Determination of sound power level — Dynamic test conditions*
- ISO 6396:2008, *Earth-moving machinery — Determination of emission sound pressure level at operator's position — Dynamic test conditions*
- ISO 3457:2003, *Earth-moving machinery — Guards — Definitions and requirements*
- ISO 13857:2019, *Safety of machinery — Safety distances to prevent hazard zones being reached by upper and lower limbs*
- ISO 10570:2004, *Earth-moving machinery — Articulated frame lock — Performance requirements*
- ISO 10532:1995, *Earth-moving machinery — Machine-mounted retrieval device — Performance requirements*
- ISO 10532:1995/Amd 1:2004, *Earth-moving machinery — Machine-mounted retrieval device — Performance requirements — Amendment 1*
- ISO 15818:2017, *Earth-moving machinery — Lifting and tying-down attachment points — Performance requirements*
- ISO 13766-1:2018, *Earth-moving and building construction machinery — Electromagnetic compatibility (EMC) of machines with internal electrical power supply — Part 1: General EMC requirements under typical electromagnetic environmental conditions*
- ISO 13766-2:2018, *Earth-moving and building construction machinery — Electromagnetic compatibility (EMC) of machines with internal electrical power supply — Part 2: Additional EMC requirements for functional safety*
- ISO 14990-1:2016, *Earth-moving machinery — Electrical safety of machines utilizing electric drives and related components and systems — Part 1: General requirements*
- ISO 14990-2:2016, *Earth-moving machinery — Electrical safety of machines utilizing electric drives and related components and systems — Part 2: Particular requirements for externally-powered machines*
- ISO 14990-3:2016, *Earth-moving machinery — Electrical safety of machines utilizing electric drives and related components and systems — Part 3: Particular requirements for self-powered machines*
- ISO 11862:1993, *Earth-moving machinery — Auxiliary starting aid electrical connector*
- ISO 4413:2010, *Hydraulic fluid power — General rules and safety requirements for systems and their components*
- ISO 4414:2010, *Pneumatic fluid power — General rules and safety requirements for systems and their components*
- ISO 16528-1:2007, *Boilers and pressure vessels — Part 1: Performance requirements*
- ISO 16528-2:2007, *Boilers and pressure vessels — Part 2: Procedures for fulfilling the requirements of ISO 16528-1*
- ISO 21507:2010, *Earth-moving machinery — Performance requirements for non-metallic fuel tanks*
- ISO 3795:1989, *Road vehicles, and tractors and machinery for agriculture and forestry — Determination of burning behaviour of interior materials*
- ISO 14120:2015, *Safety of machinery — Guards — General requirements for the design and construction of fixed and movable guards*

ISO/FDIS 6085:2022(E)

ISO 2860:1992, *Earth-moving machinery — Minimum access dimensions*

ISO 10533:1993, *Earth-moving machinery — Lift-arm support devices*

ISO 10533:1993/Amd 1:2005, *Earth-moving machinery — Lift-arm support devices — Amendment 1*

ISO 6750-1:2019, *Earth-moving machinery — Operator's manual — Part 1: Contents and format*

ISO 4871:1996, *Acoustics — Declaration and verification of noise emission values of machinery and equipment*

ISO 18650-1:2021, *Building construction machinery and equipment — Concrete mixers — Part 1: Commercial specifications*

3 Terms and definitions

For the purposes of this document, the terms and definitions given in ISO 12100:2010, ISO 18650-1:2021 and the following apply.

ISO and IEC maintain terminology databases for use in standardization at the following addresses:

- ISO Online browsing platform: available at <https://www.iso.org/obp>
- IEC Electropedia: available at <https://www.electropedia.org/>

3.1 self-loading equipment

integral mounted bucket-supporting structure and linkage permanently fitted to the machine, enabling it to fill its own rotating drum with material

[SOURCE: ISO 20474-6:2017, 3.6, modified — In the definition, "dumper" has been replaced by "machine"; "open body" has been replaced by "rotating drum".]

3.2 operating mass

mass of the machine, with rotating drum and *self-loading equipment* (3.1) empty, and with the operator (75 kg), full fuel tank and all fluid systems (i.e. hydraulic oil, transmission oil, engine oil, engine coolant) at the levels specified by the manufacturer and with empty water tank(s)

4 Safety requirements, protective measures and risk reduction

4.1 General

Machines shall conform to the safety requirements and protective and risk reduction measures stated in this clause. In addition, the machines shall be designed according to the principles of ISO 12100:2010 for relevant but not significant hazards, which are not dealt with by this document.

4.2 Access systems

4.2.1 General requirements

Access systems shall be provided to the operator's station(s) and to routine maintenance points. Access systems shall conform to ISO 2867:2011.

4.2.2 Access to articulated machines

On machines with articulated frames and in the fully articulated steering position, a minimum clearance of 150 mm shall be provided between firm structures and components with relative movement in the path of the access systems to the operator's station, as illustrated in [Figure 1](#).

Dimensions in millimetres

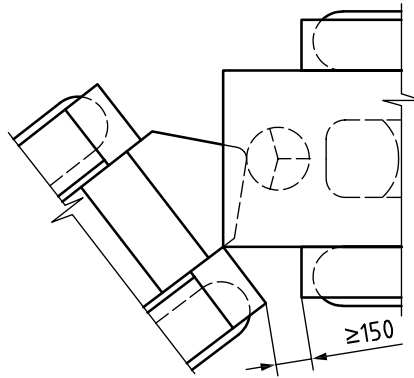

Figure 1 — Minimum clearance for access to operator's station on machines with articulated frame

4.3 Operator's station

4.3.1 General requirements

4.3.1.1 Machinery equipment

Machines with a ready-concrete capacity greater than 2,5 m³ shall have the possibility of being fitted with a cab.

4.3.1.2 Minimum space

The minimum space available to the operator shall be as defined in ISO 3411:2007, with the following exceptions:

- dimension R_1 as defined in ISO 3411:2007, Table 1, may be reduced to a minimum of 920 mm;
- the internal operator's space envelope width from the lower end of upper side walls of enclosure as defined in ISO 3411:2007 may be reduced to a minimum of 650 mm.

The minimum space and location of the controls at the operator's station shall meet the requirements of ISO 6682:1986 and ISO 6682:1986/Amd 1:1989.

4.3.1.3 Moving parts

The machine shall be designed so as to avoid accidental contact from the operating position with moving parts (e.g. wheels, tracks, working equipment, attachments) in accordance with [4.13.2](#).

4.3.1.4 Engine exhaust

The engine exhaust system shall release the exhaust gas away from the operator and the air inlet of the cab.

4.3.1.5 Instruction storage

A space intended for the safekeeping of the operator's manual and other instructions shall be provided near the operator's station.

4.3.1.6 Sharp edges

The operator's working space within the operator's station (e.g. ceiling, inner walls, instrument panels, access to the operator's station) shall not present any sharp exposed edges or acute angles/corners. The radius of corners and the bluntness of edges shall conform to ISO 12508:1994, in order to avoid sharp edges (see also [4.13.5](#)).

4.3.2 Operator's station equipped with a cab

4.3.2.1 Climatic conditions

The cab shall protect the operator against foreseeable adverse climatic conditions. Provisions shall be made to install a ventilation system, an adjustable heating system and a system for defrosting windows. For details, see [4.3.2.5](#) to [4.3.2.7](#).

4.3.2.2 Pipes and hoses

Pipes and hoses that contain fluids at pressures exceeding 5 MPa or temperatures above 60 °C located inside the cab shall be guarded in accordance with ISO 3457:2003, Clause 9. See also [4.16.3](#).

Parts or components placed between pipes or hoses and the operator, which divert a hazardous spray of fluid, may be considered as a sufficient protection device.

4.3.2.3 Primary opening

A primary access opening shall be provided. The dimensions shall be in accordance with ISO 2867:2011.

4.3.2.4 Alternative opening

An alternative opening shall be provided on a side other than that of the primary opening. The dimensions shall be in accordance with ISO 2867:2011. A window panel or another door is acceptable if they are easy to open or remove without the use of keys or tools. Latches may be used if they can be opened from the inside without the use of keys or tools. The breaking of a suitable size of glass pane is considered to represent a suitable alternative opening, provided that the necessary pane hammer, immediately accessible to the operator, is provided and stored in the cab.

When the window panel is used as an emergency exit, it shall bear an appropriate marking. For example, see ISO 7010-E001 or ISO 7010-E002.

4.3.2.5 Heating system

A heating system, if fitted, shall conform to ISO 10263-4:2009. If the cab is not equipped with a pressurization system then ISO 10263-4:2009, 6.1.1 is not applicable.

4.3.2.6 Ventilation system

The ventilation system shall be capable of providing the cab with fresh air at a minimum of 43 m³/h.

4.3.2.7 Defrosting system

A defrosting system shall provide facilities for defrosting the front and rear windows, for example, by means of a heating system or a particular defrosting device.

A test method for windscreen defrosting systems is given in ISO 10263-5.