



Designation: D5397 – 07 (Reapproved 2012)

Standard Test Method for Evaluation of Stress Crack Resistance of Polyolefin Geomembranes Using Notched Constant Tensile Load Test¹

This standard is issued under the fixed designation D5397; the number immediately following the designation indicates the year of original adoption or, in the case of revision, the year of last revision. A number in parentheses indicates the year of last reapproval. A superscript epsilon (ϵ) indicates an editorial change since the last revision or reapproval.

1. Scope

1.1 This test method is used to develop test data from which the susceptibility of polyolefin geomembrane sheet material to stress cracking under a constant tensile load condition and an accelerated environmental condition can be evaluated.

1.2 This test method measures the failure time associated with a given test specimen at a specified tensile load level. Results from a series of such tests utilizing a range of load levels can be used to construct a stress-time plot on a log-log axis.

1.3 The values stated in SI units are to be regarded as the standard. The inch-pound units given in parentheses are provided for information only.

1.4 *This standard does not purport to address all of the safety concerns, if any, associated with its use. It is the responsibility of the user of this standard to establish appropriate safety and health practices and determine the applicability of regulatory limitations prior to use.*

2. Referenced Documents

2.1 *ASTM Standards:*²

[D638 Test Method for Tensile Properties of Plastics](#)

[D883 Terminology Relating to Plastics](#)

[D4354 Practice for Sampling of Geosynthetics and Rolled Erosion Control Products \(RECPs\) for Testing](#)

[D4833 Test Method for Index Puncture Resistance of Geomembranes and Related Products](#)

3. Terminology

3.1 *Definitions:*

3.1.1 *geomembrane, n*—very low permeability synthetic membrane liners or barriers used with any geotechnical engi-

neering related material so as to control fluid migration in a man-made project, structure, or system (see Test Method [D4833](#)).

3.1.2 *stress crack, n*—an external or internal crack in a plastic caused by tensile stresses less than its short-time mechanical strength (see Definitions [D883](#)).

3.1.2.1 *Discussion*—The development of such cracks is frequently accelerated by the environment to which the plastic is exposed. The stresses that cause cracking may be present internally or externally or may be combinations of these stresses.

4. Summary of Test Method

4.1 This test method consists of subjecting a dumbbell shaped notched test specimen from a polyolefin sheet to a constant tensile load in the presence of a surface-active agent and at an elevated temperature. The time to failure of the test specimen is recorded. The results of a series of such tests conducted at different stress levels are presented by plotting stress level against failure time for each stress level on a log-log axis.

5. Significance and Use

5.1 This test method does not purport to interpret the resulting response curve. Such interpretation is left to the parties involved in the commissioning and reporting of the test results.

5.2 This test method is intended as an index test and may be used for grading polyolefin geomembrane sheets in regard to their stress cracking sensitivity.

5.2.1 Conditions that can affect stress cracking include: level of loading, test temperature and environment, microstructure, polymer additive package, processing history, and thermal history.

6. Apparatus

6.1 *Blanking Die*—A die suitable for cutting test specimens to the dimensions and tolerances shown in [Fig. 1](#).

NOTE 1—The length of the specimen can be changed to suit the design of the test apparatus. However, there should be a constant neck section with length at least 13 mm (0.5 in.) long. The width should be 3.20 mm (0.125 in.).

¹ This test method is under the jurisdiction of ASTM Committee [D35](#) on Geosynthetics and is the direct responsibility of Subcommittee [D35.02](#) on Endurance Properties.

Current edition approved July 1, 2012. Published July 2012. Originally approved in 1993. Last previous edition approved in 2007 as D5397–07. DOI: 10.1520/D5397-07R12.

² For referenced ASTM standards, visit the ASTM website, www.astm.org, or contact ASTM Customer Service at service@astm.org. For *Annual Book of ASTM Standards* volume information, refer to the standard's Document Summary page on the ASTM website.

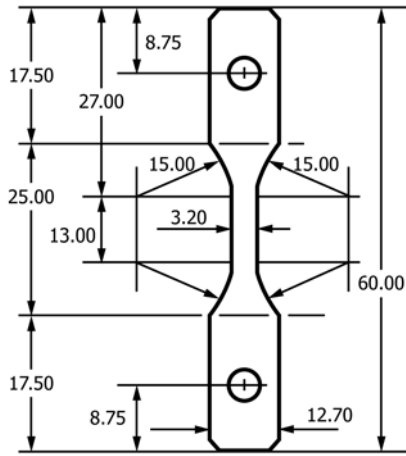

NOTE 1—Dimensioned in millimetres to an accuracy of 0.02 mm.
FIG. 1 Dimensions of Test Method D1822 Type "L" Test Specimens

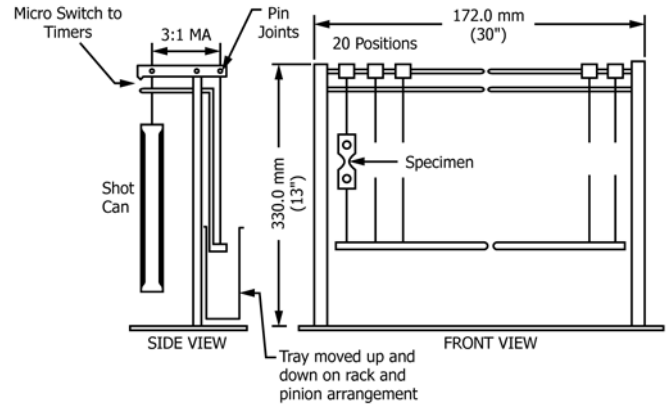

NOTE 1—The number of positions in the test frame is optional.
FIG. 2 Constant Stress Loading Apparatus Consisting of Twenty Specimen Test Positions

6.2 *Notching Device*—A device or machine that can produce a consistent notch depth.³

NOTE 2—An evaluation of the notching technique can be performed by quenching a notched specimen in liquid nitrogen and then fracturing it. The notch depth can readily be measured by examining the fracture surface under a reflected light microscope. Other methods of verifying notch depth include viewing the cut specimen on its side in a microscope with the aid of a eyepiece micrometer or a calibrated reticle.

6.3 *Blade*—A single-edged razor made of carbon steel. The tip profile is that of an arrow rather than that of a chisel point. The sharpness of the point is critical to the cleanliness of the cut which effects the results of the test significantly.

6.4 *Stress Cracking Apparatus*—Equipment suitable for subjecting test specimens to a tensile stress of up to 13.8 MPa (2000 lb/in.²). The specimens shall be maintained at a constant temperature of 50 ± 1°C (122 ± 2°F) while being totally immersed in a surface-active agent. The solution should be constantly agitated to provide a uniform concentration throughout the bath.

NOTE 3—The apparatus⁴ shown in Fig. 2 is one type that has been used and is capable of testing up to 20 specimens at a time. This equipment uses a lever system with a mechanical advantage (MA) of three to impose the desired loading on each specimen. The surface-active agent in which the specimens are immersed is contained in an open stainless steel tank. A submersion heater and controller are used to maintain the test temperature. A pump keeps the liquid in a constant state of agitation. A timing clock for each test specimen is also provided to record automatically the failure time of the test specimens to the nearest 0.1 h.

NOTE 4—If "on/off" switches are used to control the timing clock, the switch must be sensitive enough to be turned off under 200 g of the force.

7. Reagent

7.1 The reagent should consist of 10 % surface-active agent with 90 % water. The surface-active agent is Igepal CO-630⁵

³ Notching equipment is available through REMCO Industrial Machine Co., Manville, NJ 08850.

⁴ This equipment is available through Custom Scientific Instruments Co., Cedar Knolls, NJ 07927, and BT Technology Inc., 613 W. Clinton St., Rushville, IL 62681.

⁵ Igepal CO-630 may be obtained from Rhone-Poulenc, CN 7500, Prospect Plains Road, Cranbury, NJ 08512-7500.

that is nonylphenoxy poly(ethyleneoxy)ethanol. The reagent should be stored in a closed container. The reagent in the bath should be replaced every two weeks to maintain a constant concentration.

NOTE 5—In case of dispute, the water should be distilled or deionized at the discretion of the parties involved.

NOTE 6—Other incubation solutions may also be used in the test, provided that the parties involved mutually agree to the changes and state the specific details in the final report.

8. Sampling

8.1 *Lot Sample*—Divide the product into lots and take the lot sample as directed in Practice D4354.

8.2 *Laboratory Sample*—As a laboratory sample for acceptance testing, take a full-width swatch approximately 1 m (40 in.) long in the machine direction from each roll in the lot sample. The sample may be taken from the end portion of a roll provided there is no evidence it is distorted or different from other portions of the roll.

8.3 *Test Specimens*—At least thirty test specimens are cut from each swatch in the laboratory sample. For each set of tests, all specimens must be taken from one direction.

NOTE 7—Quite often the test is required to challenge the weakest direction of the sheet material. If this is the cross machine direction, the test specimens should be cut in this direction. Hence the notch is placed in the machine direction so that the specimens are stressed in the desired cross machine direction.

NOTE 8—It has been found that inserting a grommet or eyelet in the two holes at the end tabs of the test specimen helps to reduce the number of "grip failures" or failures occurring outside of the neck section of the specimen.

9. Procedure

9.1 Measure the thickness of each individual test specimen at its minimum cross section to the nearest 0.013 mm (0.001 in.). The variation in thickness should not be greater than ± 0.026 mm (± 0.002 in.) of the nominal thickness of the geomembrane.

9.2 Cut into each specimen a control imperfection (notch) on one surface as shown in Fig. 3. The depth of the notch