



Designation: E675 – 02 (Reapproved 2012)

Standard Specification for Interchangeable Taper-Ground Stopcocks And Stoppers¹

This standard is issued under the fixed designation E675; the number immediately following the designation indicates the year of original adoption or, in the case of revision, the year of last revision. A number in parentheses indicates the year of last reapproval. A superscript epsilon (ϵ) indicates an editorial change since the last revision or reapproval.

1. Scope

1.1 The specification provides standard dimensional requirements for obtaining, within practical limits, interchangeability in stopcocks and stoppers for ordinary laboratory and industrial applications. It covers dimensional interchangeability of the ground surfaces only and does not involve design characteristics of the item except where specified.

NOTE 1—The dimensions pertaining to stopcocks and stoppers were taken from the Commercial Standard CS 21 of the U.S. Department of Commerce.

NOTE 2—Although glass is the most commonly used material for stopcocks and stoppers, other materials may be used as specified. Stopcocks and stoppers constructed from glass should conform to Specifications E438 and E671.

2. Referenced Documents

2.1 *ASTM Standards*:²

E438 Specification for Glasses in Laboratory Apparatus

E671 Specification for Maximum Permissible Thermal Residual Stress in Annealed Glass Laboratory Apparatus

E920 Specification for Commercially Packaged Laboratory Apparatus

E921 Specification for Export Packaged Laboratory Apparatus

E1133 Practice for Performance Testing of Packaged Laboratory Apparatus for United States Government Procurements

E1157 Specification for Sampling and Testing of Reusable Laboratory Glassware

2.2 *U.S. Department of Commerce Standard*:

CS 21 Interchangeable Taper-Ground Joints, Stopcocks, Stoppers, and Spherical-Ground Joints³

¹ This specification is under the jurisdiction of ASTM Committee E41 on Laboratory Apparatus and is the direct responsibility of Subcommittee E41.01 on Apparatus.

Current edition approved Nov. 1, 2012. Published November 2012. Originally approved in 1979. Last previous edition approved in 2007 as E675 – 02(2007). DOI: 10.1520/E0675-02R12.

² For referenced ASTM standards, visit the ASTM website, www.astm.org, or contact ASTM Customer Service at service@astm.org. For *Annual Book of ASTM Standards* volume information, refer to the standard's Document Summary page on the ASTM website.

³ *Discontinued 1979*—U.S. Department of Commerce, Washington, DC 20234.

3. Requirements for Single Straight-Bore Taper-Ground Stopcocks

3.1 The designations and dimensions for single straight-bore stopcocks shall be as shown in Fig. 1 and Table 1.

3.2 *Taper*—All straight-bore stopcocks shall have a taper of 1 ± 0.006 mm of diameter per 10 mm of length (1 to 10).

3.3 *Master Gages*—Dimensions and tolerances for master gages shall be as shown in Fig. 2 and Fig. 3, and Table 2 and Table 3. Overall diameter of ring gage shall be approximately twice the diameter of the bore at the reference line in the window, but not less than 25 mm.

3.3.1 *Plug Gage*—Plug shall have two short axial lines $180 \pm 0.5^\circ$ apart intersecting the reference line for checking location of bore hole. In addition to the two axial lines 180° apart intersecting the reference line on the 4 and 6-mm plugs, two additional axial lines shall be provided on each of these plugs for checking the location of the bore hole of T-bore and 120-deg bore stopcocks. These two additional axial lines shall be placed 90 and $120^\circ (\pm 0.5^\circ)$ from one of the first two axial lines.

3.3.2 *Ring Gage*—The central milled recess, or window, shall be placed approximately midway between the ends of the ring gage. Width of recess measured parallel with the axis shall be approximately one fourth of the length of the ring, and the width of the opening at the inner surface of ring, measured perpendicular to the axis, shall not exceed one fourth of the length of the ring. Reference line in recess shall be placed approximately midway between ends of ring gage.

3.3.3 *Fit of Product in Working Gages*—The product (both inner and outer members) shall fit the corresponding working gages so that the centerline through the bore corresponds with the reference line on the gage within ± 0.3 mm for 1, $1\frac{1}{2}$, and 2-mm bores; ± 0.5 mm for 3 and 4-mm bores; and ± 1.0 mm for 5-mm and larger bores.

4. Requirements for Single Oblique-Bore Stopcocks

4.1 Design, dimensions, and tolerances for 1, $1\frac{1}{2}$, 2, 3, and 4-mm oblique-bore stopcocks shall be as shown in Fig. 4 and Table 4.

4.2 *Taper*—All single oblique-bore stopcocks shall have a taper of 1 ± 0.006 mm of diameter per 10 mm of length (1 to 10).

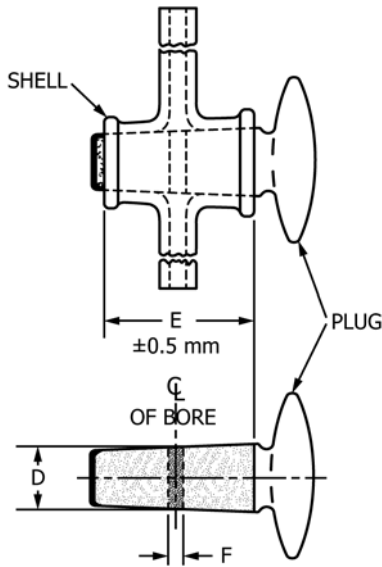

FIG. 1 Stopcock

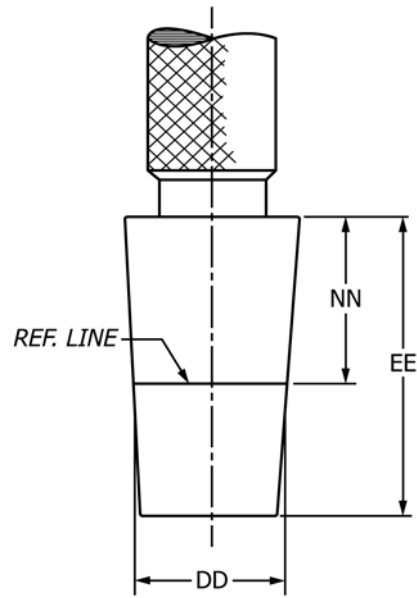

FIG. 2 Master Plug Gage for Single Straight-Bore Stopcocks

TABLE 1 Single Straight-Bore Stopcocks

Stopcock Designation	Diameter of Plug at Center-Line of Bore, mm <i>D</i>	Length of Shell, ±0.5 mm <i>E</i>	Diameter of Bore Hole in Plug, mm <i>F</i>
1-M ^A	7	20	1
1	12	30	1
1½	12	30	1½
2	12	30	2
3	17	40	3
4	17	40	4
5	20	44	5
6	20	44	6
8	25	52	8
10	35	56	10

^A Micro size.

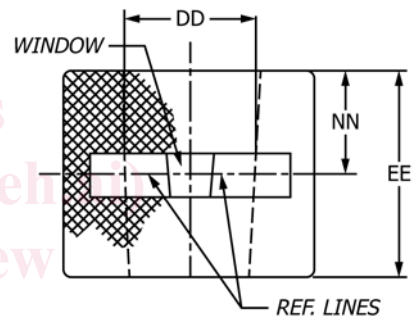

FIG. 3 Master Ring Gage for Single Straight-Bore Stopcocks

4.3 *Master Gages*—The dimensions and tolerances for master gages shall be as shown in Fig. 5 and Fig. 6 and Table 5 and Table 6. The overall diameter of the ring gage shall be approximately twice the diameter of the bore at its midpoint, but not less than 25 mm.

4.3.1 *Plug Gage*—The upper circumferential reference line shall be the gaging point. Each reference line shall have a short axial line intersecting it, the two axial lines being on opposite sides of the plug and in the same plane running through the axis ($180 \pm 0.5^\circ$ apart) for checking location of bore holes.

4.3.2 *Ring Gage*—The width of the milled recesses, or windows, measured parallel with the axis shall be approximately one fourth of the length of the ring, and the width of the opening at the inner surface of ring, measured perpendicular to the axis, shall not exceed one fourth of the length of the ring. The recesses shall be so placed that the reference lines fall approximately midway in the recess.

4.3.3 *Fit of Product in Working Gages*—The product (both inner and outer members) shall fit the corresponding working gages so that the centerlines through the openings correspond with the reference lines on the gages within ± 0.3 mm for 1, 1½, and 2-mm bores, and ± 0.5 mm for 3 and 4-mm bores.

5. Requirements for Double Oblique-Bore (Three-Way) Stopcocks

5.1 Design, dimensions, and tolerances for 1, 1½, 2, 3, and 4-mm, three-way bore stopcocks shall be as shown in Fig. 7 and Table 7.

5.2 *Taper*—All double oblique-bore stopcocks shall have a taper of 1 ± 0.006 mm of diameter per 10 mm of length (1 to 10).

5.3 *Master Gages*—Dimensions and tolerances for master gages shall be as shown in Fig. 8 and Fig. 9 and Table 8 and Table 9. The overall diameter of the ring gage shall be

TABLE 2 Master Plug Gages for Single Straight-Bore Stopcocks

Stopcock Designation	Length of Tapered Portion +2.0 mm, -0 mm <i>EE</i>	Diameter at Gaging Point ±0.003 mm <i>DD</i>	Distance from Large End of Tapered Portion to Gaging Point, mm <i>NN</i>
1-M ^A	32	7	20
1	42	12	25
1½	42	12	25
2	42	12	25
3	52	17	30
4	52	17	30
5	56	20	32
6	56	20	32
8	64	25	36
10	68	35	38

^A Micro size.

TABLE 3 Master Ring Gages for Single Straight-Bore Stopcocks

Stopcock Designation	Length of Ring, +0.2 mm, -0 mm <i>EE</i>	Inside Diameter at Gaging Point, ±0.003 mm <i>DD</i>	Distance from Top to Gaging Point, mm <i>NN</i>
1-M ^A	20	7	10
1	30	12	15
1½	30	12	15
2	30	12	15
3	40	17	20
4	40	17	20
5	44	20	22
6	44	20	22
8	52	25	26
10	56	35	28

^A Micro size.

approximately twice the diameter of the bore at the reference line in the central window.

5.3.1 *Plug Gage*—The central circumferential reference line shall be the gaging point. A short axial reference line shall intersect each of the circumferential reference lines. The axial line intersecting the central circumferential reference line shall be on the opposite side of the plug from the other two axial lines. All three axial lines shall be in the same plane running through the axis ($180 \pm 0.5^\circ$) to check the location of the bore holes.

5.3.2 *Ring Gage*—The width of the milled recesses, or windows, measured parallel with the axis shall be approximately one fourth of the length of the ring, and the width of the opening at the inner surface of ring, measured perpendicular to the axis, shall not exceed one fourth of the length of the ring. The recesses shall be so placed that the reference lines fall approximately midway in the recesses.

5.3.3 *Fit of Product in Working Gages*—The product (both inner and outer members) shall fit the corresponding working gages so that the centerlines through the openings correspond with the reference lines on the gage within ± 0.3 mm for 1, 1½, and 2-mm bores, and ± 0.5 mm for 3 and 4-mm bores.

6. Requirements for T-Bore and 120-deg Bore Stopcocks

6.1 These stopcocks are designated by the nominal bore size. With the exception of the bore sizes, the dimensions and tolerances for 1, 1½, and 2-mm T-bore and 120-deg bore

stopcocks shall be the same as for the 4-mm single straight-bore stopcocks. Dimensions and tolerances for 3 and 4-mm T-bore and 120-deg bore stopcocks shall be the same as for the 6-mm single-bore stopcocks. (See [Table 1](#).)

6.2 *Taper*—All T-bore and 120-deg bore stopcocks shall have a taper of 1 ± 0.006 mm of diameter per 10 mm of length (1 to 10).

6.3 Master Gages:

6.3.1 *Plug Gage*—The 4-mm single straight-bore gage shall be used for 1, 1½, and 2-mm T-bore and 120-deg bore, and 6-mm single straight-bore gage for 3 and 4-mm T-bore and 120-deg bore stopcocks.

6.3.2 *Ring Gage*—To check diameter at the centerline of the bore, the 4-mm single straight-bore ring gage shall be used for the 1, 1½, and 2-mm sizes; and the 6-mm single straight-bore ring gage for the 3 and 4-mm sizes of T-bore and 120-deg bore stopcocks.

6.3.3 *Ring Gage for Locating Position of Bores for T-Bore and 120-deg Bore*—The length of the ring gage shall be 25 ± 1.0 mm for all sizes. The outside diameter of the rings shall be approximately twice the diameter at the centerline of the bore. The inside diameter at the large end of the tapered portion shall be equal to the diameter at the centerline of the bore of the plug (product) ± 0.1 mm. Four reference lines approximately 0.1 mm wide shall be provided on the upper face of the gage at right angles to the vertical axis. Two lines shall be $180 \pm 0.5^\circ$ apart, and the other two lines shall be $90 \pm 0.5^\circ$ and $120 \pm 0.5^\circ$ from one of the first two lines.

7. Requirements for Taper-Ground Flask Stoppers

7.1 The designations and dimensions for taper-ground flask stoppers shall be as shown in [Fig. 10](#) and [Table 10](#).

7.2 *Taper*—All taper-ground flask stoppers shall have a taper of 1 ± 0.006 mm of diameter per 10 mm of length (1 to 10).

7.3 *Master Gages*—Dimensions and tolerances for master gages shall be as shown in [Fig. 11](#) and [Fig. 12](#) and [Table 11](#) and [Table 12](#). The overall diameter of the ring gage shall be approximately twice the diameter of the small end of the bore, but not less than 25 mm.

7.3.1 *Fit of Product in Working Gages*—The large end of stopper shall come flush with large end of ring gage within ± 0.5 mm along the axis for stopper Nos. 8 to 19, inclusive; and within ± 1.0 mm along the axis for stopper Nos. 22 and 38, inclusive.

7.3.2 The plug gage shall enter the flask so that gaging point on plug shall be at least 0.5 mm and not over 1.5 mm above the extreme top surface of the flask for stopper Nos. 8 to 19, inclusive; and at least 1.0 mm and not over 3.0 mm for stopper Nos. 22 to 38, inclusive.

8. Requirements for Taper-Ground Bottle Stoppers

8.1 The designations and dimensions of taper-ground reagent bottle stoppers shall be as shown in [Fig. 13](#) and [Table 13](#).

8.2 *Taper*—All taper-ground reagent bottle stoppers shall have a taper of 1 ± 0.006 mm of diameter per 10 mm of length.

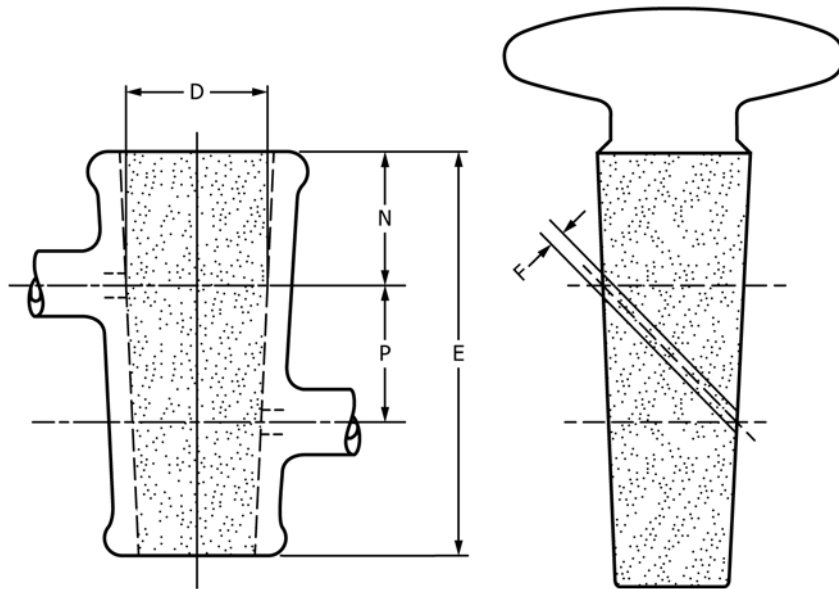

FIG. 4 Single Oblique-Bore Stopcock

TABLE 4 Single Oblique-Bore Stopcock

Stopcock Designation	Diameter of Plug at Gaging Point, mm <i>D</i>	Length of Shell, ±0.5 mm <i>E</i>	Diameter of Bore in Plug, mm <i>F</i>	Distance from Large End of Shell to Gaging Point, ±0.5 mm <i>N</i>	Distance between Bore Holes, <i>P</i> ^A
1	12.60	40	1	14.0	12
1½	12.60	40	1½	14.0	12
2	12.60	40	2	14.0	12
3	17.35	50	3	16.5	17
4	17.35	50	4	16.5	17

^A See 3.3.3.

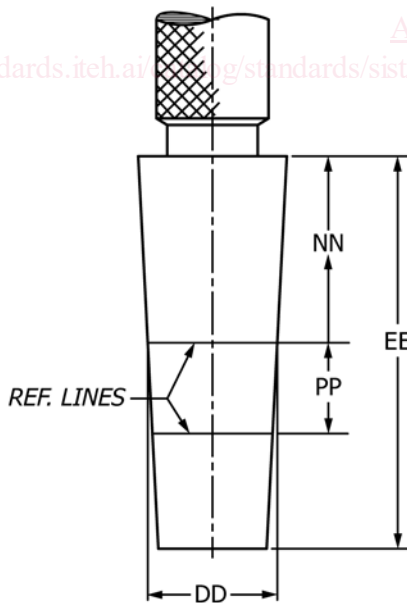

FIG. 5 Master Plug Gage for Single Oblique-Bore Stopcocks

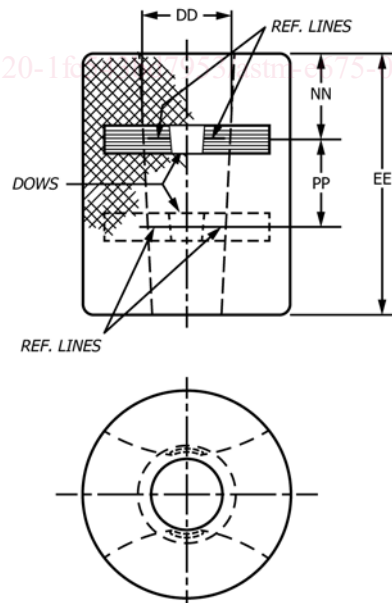

FIG. 6 Master Ring Gage for Single Oblique-Bore Stopcocks

8.3 *Master Gages*—Dimensions and tolerances for master gages shall be as shown in Fig. 14 and Fig. 15 and Table 14 and Table 15. The overall diameter of the ring gage shall be

approximately twice the diameter of the small end of the bore, but not less than 25 mm.

TABLE 5 Master Plug Gages for Single Oblique-Bore Stopcocks

Stopcock Designation	Length of Tapered Portion, +2.0 mm, -0 mm <i>EE</i>	Diameter at Gaging Point, ± 0.003 mm <i>DD</i>	Distance from Large End of Tapered Portion to Gaging Point +1.5 mm, -0 mm <i>NN</i>	Distance from Gaging Point to Lower Reference Line ± 0.03 mm <i>PP</i>
1	52	12.60	24.5	12
1½	52	12.60	24.5	12
2	52	12.60	24.5	12
3	62	17.35	27.0	17
4	62	17.35	27.0	17

TABLE 6 Master Ring Gages for Single Oblique-Bore Stopcocks

Stopcock Designation	Length of Ring, +0.2 mm, -0 mm <i>EE</i>	Inside Diameter at Gaging Point, ± 0.003 mm <i>DD</i>	Distance from Top to Gaging Point (Approximate) <i>NN</i>	Distance from Gaging Point to Lower Reference Point, ± 0.03 mm <i>PP</i>
1	40	12.60	14.0	12
1½	40	12.60	14.0	12
2	40	12.60	14.0	12
3	50	17.35	16.5	17
4	50	17.35	16.5	17

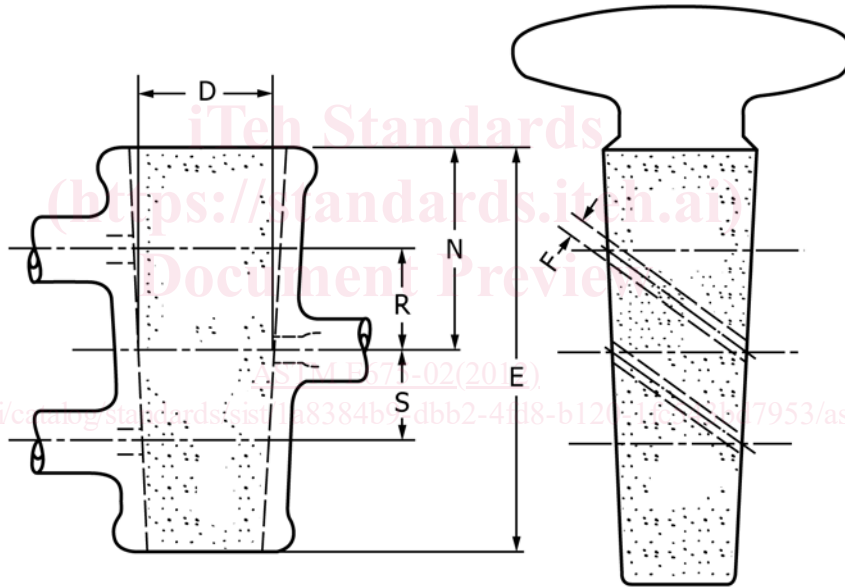

FIG. 7 Double Oblique-Bore Stopcock

8.3.1 *Fit of Product in Working Gages*— The large end of the stopper shall come flush with large end of ring gage within ± 0.5 mm along the axis for stopper Nos. 14 and 19, and within ± 1.0 mm along the axis for stopper Nos. 24 to 45, inclusive.

8.3.2 The plug gage shall enter bottle so that gaging point on plug shall be at least 0.5 mm and not over 1.5 mm above the extreme top surface of the bottle for stopper Nos. 14 and 19; and at least 1.0 mm and not over 3.0 mm for stopper Nos. 24 to 45, inclusive.

9. Sampling and Testing

9.1 For sampling and testing refer to Specification E1157.

10. Product Marking

10.1 Interchangeable taper-ground stopcocks, and stoppers conforming to this specification may be marked on both members with (), indicating standard taper, the size designation, and the trade-mark of the manufacturer or distributor. This symbol is the manufacturer's assurance to purchasers that the item identified by the symbol is a standard interchangeable size and type, and is manufactured within the tolerances permitted by this specification. It shall not be used on stopcocks, or stoppers, nor in advertising descriptions of stopcocks, or stoppers of any size or type other than those described in this specification.

TABLE 7 Double Oblique-Bore Stopcock

Stopcock Designation	Diameter of Plug at Gaging Point, mm D	Length of Shell, ± 0.5 mm E	Diameter of Bore in Plug, mm F	Distance from Large End of Shell to Gaging point, ± 0.5 mm N	Distance from Gaging Point to Centerline of Bore Near Large End, mm R^A	Distance from Gaging Point to Centerline of Bore Near Small End S^A
1	14.5	50	1	25	12.5	11.5
1½	14.5	50	1½	25	12.5	11.5
2	14.5	50	2	25	12.5	11.5
3	16.2	56	3	28	14.0	12.9
4	16.2	56	4	28	14.0	12.9

^A See 3.3.3.

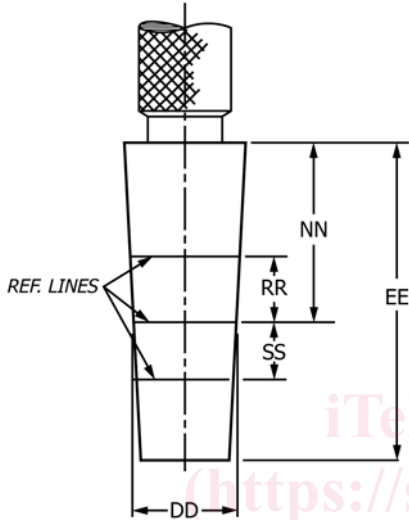

FIG. 8 Master Plug Gage for Double Oblique-Bore Stopcock (Three-Way)

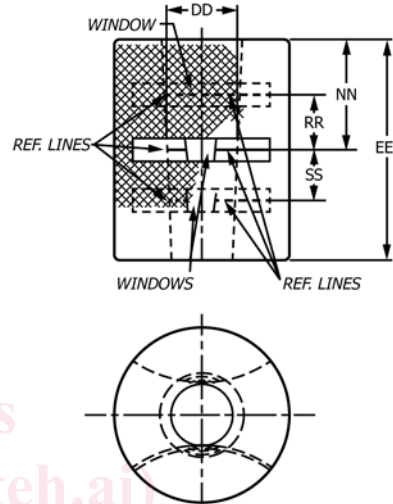

FIG. 9 Master Ring Gage for Double Oblique-Bore Stopcock (Three-Way)

11. Packaging

11.1 For packaging select from Specifications E920, E921,

12. Keywords

or Practices E1133. <https://standards.iteh.ai/catalog/standards/sist/1a8384b9-dbb2-4188-b65841-130523/astm-e675-022012> 12.1 ground; stopcocks; stoppers