



SLOVENSKI STANDARD
SIST ISO 3083:1998

01-februar-1998

Železne rude -- Priprava vzorcev -- Ručna metoda

Iron ores -- Preparation of samples -- Manual method

Minerais de fer -- Préparation des échantillons -- Méthode manuelle

Ta slovenski standard je istoveten z: ISO 3083:1986

[SIST ISO 3083:1998](https://standards.iteh.ai/catalog/standards/sist/474daa41-f6fe-46ce-8106-0024c8fab8c/sist-iso-3083-1998)

<https://standards.iteh.ai/catalog/standards/sist/474daa41-f6fe-46ce-8106-0024c8fab8c/sist-iso-3083-1998>

ICS:

73.060.10 Železove rude Iron ores

SIST ISO 3083:1998

en

iTeh STANDARD PREVIEW
(standards.iteh.ai)

SIST ISO 3083:1998

<https://standards.iteh.ai/catalog/standards/sist/474daa41-f6fe-46ee-8106-0024c8fab8c/sist-iso-3083-1998>

International Standard



3083

INTERNATIONAL ORGANIZATION FOR STANDARDIZATION • МЕЖДУНАРОДНАЯ ОРГАНИЗАЦИЯ ПО СТАНДАРТИЗАЦИИ • ORGANISATION INTERNATIONALE DE NORMALISATION

Iron ores — Preparation of samples — Manual method

Minerais de fer — Préparation des échantillons — Méthode manuelle

Second edition — 1986-10-15

iTeh STANDARD PREVIEW
(standards.iteh.ai)

SIST ISO 3083:1998

<https://standards.iteh.ai/catalog/standards/sist/474daa41-f6fe-46ee-8106-0024c8fafb8c/sist-iso-3083-1998>

UDC 553.31 : 620.11

Ref. No. ISO 3083-1986 (E)

Descriptors : minerals and ores, iron ores, samples, specimen preparation, apparatus.

Price based on 16 pages

Foreword

ISO (the International Organization for Standardization) is a worldwide federation of national standards bodies (ISO member bodies). The work of preparing International Standards is normally carried out through ISO technical committees. Each member body interested in a subject for which a technical committee has been established has the right to be represented on that committee. International organizations, governmental and non-governmental, in liaison with ISO, also take part in the work.

Draft International Standards adopted by the technical committees are circulated to the member bodies for approval before their acceptance as International Standards by the ISO Council. They are approved in accordance with ISO procedures requiring at least 75 % approval by the member bodies voting.

International Standard ISO 3083 was prepared by Technical Committee ISO/TC 102, *Iron ores*.

This second edition cancels and replaces the first edition (ISO 3083-1973), of which it constitutes a technical revision.

Users should note that all International Standards undergo revision from time to time and that any reference made herein to any other International Standard implies its latest edition, unless otherwise stated.

Contents

| | Page |
|--|------|
| 1 Scope | 1 |
| 2 Field of application | 1 |
| 3 References | 1 |
| 4 Definitions | 1 |
| 5 General procedures for sample preparation | 2 |
| 6 Fundamentals of sample preparation | 2 |
| 6.1 Precision of sample preparation and overall precision | 2 |
| 6.2 Composition of samples | 3 |
| 6.3 Division rules | 3 |
| 6.4 Method and type of division | 3 |
| 6.5 Split use and multiple use of sample | 3 |
| 6.6 Crushing and grinding | 3 |
| 6.7 Mixing | 4 |
| 6.8 Pre-drying | 4 |
| 6.9 Requirements for sample preparation | 4 |
| 7 Apparatus | 4 |
| 8 Combining increments for sample preparation | 5 |
| 8.1 Combining increments taken by mass-basis sampling | 5 |
| 8.2 Combining increments taken by time-basis sampling | 5 |
| 9 Manual method of division | 5 |
| 9.1 Manual increment division method | 6 |
| 9.2 Manual riffle division method | 7 |
| 9.3 Coning and quartering method | 9 |
| 10 Preparation of test samples | 9 |
| 10.1 Preparation of test sample for size determination | 9 |
| 10.2 Preparation of test sample for moisture determination | 9 |
| 10.3 Preparation of test sample for chemical analysis | 10 |
| 10.4 Example of sample preparation process | 12 |
| 11 Packing and marking of sample | 12 |
| Annexes | |
| A Type of riffle divider | 14 |
| B Procedure for determining the minimum mass of divided size sample by manual riffle division method | 16 |

iTeh STANDARD PREVIEW
(standards.iteh.ai)

ISO 3083-1986
<https://standards.iteh.ai/catalog/standards/sist/474daa41-f6fe-46ce-8106-0024c8fa1b8c/sist-iso-3083-1986>

iTeh STANDARD PREVIEW
(standards.iteh.ai)

SIST ISO 3083:1998

<https://standards.iteh.ai/catalog/standards/sist/474daa41-f6fe-46ce-8106-0024c8fab8c/sist-iso-3083-1998>

Iron ores — Preparation of samples — Manual method

1 Scope

This International Standard specifies

- a) the underlying theory,
- b) the basic principles, and
- c) the basic requirements for the devices and their operation

for the manual method of preparation of samples taken from a consignment of iron ore in accordance with ISO 3081 or ISO 3082, for the purpose of determining the quality characteristics of the consignment.

NOTE — The theory and basic principles given herein are similar to those given in ISO 3081 and ISO 3082.

2 Field of application

The methods specified are applicable to all iron ores, whether natural or processed (for example, concentrates and agglomerates such as pellets, sinters or briquettes).

Samples are prepared for the determination of size distribution, moisture content, and chemical composition.

3 References

ISO 3081, *Iron ores — Increment sampling — Manual method.*

ISO 3082, *Iron ores — Increment sampling and sample preparation — Mechanical method.*¹⁾

ISO 3085, *Iron ores — Experimental methods for checking the precision of sampling.*

ISO 3086, *Iron ores — Experimental methods for checking the bias of sampling.*

ISO 3087, *Iron ores — Determination of moisture content of a consignment.*

4 Definitions

For the purpose of this International Standard, the following definitions apply.

4.1 lot: A definite quantity of an ore, processed or produced under conditions which are presumed uniform.

4.2 consignment: A quantity of an ore delivered at one time. The consignment may consist of one or more lots or parts of lots.

4.3 increment:

(1) A quantity of an ore taken by a sampling device at one time from a consignment.

(2) A quantity taken by the increment division method.

4.4 subsample:

(1) A quantity of an ore consisting of two or more increments taken from a consignment.

(2) An aggregation of two or more increments each of which individually has been optionally crushed and/or optionally divided as necessary.

4.5 gross sample:

(1) The quantity of an ore consisting of all the increments taken from a consignment.

(2) An aggregation of all the increments or all the subsamples each of which individually has been optionally crushed and/or optionally divided as necessary.

4.6 divided sample: A sample obtained by a method of division.

4.7 test sample: Any sample, for the determination of size distribution, moisture content, chemical composition, which is prepared from each increment, each subsample, or from the gross sample in accordance with the specified method for that type of sample.

A representative part of a test sample which is actually subjected to the test is designated the **test portion**. If the entire quantity of a test sample is subjected to the test, the test sample may also be called "test portion".

1) At present at the stage of draft.

4.8 size sample: The sample taken for the determination of size distribution of the consignment.

4.9 moisture sample: The sample taken for the determination of moisture content of the consignment.

4.10 sample for chemical analysis: The sample taken for the determination of chemical composition of the consignment.

4.11 maximum particle size: Particle size expressed in terms of the size of openings of the sieve on which approximately 5 % (*m/m*) of iron ore is retained.

NOTE — The maximum particle size of the consignment may be ascertained either by past experience or by experiment. However, if no information is available, visual estimation is acceptable.

4.12 whole-through sieve size: Particle size expressed by the size of the smallest sieve aperture size through which all of a sample passes.

4.13 sample preparation: The process of making the sample ready for the determination of quality characteristics. It covers sample division, crushing, mixing and sometimes pre-drying and may be performed in several stages.

4.14 sample division: The process in sample preparation whereby the mass of a sample is reduced by partition or extraction without crushing.

4.15 constant-mass division: A type of division for obtaining divided samples having almost uniform mass regardless of the variation in mass of samples to be divided.

NOTE — Almost uniform mass means that the variation in mass shall be less than 20 % in terms of the coefficient of variation (CV).

4.16 fixed-rate division: A type of division for obtaining divided samples having such masses as to be proportional to the varied masses of samples to be divided.

4.17 split use of sample: The sample is split into two or more parts, which are used individually for the determination of their two or more quality characteristics.

4.18 multiple use of sample: The sample in its entirety is used for the determination of one quality characteristic, then the same sample in its entirety or part is used for the determination of other quality characteristics.

4.19 mass-basis sampling: The taking of increments in uniform mass intervals throughout the mass sampled.

4.20 time-basis sampling: The taking of increments in uniform time intervals throughout the mass sampled.

5 General procedures for sample preparation

The increments taken in accordance with ISO 3081 or ISO 3082 for the required determinations shall be prepared into test samples according to the following general procedures:

a) determine whether the test sample is to be prepared from each increment, from each subsample or from the gross sample according to the requirements for the determination of quality characteristics;

b) determine whether the sample is for split use or for multiple use;

c) select the method and type of sample division at each stage;

d) establish the flow of sample preparation including the processes of division, crushing, mixing and pre-drying (if necessary);

e) prepare the test sample according to the procedures mentioned in a) to d).

6 Fundamentals of sample preparation

6.1 Precision of sample preparation and overall precision

The precision of sample preparation, β_D , shall be within $\pm 0,3$ % in total iron or moisture content with a 95 % probability. However, if sample preparation is carried out first on individual increments or subsamples at an appropriate stage of the sample preparation and then those divided increments or subsamples are combined into the gross sample, the precision of sample preparation will be further improved (see 6.1.2 and 6.1.3).

The precision of sample preparation and measurement, β_{DM} , for size determination shall be within the values specified for the type of ore (see table 8).

Variations from the tables in this International Standard may be made, provided it can be demonstrated that the specified precision of sample preparation can be met. The precision should be determined in accordance with ISO 3085.

The overall precision in terms of standard deviation, σ_{SDM} , for the cases where division and measurement are carried out on the gross sample, on each of the subsamples or on each of the increments may be expressed as follows.

6.1.1 When the gross sample is prepared for a consignment and n_7 determinations (chemical analyses) are carried out on the gross sample, the overall precision will be

$$\sigma_{SDM}^2 = \sigma_S^2 + \sigma_D^2 + \frac{\sigma_M^2}{n_7}$$

where

σ_S is the precision of sampling in terms of standard deviation;

σ_D is the precision of sample preparation in terms of standard deviation comprising the processes from the gross sample to the test sample;

σ_M is the precision of measurement in terms of standard deviation.

6.1.2 When n_8 subsamples, each subsample consisting of an equal number of increments, are prepared and n_7 determinations are carried out on each subsample, the overall precision will be

$$\sigma_{\text{SDM}}^2 = \sigma_{\text{S}}^2 + \frac{\sigma_{\text{D}}^2 + (\sigma_{\text{M}}^2/n_7)}{n_8}$$

where σ_{D} is the precision of sample preparation in terms of standard deviation comprising the processes from the subsample to the test sample.

Further, when n_8 subsamples are combined into the gross sample at an appropriate stage after individual sample preparation, and n_7 determinations are carried out on the gross sample, the overall precision will be

$$\sigma_{\text{SDM}}^2 = \sigma_{\text{S}}^2 + \frac{\sigma_{\text{D}_1}^2}{n_8} + \sigma_{\text{D}_2}^2 + \frac{\sigma_{\text{M}}^2}{n_7}$$

where

σ_{D_1} is the precision of sample preparation in terms of standard deviation comprising the processes from the subsample to the divided subsample at an appropriate stage;

σ_{D_2} is the precision of sample preparation in terms of standard deviation comprising the processes from the gross sample at an appropriate stage to the test sample.

6.1.3 When n_7 determinations are carried out on each increment, the overall precision will be

$$\sigma_{\text{SDM}}^2 = \sigma_{\text{S}}^2 + \frac{\sigma_{\text{D}}^2 + (\sigma_{\text{M}}^2/n_7)}{n_1}$$

where

σ_{D} is the precision of sample preparation in terms of standard deviation covering the processes from the increment to the test sample;

n_1 is the number of increments.

Further, when all the increments are combined into the gross sample at an appropriate stage after individual sample preparation, and n_7 determinations are carried out on the gross sample, the overall precision will be

$$\sigma_{\text{SDM}}^2 = \sigma_{\text{S}}^2 + \frac{\sigma_{\text{D}}^2}{n_1} + \frac{\sigma_{\text{M}}^2}{n_7}$$

where σ_{D} is the precision of sample preparation in terms of standard deviation covering the processes from the increment to the divided increment at an appropriate stage.

6.2 Composition of samples

When samples are to be composed of the increments, the following shall be taken into consideration:

- quality characteristics to be determined;
- overall precision required;
- coefficient of variation (CV) in mass of increments taken by mass-basis sampling.

6.3 Division rules

In order to obtain the specified precision of sample preparation the following aspects of division shall be considered:

- minimum mass of the sample after division, specified for each quality characteristic to be determined;
- method and type of division to be adopted;
- whole-through sieve size of the sample to be divided.

6.4 Method and type of division

One or more of the following methods of sample division shall be conducted individually or jointly:

- manual increment division method (see 9.1);
- manual riffle division method (see 9.2);
- coning and quartering method (see 9.3);
- mechanical division method (see ISO 3082).

This International Standard specifies three methods of manual division a), b) and c), which shall be applied to increments or subsamples on the basis of taking increments and division type as shown in table 1.

Combining of increments taken on time-basis sampling and mass-basis sampling shall incorporate the procedures specified in clause 8.

6.5 Split use and multiple use of sample

When a sample taken from the consignment meets the respective requirements for the determination of quality characteristics, the sample may be either in split use or in multiple use for obtaining the test samples for moisture determination, size determination and chemical analysis.

6.6 Crushing and grinding

The crushing and grinding shall be conducted with such a crusher and a grinder as are suitable for the size and hardness of the ore particles.

The crusher and grinder shall be purged with material from the same source.

Table 1 — Application of manual division method¹⁾

| Division of | Conditions of increment | | | | Manual division method to be applied ²⁾ | | |
|-------------|-------------------------|------------|-------------------------------|--------|--|---------------------------------------|---|
| | Sampling | | Number of increments composed | CV (%) | Constant-mass division | Fixed-rate division | |
| | Method | Type | | | Increment division method | Riffle division and C/Q ³⁾ | |
| Increment | Manual | Mass-basis | | < 20 | × | × | |
| | | | | > 20 | × | — | |
| | Mechanical | Time-basis | | < 20 | × | × | |
| | | | | > 20 | × | — | |
| | | | — | × | | | |
| Subsample | Manual | Mass-basis | Equal | | × | × | |
| | | | | | × | × | |
| | Mechanical | Time-basis | | | Unequal | — | × |
| | | | | | — | — | × |

1) Any manual division method applies to the gross sample.

2) × denotes applicable, — denotes not applicable.

3) C/Q denotes coning and quartering method.

Web STANDARD PREVIEW
(standards.iteh.ai)

SIST ISO 3083:1998

<https://standards.iteh.ai/catalog/standards/sist/474daa41-f6fe-46ce-8106-0024c8fab8c/sist-iso-3083-1998>

6.7 Mixing

By mixing the sample thoroughly, it may be made homogeneous and consequently the errors in sample division can be lessened.

The mixing may be conducted either by a mechanical mixer or by hand. The mixer shall be selected to suit the sample and its particle size.

6.8 Pre-drying

When the sample is very wet or sticky and sample preparation cannot be carried out, the sample may be pre-dried in air or in an oven or similar device, below the temperature at which there is likely to be a change in quality, so that sample preparation may then be carried out without difficulty. If necessary, the pre-drying should be carried out according to the method in annex A to ISO 3087.

6.9 Requirements for sample preparation

6.9.1 Sample preparation shall be carried out in such a manner that there will be no contamination or introduction of materials other than the sample and no change of its quality. In particular, the moisture sample shall be kept in an airtight, non-absorbent container in order to avoid any change in its moisture content.

6.9.2 Check experiments for precision and bias shall be carried out from time to time on the sample preparation process, so that significant errors in the results caused by the process may be detected.

7 Apparatus

The following apparatus, which shall be thoroughly cleaned and examined before and after use, shall be provided for sample preparation.

7.1 Crushers and grinders.

7.2 **Drying ovens**, capable of regulating the temperature at any point in the oven to within ± 5 °C of the desired temperature.

7.3 Mixers.

7.4 **Riffle dividers**, details of which are given in annex A.

7.5 **Scoop**, for increment division, details of which are given in figure 1.

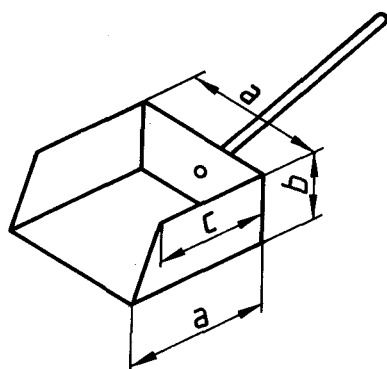

Figure 1 — Scoop for increment division and its dimensions

| Scoop number | Dimensions of scoop (mm) | | | Thickness of metal sheet (mm) | Volume (approx.) (ml) |
|--------------|--------------------------|----|----|-------------------------------|-----------------------|
| | a | b | c | | |
| 31,5 D | 90 | 60 | 80 | 2 | 450 |
| 22,4 D | 80 | 45 | 70 | 2 | 270 |
| 16 D | 70 | 40 | 60 | 2 | 180 |
| 10 D | 60 | 35 | 50 | 1 | 110 |
| 5 D | 50 | 30 | 40 | 1 | 65 |
| 2,8 D | 40 | 25 | 30 | 0,5 | 35 |
| 1 D | 30 | 15 | 25 | 0,5 | 10 |
| 0,5 D | 20 | 10 | 20 | 0,5 | 4 |
| 0,25 D | 15 | 10 | 12 | 0,3 | 2 |
| 0,1 D | 10 | 10 | 10 | 0,3 | 1 |

8 Combining increments for sample preparation

The method of combining increments shall be selected according to the types of sampling employed for taking increments, viz. whether the increments have been taken on mass-basis sampling or on time-basis sampling. Systematic sampling is classified into two types, viz. mass basis and time basis. Stratified and two-stage samplings are performed on the mass basis.

8.1 Combining increments taken by mass-basis sampling

8.1.1 Composition of subsamples or gross sample from increments

8.1.1.1 When the variation in mass of individual increments is under 20 % ($CV < 20\%$), the increments either as taken or after having been prepared individually by the constant-mass or fixed-rate division at an appropriate stage shall be combined into subsamples or the gross sample.

8.1.1.2 When the variation in mass of individual increments is 20 % or over ($CV > 20\%$), the increments as they are taken shall not be combined into subsamples or the gross sample.

The increments prepared after having been divided individually by the constant-mass division at a practical stage should be combined into subsamples or the gross sample at an appropriate stage (see table 1). Otherwise, each increment should be prepared into a test sample to be subjected to the determination of quality characteristics.

8.1.2 Composition of gross sample from subsamples

The subsamples composed according to 8.1.1 should, with or without division, be combined into the gross sample.

When division is carried out on each subsample to compose the gross sample, the division shall be carried out as follows:

- if the subsamples consist of an equal number of increments, constant-mass or fixed-rate division may be applied;
- if the subsamples consist of different numbers of increments, only the fixed-rate division shall be applied.

8.2 Combining increments taken by time-basis sampling

8.2.1 Composition of subsamples or gross sample from increments

8.2.1.1 The increments as they are taken should be combined into subsamples or the gross sample, irrespective of the variation in mass of increments.

8.2.1.2 When division is carried out on each increment and the divided increments are combined into subsamples or the gross sample, the division shall be carried out on each increment by the fixed-rate division at any stage (see table 1).

8.2.2 Composition of gross sample from subsamples

8.2.2.1 The subsamples composed according to 8.2.1 should, with or without division, be combined into the gross sample, irrespective of the variation in mass of subsamples.

8.2.2.2 When division is carried out on each subsample and the divided subsamples are combined into the gross sample, the division shall be carried out on each subsample by the fixed-rate division at any stage (see table 1).

9 Manual method of division

The manual method of division shall be applied to ores of minus 31,5 mm in whole-through sieve size. However, the coning and quartering method is not applicable, except on ores of minus 10 mm in whole-through sieve size. In that case 9.3 shall apply.