



Designation: **A265—09 A265 – 12**

Standard Specification for Nickel and Nickel-Base Alloy-Clad Steel Plate¹

This standard is issued under the fixed designation A265; the number immediately following the designation indicates the year of original adoption or, in the case of revision, the year of last revision. A number in parentheses indicates the year of last reappraisal. A superscript epsilon (ϵ) indicates an editorial change since the last revision or reappraisal.

This standard has been approved for use by agencies of the Department of Defense.

1. Scope*

1.1 This specification² covers plate of a carbon steel or low-alloy steel base to which is integrally and continuously bonded on one or both sides a layer of nickel or nickel-base alloy. The material is generally intended for pressure vessel use but may be used in other structural applications where corrosion resistance of the alloy is of prime importance.

1.2 The values stated in inch-pound units are to be regarded as standard. The values given in parentheses are mathematical conversions to SI units that are provided for information only and are not considered standard.

2. Referenced Documents

2.1 ASTM Standards:³

[A6/A6M Specification for General Requirements for Rolled Structural Steel Bars, Plates, Shapes, and Sheet Piling](#)

[A20/A20M Specification for General Requirements for Steel Plates for Pressure Vessels](#)

[A370 Test Methods and Definitions for Mechanical Testing of Steel Products](#)

[A578/A578M Specification for Straight-Beam Ultrasonic Examination of Rolled Steel Plates for Special Applications](#)

[A751 Test Methods, Practices, and Terminology for Chemical Analysis of Steel Products](#)

[B127 Specification for Nickel-Copper Alloy \(UNS N04400\) Plate, Sheet, and Strip](#)

[B162 Specification for Nickel Plate, Sheet, and Strip](#)

[B168 Specification for Nickel-Chromium-Iron Alloys \(UNS N06600, N06601, N06603, N06690, N06693, N06025, N06045, and N06696\), Nickel-Chromium-Cobalt-Molybdenum Alloy \(UNS N06617\), and Nickel-Iron-Chromium-Tungsten Alloy \(UNS N06674\) Plate, Sheet, and Strip](#)

[B333 Specification for Nickel-Molybdenum Alloy Plate, Sheet, and Strip](#)

[B409 Specification for Nickel-Iron-Chromium Alloy Plate, Sheet, and Strip](#)

[B424 Specification for Ni-Fe-Cr-Mo-Cu Alloy \(UNS N08825, UNS N08221, and UNS N06845\) Plate, Sheet, and Strip](#)

[B443 Specification for Nickel-Chromium-Molybdenum-Columbium Alloy \(UNS N06625\) and Nickel-Chromium-Molybdenum-Silicon Alloy \(UNS N06219\) Plate, Sheet, and Strip](#)

[B463 Specification for UNS N08020 Alloy Plate, Sheet, and Strip](#)

[B575 Specification for Low-Carbon Nickel-Chromium-Molybdenum, Low-Carbon Nickel-Chromium-Molybdenum-Copper, Low-Carbon Nickel-Chromium-Molybdenum-Tantalum, and Low-Carbon Nickel-Chromium-Molybdenum-Tungsten Alloy Plate, Sheet, and Strip](#)

[B582 Specification for Nickel-Chromium-Iron-Molybdenum-Copper Alloy Plate, Sheet, and Strip](#)

[B625 Specification for UNS N08925, UNS N08031, UNS N08932, UNS N08926, UNS N08354, and UNS R20033 Plate, Sheet, and Strip](#)

2.2 Other Standards:

[ASME Code Boiler and Pressure Vessel Code, Section IX, Welding Qualifications](#)⁴

¹ This specification is under the jurisdiction of ASTM Committee A01 on Steel, Stainless Steel and Related Alloys and is the direct responsibility of Subcommittee A01.11 on Steel Plates for Boilers and Pressure Vessels.

Current edition approved May 1, 2009; Nov. 1, 2012. Published June 2009; November 2012. Originally approved in 1943. Last previous edition approved in 2003 as A265 – 03; A265 – 09. DOI: 10.1520/A0265-09.10.1520/A0265-12.

² For ASME Boiler and Pressure Vessel Code applications see related Specification SA-265 in Section II of that Code.

³ For referenced ASTM standards, visit the ASTM website, www.astm.org, or contact ASTM Customer Service at service@astm.org. For *Annual Book of ASTM Standards* volume information, refer to the standard's Document Summary page on the ASTM website.

⁴ Available from American Society of Mechanical Engineers (ASME), ASME International Headquarters, Three Park Ave., New York, NY 10016-5990, <http://www.asme.org>.

*A Summary of Changes section appears at the end of this standard

3. Terminology

3.1 Definitions of Terms Specific to This Standard:

3.1.1 This material is considered as single-clad or double-clad nickel or nickel-base alloy clad steel plate, depending on whether one or both sides are covered.

3.1.2 The term plate as used in this specification applies to material $\frac{3}{16}$ in. (2.73 mm) and over in thickness, and over 10 in. (254 mm) in width.

3.1.3 *alloy cladding*—the nickel or nickel-base alloy component of the composite plate.

3.1.4 *base metal (backing steel)*—component to which the alloy cladding is applied, usually the greater percentage of the composite plate and usually consisting of carbon or low-alloy steel.

3.1.5 *integrally and continuously bonded*—the process by which the alloy cladding and base metal are brought together to form a metallurgical bond at essentially the entire interface of the two metals by means other than those processes that do not produce a homogeneous composite plate.

4. Ordering Information

4.1 It is the responsibility of the purchaser to specify all requirements that are necessary for material ordered under this specification. Such requirements may include, but are not limited to the following:

4.1.1 Quantity (weight or number of pieces).

4.1.2 Heat treatment, if required (see Section 5).

4.1.3 Dimensions, including the thickness of the cladding alloy and the backing steel, or of the total composite plate and if more or less restrictive thickness tolerances apply.

4.1.4 Cladding alloy specification (see Section 6).

4.1.5 Base metal specification (see Section 6).

4.1.6 Product analysis, if required. Specify whether applicable to the cladding alloy, backing steel, or both (see Section 10).

4.1.7 Mechanical Properties (see Sections 7, 13, and 14).

4.1.8 Restrictions, if required, on repair by welding (see Section 14).

4.1.9 Additions to the specification or special requirements. requirements such as applicable construction code rules.

4.1.10 Corrosions tests, if required.

4.1.11 Notification when the cladding alloy is to be used for inclusion in the design strength calculations for an applicable construction code.

NOTE 1—Construction codes may dictate certain fabrication requirements when the cladding is used in the design calculations that may be different than if the cladding is used for corrosion resistance only. This may be particularly important when the alloy cladding involves the use of welded components in the explosion bonded clad manufacturing process. It is incumbent on the purchaser to make the clad manufacturer aware of any such restrictions or applications at time of order.

4.2 In addition to the basic requirements of this specification and the backing steel specification, certain supplementary requirements are available when necessary to meet the additional control, testing, or examination is required to meet end use requirements. These include: The purchaser is referred to the listed supplementary requirements in this specification and to the detailed requirements in Specification A20/A20M.

4.2.1 Nondestructive examination,

4.2.2 Impact testing, and

4.2.3 Simulated Post-Weld Heat Treatment of Mechanical Test Coupons (SPWHT).

4.3 The purchaser is referred to the listed supplementary requirements in this specification and to the detailed requirements in Specification A20/A20M. If the requirements of this specification are in conflict with the requirements of Specification A20/A20M, the requirements of this specification shall prevail.

4.4 Special tests.

5. Materials and Manufacture

5.1 Process:

5.1.1 The steel shall be made by the open-hearth, electric-furnace (with separate degassing and refining optional), or basic-oxygen processes, or by secondary processes whereby steel made from these primary processes is remelted using, but not limited to electroslag remelting or vacuum arc remelting processes.

5.1.2 The cladding metal may be metallurgically bonded to the base metal by any method that will produce a clad steel that will conform to the requirements of this specification.

5.1.3 For explosively bonded products, the alloy cladding metal may be comprised of two or more separate alloy plates or sheets completely welded together to form a single fabricated component.

5.2 *Heat Treatment*—Unless a specific heat treatment is required by the cladding material or base steel specification, or unless otherwise agreed upon by the purchaser and manufacturer, the clad plate shall be furnished in a condition that is appropriate for the cladding alloy, base metal, or both.

TABLE 1 Weights for Component Materials

	Density		Weight per Square Foot for Material 1 in. (25.4 mm) in Thickness, lb
	lb/in. ³	g/cm ³	
Steel	0.283	7.83	40.80
Nickel	0.321	8.88	46.22
Nickel-copper alloy	0.319	8.83	45.94
Nickel-chromium-iron alloy	0.307	8.49	44.21

6. Chemical Composition

6.1 The composite plate may conform to any desired combination cladding metal and base metal as described in 6.2 and 6.3, and as agreed upon between the purchaser and the manufacturer.

6.2 *Cladding Metal*—The nickel or nickel-base alloy cladding metal specified shall conform to the requirements as to chemical composition prescribed for the respective metal in Specifications B127, B162, B168, B333, B409, B424, B443, B463, B575, B582, and B625, or other nickel-base alloy as agreed upon by the purchaser and manufacturer.

6.3 *Base Metal*—The base metal shall be carbon steel or low-alloy steel conforming to the ASTM specifications for steels for either pressure vessels or general structural applications, or other, as agreed upon by the purchaser and manufacturer. The base metal shall conform to the chemical requirements of the specification to which it is ordered.

7. Mechanical Properties

7.1 Tensile Requirements:

7.1.1 The tensile properties shall be determined by a tension test of the composite plate for clad plates that meet all of the following conditions.

- (1) The nominal composite gage is less than or equal to 1½ in (38 mm).
- (2) The specified minimum tensile strength of the base steel is less than or equal to 70 000 psi (485 MPa).
- (3) The specified minimum yield strength of the base steel is less than or equal to 40 000 psi (275 MPa).
- (4) The tensile properties thus determined shall not be less than the minimum and not more than 5000 psi (35 MPa) over the maximum prescribed in the specification for the base steel used. All other tensile test requirements of the specification for the base steel shall be met.

7.1.2 The tensile properties shall be determined by a tension test of the base steel only for clad plates that meet one of the following conditions. The properties thus determined shall meet all of the tensile test requirements for the base steel.

- (1) The composite gage is greater than 1½ in. (38 mm).
- (2) The specified minimum tensile strength of the base steel is greater than 70 000 psi (485 MPa).
- (3) The specified minimum yield strength of the base steel is greater than 40 000 psi (275 MPa).

7.1.3 If the cladding is for corrosion allowance only, the cladding need not be included in the tensile test. The tensile properties thus determined shall meet the base steel requirements.

7.2 Test for strength of the bond, when required, must be specified by the purchaser and shall consist of one of the following.

7.2.1 *Shear Strength*—When required by the purchaser, the minimum shear strength of the alloy cladding and base metals shall be 20 000 psi (140 MPa). The shear test, when specified, shall be made in the manner indicated in Fig. 1. The minimum cladding thickness for shear testing shall be 0.075 in. (1.9 mm) exclusive as ordered. Testing for shear strength for clad plates with minimum cladding thickness of 0.075 in (1.9 mm) or less shall be permitted upon agreement between the purchaser and the manufacturer.

7.2.2 *Bond Strength*—As an alternative to the shear strength test provided in 7.2.1 or when agreed upon by the purchaser and the manufacturer, or both, three bend tests shall be made with the alloy cladding in compression to determine the quality of the bond. These bend tests shall be made in the manner of the tension tests indicated in Fig. 2 and shall be bent through an angle of 180° to the bend diameters provided for in either Specification A6/A6M or Specification A20/A20M (Appendix X4, or equivalent), as applicable. At least two of the three tests shall show not more than 50 % separation on both edges of the bent portion. Greater separation shall be cause for rejection.

7.3 Methods and practices relating to mechanical testing required by this specification shall be in accordance with the Test Methods and Definitions of A370.

8. Number of Tests and Retests

8.1 One or more tension tests, as required by the specifications for the base metal and when specified, one shear test or three bond bend tests shall be made, representing each plate as rolled. Each specimen shall be in the final condition of heat treatment required for the plate, including any SPWHT if required.

8.2 If any test specimen shows defective machining or develops flaws, it may be discarded and another specimen substituted.

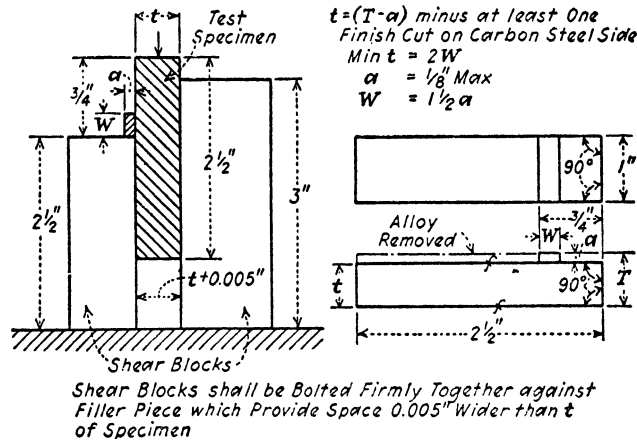

Metric Equivalents			
in.	mm	in.	mm
0.005	0.127	1	25.4
1/8	3.17	2 1/2	64.5
3/4	19.1	3	76.2

FIG. 1 Test Specimen and Method of Making Shear Test of Clad Plate

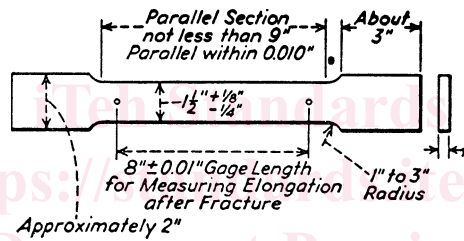

Metric Equivalents			
in.	mm	in.	mm
0.01	0.254	1 1/2	38.1
1/8	3.17	2	50.8
1/4	6.35	3	76.2
1	25.4	8	203.2

- NOTE 1—When necessary, it is permissible to use a narrower specimen, but in such a case the reduced portion shall be not less than 1 in. in width.
- NOTE 2—Punch marks for measuring elongation after fracture shall be made on the flat or on the edge of the specimen and within the parallel section; either a set of nine punch marks 1 in. apart, or one or more sets of 8-in. punch marks may be used.
- NOTE 3—The dimension *t* is the thickness of the test specimen as provided for in the applicable material specifications.

FIG. 2 Standard Rectangular Test Specimens with 8-in. Gage Length

9. Test Specimens

- 9.1 The tension test specimens shall conform to the requirements prescribed in the specifications for the base metal.
- 9.2 Bend test specimens for the alternative bond strength tests shall be taken at right angles to its longitudinal axis.
- 9.3 When required by the purchaser, the shear test specimen shall be taken near a top or bottom corner of the plate as rolled, parallel to its longitudinal axis, or other location that is representative of the final product.
- 9.4 For plates 1 1/2 in. (38 mm) and under in thickness, tension test specimens shall be the full thickness of the material, except as specified in 7.1.2 and 7.1.3.
- 9.5 For plates over 1 1/2 in. (38 mm) in thickness, tension tests shall be of the form shown in Fig. 3 and shall be of all base steel conforming to the requirements of the specification for the base steel.
- 9.6 The bend test specimen used for bond strength determination shall be 1 1/2 in. (38 mm) by not more than 3/4 in. (19 mm) in thickness and shall be machined to the form and dimensions shown in Fig. 2, or may be machined with both edges parallel. In reducing the thickness of the specimen, both the alloy cladding and the base steel shall be machined so as to maintain the same ratio of clad metal to base steel as is maintained in the plate, except that the thickness of the clad material need not be reduced