



SLOVENSKI STANDARD
SIST ISO 3084:2000
01-junij-2000

Železove rude - Eksperimentalne metode za vrednotenje spremembe kakovosti

Iron ores -- Experimental methods for evaluation of quality variation

Minerais de fer -- Méthodes expérimentales pour l'évaluation de la variation de qualité

Ta slovenski standard je istoveten z: ISO 3084:1998

[SIST ISO 3084:2000](https://standards.iteh.ai/catalog/standards/sist/520c963a-d9ad-42f4-bce9-311b928a7856/sist-iso-3084-2000)

<https://standards.iteh.ai/catalog/standards/sist/520c963a-d9ad-42f4-bce9-311b928a7856/sist-iso-3084-2000>

ICS:

73.060.10 Železove rude Iron ores

SIST ISO 3084:2000 **en**

iTeh STANDARD PREVIEW
(standards.iteh.ai)

SIST ISO 3084:2000

<https://standards.iteh.ai/catalog/standards/sist/520c963a-d9ad-42f4-bce9-311b928a7856/sist-iso-3084-2000>

INTERNATIONAL STANDARD

**ISO
3084**

Third edition
1998-12-15

Iron ores — Experimental methods for evaluation of quality variation

*Minerais de fer — Méthodes expérimentales pour l'évaluation de la
variation de qualité*

iTeh STANDARD PREVIEW
(standards.iteh.ai)

[SIST ISO 3084:2000](https://standards.iteh.ai/catalog/standards/sist/520c963a-d9ad-42f4-bce9-311b928a7856/sist-iso-3084-2000)

<https://standards.iteh.ai/catalog/standards/sist/520c963a-d9ad-42f4-bce9-311b928a7856/sist-iso-3084-2000>



Reference number
ISO 3084:1998(E)

ISO 3084:1998(E)

Contents

1 Scope	1
2 Normative references	1
3 Definitions	1
4 General conditions	2
5 Evaluation of quality variation using interleaved sampling	2
6 Estimation of quality variation from the variogram.....	8
7 Classification of quality variation	10
Annex A (informative) Examples for calculations of standard deviation	12

iTeh STANDARD PREVIEW
(standards.iteh.ai)

SIST ISO 3084:2000

<https://standards.iteh.ai/catalog/standards/sist/520c963a-d9ad-42f4-bce9-311b928a7856/sist-iso-3084-2000>

© ISO 1998

All rights reserved. Unless otherwise specified, no part of this publication may be reproduced or utilized in any form or by any means, electronic or mechanical, including photocopying and microfilm, without permission in writing from the publisher.

International Organization for Standardization
Case postale 56 • CH-1211 Genève 20 • Switzerland
Internet iso@iso.ch

Printed in Switzerland

Foreword

ISO (the International Organization for Standardization) is a worldwide federation of national standards bodies (ISO member bodies). The work of preparing International Standards is normally carried out through ISO technical committees. Each member body interested in a subject for which a technical committee has been established has the right to be represented on that committee. International organizations, governmental and non-governmental, in liaison with ISO, also take part in the work. ISO collaborates closely with the International Electrotechnical Commission (IEC) on all matters of electrotechnical standardization.

Draft International Standards adopted by the technical committees are circulated to the member bodies for voting. Publication as an International Standard requires approval by at least 75 % of the member bodies casting a vote.

International Standard ISO 3084 was prepared by Technical Committee ISO/TC 102, *Iron ores*, subcommittee SC 1, *Sampling*.

This third edition cancels and replaces the second edition (ISO 3084:1986) which has been technically revised.

Annex A of this International Standard is for information only.

iTeh STANDARD PREVIEW (standards.iteh.ai)

[SIST ISO 3084:2000](https://standards.iteh.ai/catalog/standards/sist/520c963a-d9ad-42f4-bce9-311b928a7856/sist-iso-3084-2000)

<https://standards.iteh.ai/catalog/standards/sist/520c963a-d9ad-42f4-bce9-311b928a7856/sist-iso-3084-2000>

iTeh STANDARD PREVIEW
(standards.iteh.ai)

SIST ISO 3084:2000

<https://standards.iteh.ai/catalog/standards/sist/520c963a-d9ad-42f4-bce9-311b928a7856/sist-iso-3084-2000>

Iron ores — Experimental methods for evaluation of quality variation

1 Scope

This International Standard specifies experimental methods for the evaluation of quality variation of iron ores for each type of iron ore being traded and for each handling plant.

Two distinct approaches are specified. The first is to analyse interleaved samples composed of a number of paired increments taken and combined alternately following stratified sampling or systematic sampling as specified in ISO 3082. The second is to collect and analyse individual increments and then to analyse the data using variographic methods.

Using interleaved samples involves less work, but use of variograms provides a better estimate of quality variation and hence a better estimate of the sampling variance. The variogram method is usually used to fine tune a sampling operation.

NOTE The experimental methods may be applied approximately to time basis sampling when the flowrate is almost uniform.

iTeh STANDARD PREVIEW
(standards.iteh.ai)

2 Normative references

SIST ISO 3084:2000

<https://standards.iteh.ai/catalog/standards/sist/520c963a-d9ad-42f4-bce9-21859971285c/iso-3084-2000>

The following standards contain provisions which, through reference in this text, constitute provisions of this International Standard. At the time of publication, the editions indicated were valid. All standards are subject to revision, and parties to agreements based on this International Standard are encouraged to investigate the possibility of applying the most recent editions of the standards indicated below. Members of IEC and ISO maintain registers of currently valid International Standards.

ISO 3082:—¹⁾, *Iron ores — Sampling and sample preparation procedures*.

ISO 3085:1996, *Iron ores — Experimental methods for checking the precision of sampling*.

ISO 11323:1996, *Iron ores — Vocabulary*.

3 Definitions

For the purposes of this International Standard, the definitions given in ISO 11323 and the following apply.

3.1 interleaved samples

samples constituted by placing consecutive primary increments alternately into two sample containers

¹⁾ To be published. (Revision of ISO 3081:1986, ISO 3082:1987 and ISO 3083:1986)

4 General conditions

4.1 Quality variation

The quality variation or degree of heterogeneity of iron ore shall be determined in terms of the standard deviation.

The standard deviation of a quality characteristic between increments taken from within strata, denoted by σ_w , shall be determined either by estimating the variance between interleaved samples or by measuring individual increments and determining the slope and intercept of a linear fit to a variogram corrected by subtraction of sample preparation and measurement variances. In both cases, where corrections for sample preparation and measurement variances are made (see 5.6.2, note 2, and 6.1), it is essential that the sample preparation and measurement variances be determined at the same time as the experiments to determine quality variation are carried out.

4.2 Quality characteristics

The quality characteristic chosen for determining the quality variation is generally the total iron content, but silica content, alumina content, moisture content, size distribution and other quality characteristics may also be chosen.

When separate samples are taken for the determination of chemical composition, moisture content, size distribution, etc., the quality variation for the individual characteristics shall be adopted. When the sample is used for the determination of more than one quality characteristic, the largest classification category for quality variation among these characteristics shall be adopted.

4.3 Sampling, sample preparation and measurement

Sampling and sample preparation shall be carried out in accordance with ISO 3082. Measurement of samples shall be carried out in accordance with the relevant international Standards for chemical analysis, moisture content and size analysis of iron ores.

SIST ISO 3084:2000

The sampling for evaluation of quality variation may be conducted in conjunction with routine sampling for determination of the quality of the lot. In other words, the samples collected from the lot may be used for both purposes.

5 Evaluation of quality variation using interleaved sampling

5.1 General

The procedures for evaluating the standard deviation within strata, σ_w , applicable to both stratified and systematic sampling, are described in 5.2 to 5.7.

5.2 Type of investigation

5.2.1 Type 1

When lots are frequently delivered, the quality variation may be determined from a large number of lots of almost equal mass as follows:

- a) treat each lot separately;
- b) make up a pair of interleaved samples for each lot as shown in figure 1a) and example 1.

5.2.2 Type 2

When large lots are infrequently delivered, the quality variation may be determined from a single lot as follows:

- a) split the lot into at least 10 parts of almost equal mass;
- b) make up a pair of interleaved samples for each part by combining the increments taken from each part as shown in figure 1b) and example 2.

5.2.3 Type 3

When small lots are frequently delivered, the quality variation may be determined from several lots of almost equal mass as follows:

- a) split all the lots involved into at least 10 parts of almost equal mass;
- b) make up a pair of interleaved samples for each part by combining the increments taken from each part as shown in figure 1c) and example 3.

5.2.4 Type 4

When sampling a wagon-borne lot and when increments are taken from all wagons comprising the lot, the sampling scheme may be regarded as stratified sampling. When lots are frequently delivered, the procedure for determining quality variation is as follows:

- a) treat each lot separately;
- b) make up a pair of interleaved samples for each lot as shown in figure 1d).

iTeh STANDARD PREVIEW
(standards.iteh.ai)

5.3 Number of increments and constitution of interleaved samples

5.3.1 Number of increments

<https://standards.iteh.ai/catalog/standards/sist/520c963a-d9ad-42f4-bce9-311b928a7856/sist-iso-3084-2000>

The number of increments to be taken from one or several lots may be the same as that selected for routine sampling. However, when the routine sampling is based on the classification category of "small" quality variation and the number of increments is considered to be insufficient to obtain a reliable standard deviation, then the number of increments shall be increased (see ISO 3082).

5.3.1.1 Type 1 investigation

For type 1 investigations, the number of increments, n_1 , to be taken from each lot shall be in accordance with ISO 3082, and a pair of interleaved samples shall be constituted for each lot [see figure 1a)].

5.3.1.2 Type 2 investigation

For type 2 investigations, the number of increments, n_1 , shall be determined from ISO 3082, and at least 10 pairs of interleaved samples shall be constituted [see figure 1b)].

5.3.1.3 Type 3 investigation

For type 3 investigations, the number of increments, n_1 , to be taken from each lot shall be in accordance with ISO 3082. Each lot shall be divided into a number of strata, and increments from each stratum shall be combined into a pair of interleaved samples [see figure 1c)].

5.3.1.4 Type 4 investigation

For type 4 investigations, the number of increments, n_1 , being collected from each lot shall be determined from table 3 of ISO 3082, and the number of increments, n_w , to be taken from each wagon shall be in accordance with

ISO 3082. If the number is odd, it shall be increased by one to make it even. A pair of interleaved samples shall be constituted for each lot [see figure 1d)].

5.3.2 Constitution of interleaved samples

The interleaved samples shall be made up according to the following procedure:

- allocate a serial number to the increments from each lot or part-lot in order of sampling;
- constitute pairs of interleaved samples from consecutive odd-numbered increments (denoted by interleaved sample A_i) and consecutive even-numbered increments (denoted by interleaved sample B_i) for each lot or part-lot (see figure 2);
- for each investigation, prepare n sets of paired interleaved samples.

Each interleaved sample shall be made up of two or more increments.

5.4 Preparation of test samples and measurement

Separate test samples shall be prepared from the interleaved samples, A_i and B_i .

Chemical analysis, moisture determination, size determination or physical testing shall be carried out on the test samples as required.

iTeh STANDARD PREVIEW
(standards.iteh.ai)

[SIST ISO 3084:2000](https://standards.iteh.ai/catalog/standards/sist/520c963a-d9ad-42f4-bce9-311b928a7856/sist-iso-3084-2000)

<https://standards.iteh.ai/catalog/standards/sist/520c963a-d9ad-42f4-bce9-311b928a7856/sist-iso-3084-2000>

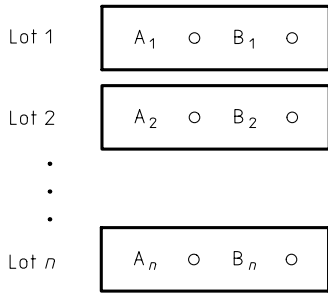

a) Type 1 investigation — n lots: one lot = one part

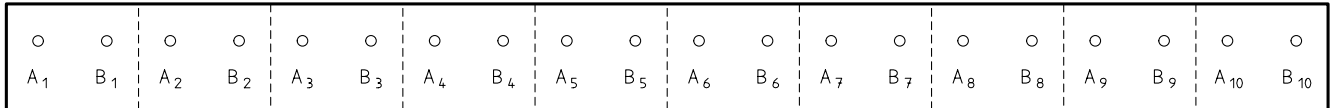

Key: The rectangular box indicates one lot; each division of the box made by broken lines indicates one part; a pair of circles indicates a pair of interleaved samples. This also applies to a) and c).

b) Type 2 investigation — One lot (example for 10 parts)

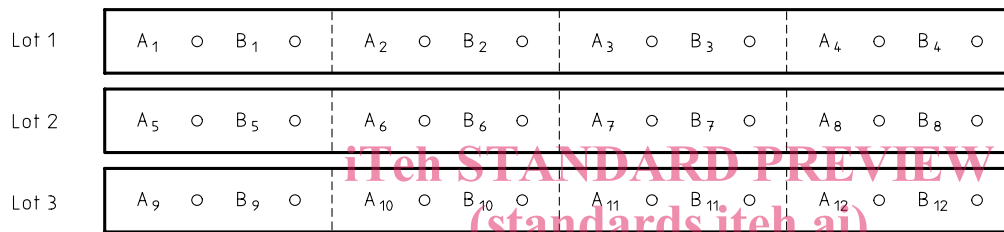

ITeH STANDARD PREVIEW
(standards.iteh.ai)

c) Type 3 investigation — Several lots (example for three lots and 12 parts)

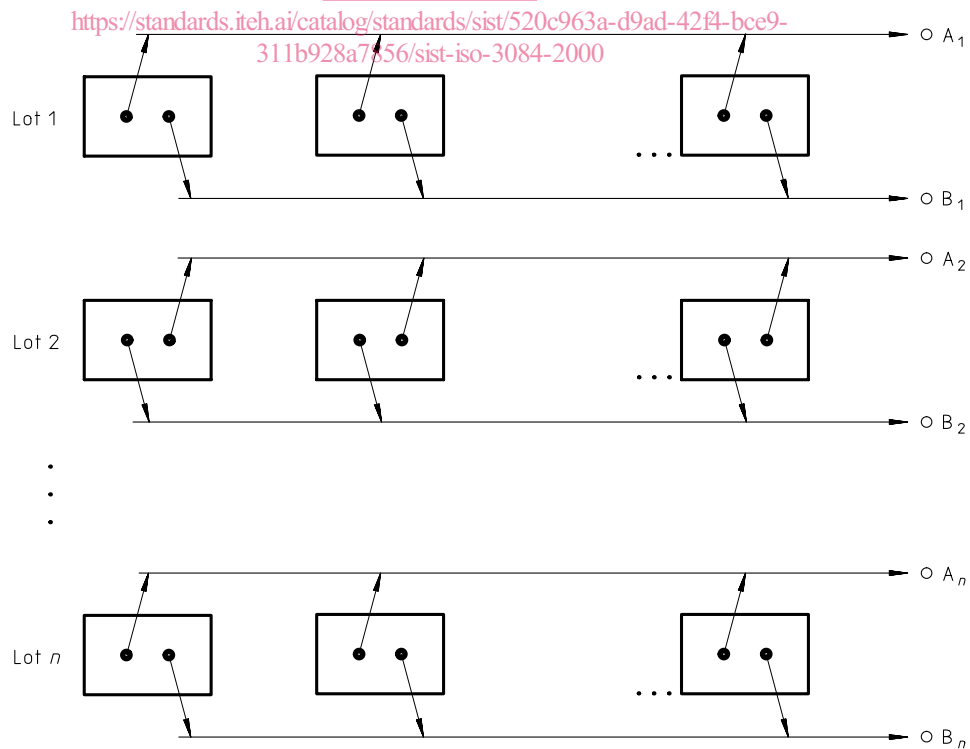

Key: Each box indicates a wagon; points in the box indicate increments; circles indicate interleaved samples.

d) Type 4 investigation — Stratified sampling of wagon-borne lots.