

FINAL
DRAFT

INTERNATIONAL
STANDARD

ISO/FDIS
19085-6

ISO/TC 39/SC 4

Secretariat: UNI

Voting begins on:
2023-12-07

Voting terminates on:
2024-02-01

Woodworking machines — Safety — Part 6: Single spindle vertical moulding machines (toupie)

Machines à bois — Sécurité —

Partie 6: Toupies monobroches à arbre vertical

ITeH Standards
(<https://standards.iteh.ai>)
Document Preview

[ISO/FDIS 19085-6](#)

<https://standards.iteh.ai/catalog/standards/sist/e30536dc-0137-4db7-86d4-37c86e94d7fc/iso-fdis-19085-6>

ISO/CEN PARALLEL PROCESSING

RECIPIENTS OF THIS DRAFT ARE INVITED TO SUBMIT, WITH THEIR COMMENTS, NOTIFICATION OF ANY RELEVANT PATENT RIGHTS OF WHICH THEY ARE AWARE AND TO PROVIDE SUPPORTING DOCUMENTATION.

IN ADDITION TO THEIR EVALUATION AS BEING ACCEPTABLE FOR INDUSTRIAL, TECHNOLOGICAL, COMMERCIAL AND USER PURPOSES, DRAFT INTERNATIONAL STANDARDS MAY ON OCCASION HAVE TO BE CONSIDERED IN THE LIGHT OF THEIR POTENTIAL TO BECOME STANDARDS TO WHICH REFERENCE MAY BE MADE IN NATIONAL REGULATIONS.



Reference number
ISO/FDIS 19085-6:2023(E)

© ISO 2023

iTeh Standards
(<https://standards.iteh.ai>)
Document Preview

[ISO/FDIS 19085-6](https://standards.iteh.ai/catalog/standards/sist/e30536dc-0137-4db7-86d4-37c86e94d7fc/iso-fdis-19085-6)

<https://standards.iteh.ai/catalog/standards/sist/e30536dc-0137-4db7-86d4-37c86e94d7fc/iso-fdis-19085-6>



COPYRIGHT PROTECTED DOCUMENT

© ISO 2023

All rights reserved. Unless otherwise specified, or required in the context of its implementation, no part of this publication may be reproduced or utilized otherwise in any form or by any means, electronic or mechanical, including photocopying, or posting on the internet or an intranet, without prior written permission. Permission can be requested from either ISO at the address below or ISO's member body in the country of the requester.

ISO copyright office
CP 401 • Ch. de Blandonnet 8
CH-1214 Vernier, Geneva
Phone: +41 22 749 01 11
Email: copyright@iso.org
Website: www.iso.org

Published in Switzerland

Contents

Page

Foreword	vi
Introduction	vii
1 Scope	1
2 Normative references	2
3 Terms and definitions	2
4 Safety requirements and measures for controls	9
4.1 Safety and reliability of control systems.....	9
4.2 Control devices.....	9
4.3 Start.....	10
4.3.1 Direct start.....	10
4.3.2 Start via control power-on.....	11
4.4 Safe stops.....	11
4.4.1 General.....	11
4.4.2 Normal stop.....	11
4.4.3 Operational stop.....	11
4.4.4 Emergency stop.....	11
4.5 Braking function of tools.....	11
4.6 Mode selection.....	11
4.7 Tool speed changing.....	11
4.7.1 Speed changing by shifting the belts on the pulleys.....	11
4.7.2 Speed changing by incremental speed change motor.....	11
4.7.3 Infinitely variable speed by frequency inverter.....	11
4.7.4 Speed limiting device for tenoning.....	11
4.7.5 Changing of the direction of tool rotation.....	12
4.8 Failure of any power supply.....	13
4.9 Manual reset control.....	13
4.10 Standstill detection and monitoring.....	13
4.11 Machine moving parts speed monitoring.....	13
4.12 Time delay.....	13
4.13 Teleservice.....	13
4.14 Power-driven adjustment of arbor, demountable power feed unit, fences and table insert.....	13
5 Safety requirements and measures for protection against mechanical hazards	14
5.1 Stability.....	14
5.2 Risk of break-up during operation.....	14
5.3 Tool and tool fixing design.....	14
5.3.1 General.....	14
5.3.2 Spindle locking.....	17
5.3.3 Circular saw blade fixing device.....	17
5.3.4 Flange dimension for circular saw blades.....	17
5.3.5 Arbor rings.....	18
5.3.6 Quick tool/arbor change system.....	18
5.3.7 Manual adjustment of arbor height.....	18
5.3.8 Manual adjustment of arbor inclination.....	19
5.4 Braking.....	19
5.4.1 Braking of tools.....	19
5.4.2 Maximum run-down time.....	19
5.4.3 Brake release.....	19
5.5 Safeguards.....	20
5.5.1 Fixed guards.....	20
5.5.2 Interlocking movable guards.....	20
5.5.3 Hold-to-run control.....	20

5.5.4	Two-hand control.....	20
5.5.5	Electro-sensitive protective equipment (ESPE).....	20
5.5.6	Pressure-sensitive protective equipment (PSPE).....	20
5.5.7	Enabling control.....	20
5.6	Prevention of access to hazardous moving parts.....	20
5.6.1	Access to the tool below the table.....	20
5.6.2	Safeguarding for straight work.....	21
5.6.3	Safeguarding for curved work.....	23
5.6.4	Safeguarding for tenoning.....	23
5.6.5	Safeguarding the glass bead saw blade.....	24
5.6.6	Guarding of drives.....	24
5.7	Impact hazard.....	24
5.8	Clamping devices.....	24
5.9	Measures against ejection.....	25
5.9.1	General.....	25
5.9.2	Guards materials and characteristics.....	25
5.9.3	Anti-kickback devices.....	25
5.10	Workpiece supports and guides.....	28
5.10.1	Machine table.....	28
5.10.2	Workpiece guiding for straight work.....	31
5.10.3	Workpiece guiding for curved work.....	32
5.11	Safety appliances.....	33
6	Safety requirements and measures for protection against other hazards.....	33
6.1	Fire.....	33
6.2	Noise.....	33
6.2.1	Noise reduction at the design stage.....	33
6.2.2	Noise emission measurement and declaration.....	34
6.3	Emission of chips and dust.....	34
6.4	Electricity.....	34
6.5	Ergonomics and handling.....	34
6.6	Lighting.....	34
6.7	Pneumatics.....	34
6.8	Hydraulics.....	35
6.9	Electromagnetic compatibility.....	35
6.10	Laser.....	35
6.11	Static electricity.....	35
6.12	Errors of fitting.....	35
6.13	Isolation.....	35
6.14	Maintenance.....	35
6.15	Relevant but not significant hazards.....	35
7	Information for use.....	35
7.1	Warning devices.....	35
7.2	Marking.....	35
7.2.1	General.....	35
7.2.2	Additional markings.....	35
7.3	Instruction handbook.....	36
7.3.1	General.....	36
7.3.2	Additional information.....	36
	Annex A (informative) List of significant hazards.....	39
	Annex B (informative) Performance level required.....	41
	Annex C (normative) Stability test.....	42
	Annex D (normative) Test for braking function.....	43
	Annex E (normative) Impact test for guards.....	44
	Annex F (normative) Noise test code.....	45

Annex G (informative) Determination of maximum spindle speeds for single piece arbors	48
Annex H (normative) Rigidity test for pressure pads, hand protectors and guiding steadies	52
Annex ZA (informative) Relationship between this European Standard and the essential requirements of Directive 2006/42/EC aimed to be covered	59

iTeh Standards
(<https://standards.itih.ai>)
Document Preview

[ISO/FDIS 19085-6](https://standards.itih.ai/catalog/standards/sist/e30536dc-0137-4db7-86d4-37c86e94d7fc/iso-fdis-19085-6)

<https://standards.itih.ai/catalog/standards/sist/e30536dc-0137-4db7-86d4-37c86e94d7fc/iso-fdis-19085-6>

Foreword

ISO (the International Organization for Standardization) is a worldwide federation of national standards bodies (ISO member bodies). The work of preparing International Standards is normally carried out through ISO technical committees. Each member body interested in a subject for which a technical committee has been established has the right to be represented on that committee. International organizations, governmental and non-governmental, in liaison with ISO, also take part in the work. ISO collaborates closely with the International Electrotechnical Commission (IEC) on all matters of electrotechnical standardization.

The procedures used to develop this document and those intended for its further maintenance are described in the ISO/IEC Directives, Part 1. In particular, the different approval criteria needed for the different types of ISO document should be noted. This document was drafted in accordance with the editorial rules of the ISO/IEC Directives, Part 2 (see www.iso.org/directives).

ISO draws attention to the possibility that the implementation of this document may involve the use of (a) patent(s). ISO takes no position concerning the evidence, validity or applicability of any claimed patent rights in respect thereof. As of the date of publication of this document, ISO had not received notice of (a) patent(s) which may be required to implement this document. However, implementers are cautioned that this may not represent the latest information, which may be obtained from the patent database available at www.iso.org/patents. ISO shall not be held responsible for identifying any or all such patent rights.

Any trade name used in this document is information given for the convenience of users and does not constitute an endorsement.

For an explanation of the voluntary nature of standards, the meaning of ISO specific terms and expressions related to conformity assessment, as well as information about ISO's adherence to the World Trade Organization (WTO) principles in the Technical Barriers to Trade (TBT), see www.iso.org/iso/foreword.html.

This document was prepared by Technical Committee ISO/TC 39, *Machine tools*, Subcommittee SC 4 *Woodworking machines*, in collaboration with the European Committee for Standardization (CEN) Technical Committee CEN/TC 143, *Woodworking machines*, in accordance with the Agreement on technical cooperation between ISO and CEN (Vienna Agreement).

This second edition cancels and replaces the first edition (ISO 19085-6:2017), which has been technically revised. The main changes are as follows:

- the Scope now specifies that machines are intended for continuous production use;
- the list of significant hazards has been moved to [Annex A](#);
- the structure has been simplified and modified, in particular in [5.6](#);
- [Subclause 6.2](#) has been updated and a new full noise test code has been added in [Annex F](#).

A list of all parts in the ISO 19085 series can be found on the ISO website.

Any feedback or questions on this document should be directed to the user's national standards body. A complete listing of these bodies can be found at www.iso.org/members.html.

Introduction

The ISO 19085 series of International Standards provides technical safety requirements for the design and construction of woodworking machinery, as well as for the content of the relevant instruction handbook. It concerns designers, manufacturers, suppliers and importers of the machines specified in the Scope.

This document is a type-C standard as defined in ISO 12100.

This document is of relevance, in particular, for the following stakeholder groups representing the market players with regard to machinery safety:

- machine manufacturers (small, medium and large enterprises);
- health and safety bodies (regulators, accident prevention organisations, market surveillance etc.)

Others can be affected by the level of machinery safety achieved with the means of the document by the above-mentioned stakeholder groups:

- machine users/employers (small, medium and large enterprises);
- machine users/employees (e.g. trade unions, organizations for people with special needs);
- service providers, e. g. for maintenance (small, medium and large enterprises);
- consumers (in case of machinery intended for use by consumers).

The above-mentioned stakeholder groups have been given the possibility to participate in the drafting process of this document.

The machinery concerned and the extent to which hazards, hazardous situations or hazardous events are covered are indicated in the Scope of this document.

When requirements of this type-C standard are different from those which are stated in type-A or type-B standards (as defined in ISO 12100), the requirements of this type-C standard take precedence over the requirements of the other standards for machines that have been designed and built according to the requirements of this type-C standard.

The full set of requirements for a particular type of woodworking machine are those given in the part of ISO 19085 applicable to that type, together with the relevant requirements from ISO 19085-1:2021, to the extent specified in the Scope of the applicable part of ISO 19085.

As far as possible, the safety requirements of parts of the ISO 19085 series refer to the relevant clauses of ISO 19085-1. Each part includes replacements and additions to the common requirements given in ISO 19085-1.

All parts of the ISO 19085 series have the same structure, so that reference to ISO 19085-1 is made always and only from and to the same subclause number, last indent.

[Clauses 1](#) to [3](#) are specific to each part and, therefore, are distinct from ISO 19085-1:2021, [Clauses 1](#) to [3](#).

For [Clauses 4](#) to [7](#) and the annexes, each subclause in ISO 19085-1:2021, is cited as:

- confirmed as a whole;
- confirmed with additions;
- excluded in total; or
- replaced with specific text.

ISO/FDIS 19085-6:2023(E)

This is indicated by one of the following possible statements:

- “ISO 19085-1:2021, [subclause/Annex], applies.”;
- “ISO 19085-1:2021, [subclause/Annex], applies with the following additions.” or “ISO 19085-1:2021, [subclause/Annex], applies with the following additions, subdivided into further specific subclauses.”;
- “ISO 19085-1:2021, [subclause/Annex], does not apply.”;
- “ISO 19085-1:2021, [subclause/Annex], is replaced by the following text.” or “ISO 19085-1:2021, [subclause/Annex], is replaced by the following text, subdivided into further specific subclauses.”.

Other subclauses and annexes specific to this document are indicated by the introductory sentence: “Subclause/Annex specific to this document.”.

iTeh Standards (<https://standards.iteh.ai>) Document Preview

[ISO/FDIS 19085-6](https://standards.iteh.ai/catalog/standards/sist/e30536dc-0137-4db7-86d4-37c86e94d7fc/iso-fdis-19085-6)

<https://standards.iteh.ai/catalog/standards/sist/e30536dc-0137-4db7-86d4-37c86e94d7fc/iso-fdis-19085-6>

Woodworking machines — Safety —

Part 6: Single spindle vertical moulding machines (toupie)

1 Scope

This document specifies the safety requirements and measures for single spindle vertical moulding machines (defined in [3.1](#)), capable of continuous production use and hereinafter referred to also as “machines”.

The machines are designed to cut solid wood and material with similar physical characteristics to wood.

It deals with all significant hazards, hazardous situations and events as listed in [Annex A](#), relevant to the machines when they are operated, adjusted and maintained as intended and under the conditions foreseen by the manufacturer including reasonably foreseeable misuse. Transport, assembly, dismantling, disabling and scrapping phases have also been taken into account.

It is also applicable to machines fitted with one or more of the following devices/additional working units, whose hazards have been dealt with:

- a) device to adjust the arbor vertically;
- b) device to tilt the arbor;
- c) device to fit a manually operated tenoning sliding table;
- d) glass bead saw unit;
- e) adjustable table insert;
- f) device for changing the direction of rotation of the spindle;
- g) device for fixing shank mounted tools on the arbor;
- h) interchangeable arbor;
- i) quick tool/arbor change system;
- j) demountable power feed unit;
- k) support for the demountable power feed unit with power-driven adjustments.

This document does not apply to

- 1) machines equipped with outboard bearings,
- 2) machines equipped with powered movements of a front extension table and/or a tenoning sliding table.

This document is not applicable to machines intended for use in potentially explosive atmospheres or to machines manufactured prior to the date of its publication.

2 Normative references

The following documents are referred to in the text in such a way that some or all of their content constitutes requirements of this document. For dated references, only the edition cited applies. For undated references, the latest edition of the referenced document (including any amendments) applies.

ISO 12100:2010, *Safety of machinery — General principles for design — Risk assessment and risk reduction*

ISO 13857:2019, *Safety of machinery — Safety distances to prevent hazard zones being reached by upper and lower limbs*

ISO 19085-1:2021, *Woodworking machines — Safety — Part 1: Common requirements*

EN 847-1:2017, *Tools for woodworking — Safety requirements — Part 1: Milling tools, circular saw blades*

EN 847-2:2017, *Tools for woodworking — Safety requirements — Part 2: Requirements for shanks of shank mounted milling tools*

EN 847-3:2013, *Tools for woodworking — Safety requirements — Part 3: Clamping devices*

3 Terms and definitions

For the purposes of this document, the terms and definitions given in ISO 12100:2010, and ISO 19085-1:2021 and the following apply.

ISO and IEC maintain terminology databases for use in standardization at the following addresses:

- ISO Online browsing platform: available at <https://www.iso.org/obp>
- IEC Electropedia: available at <https://www.electropedia.org/>

3.1

single spindle vertical moulding machine

hand-fed machine fitted with a single vertical arbor, which is fixed in position during the cutting operation and a horizontal table, which is fixed in total or in part during the cutting operation

Note 1 to entry: The arbor passes through the table and its drive is situated beneath the table.

Note 2 to entry: The main parts of the machine and their terminology are shown in [Figure 1](#).

Note 3 to entry: These machines are also known as shapers in the USA and toupie in Europe.

Note 4 to entry: The arbor can be tiltable and interchangeable or not interchangeable.

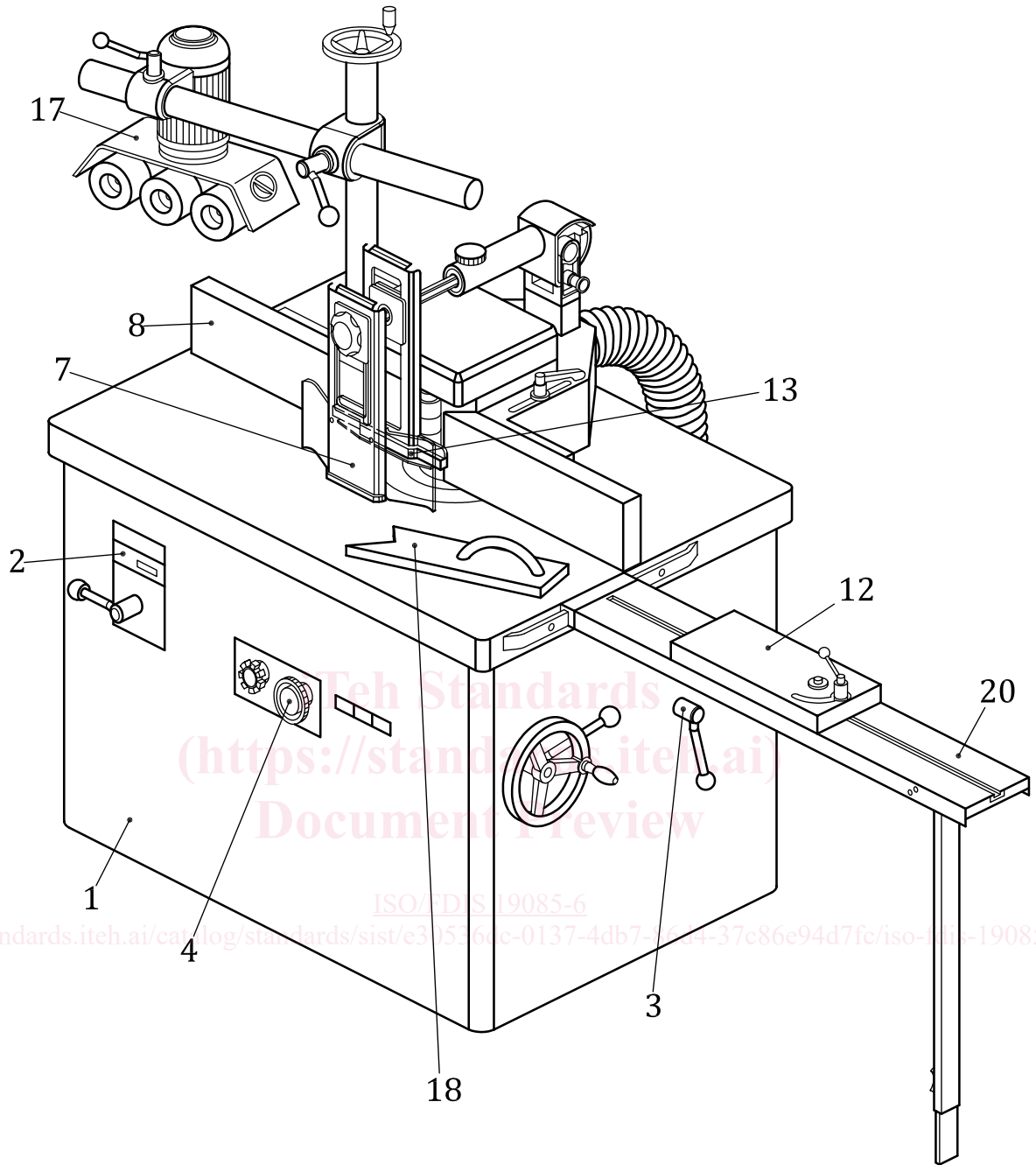

a) Example of a single spindle vertical moulding machine equipped for straight work

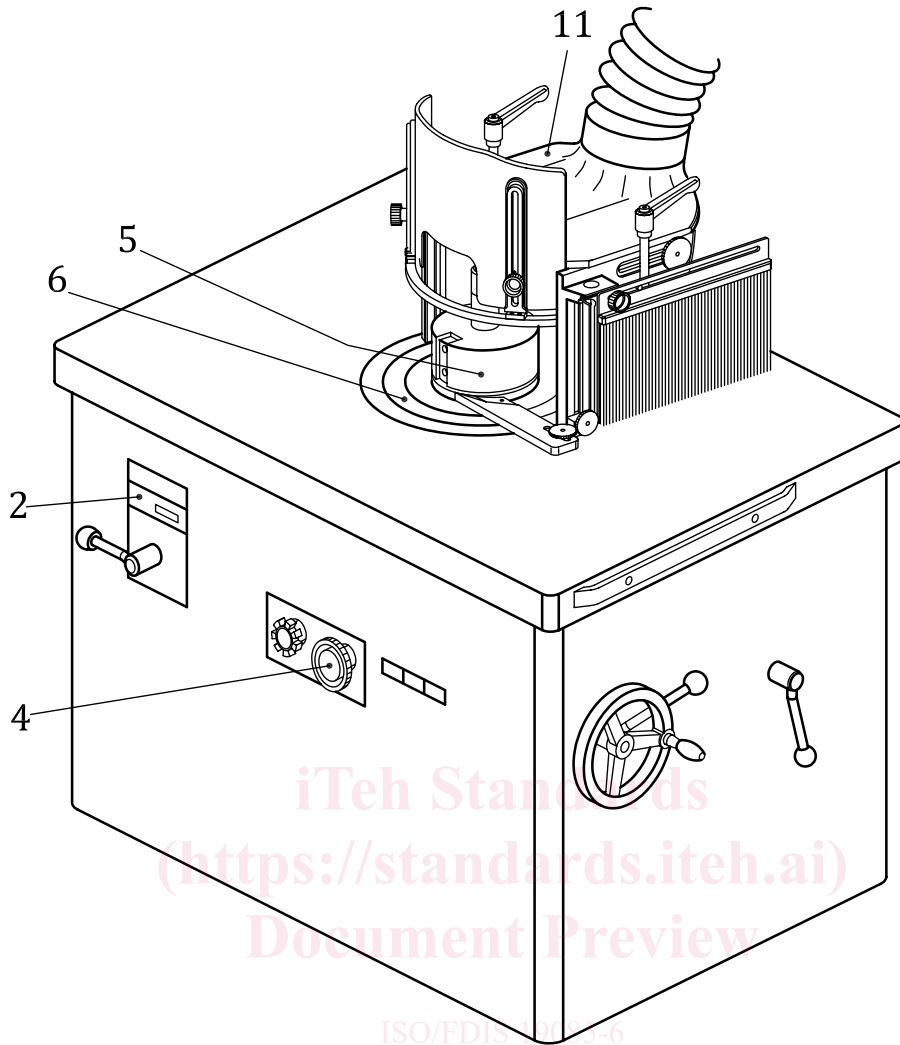

b) Example of a single spindle vertical moulding machine equipped for curved work

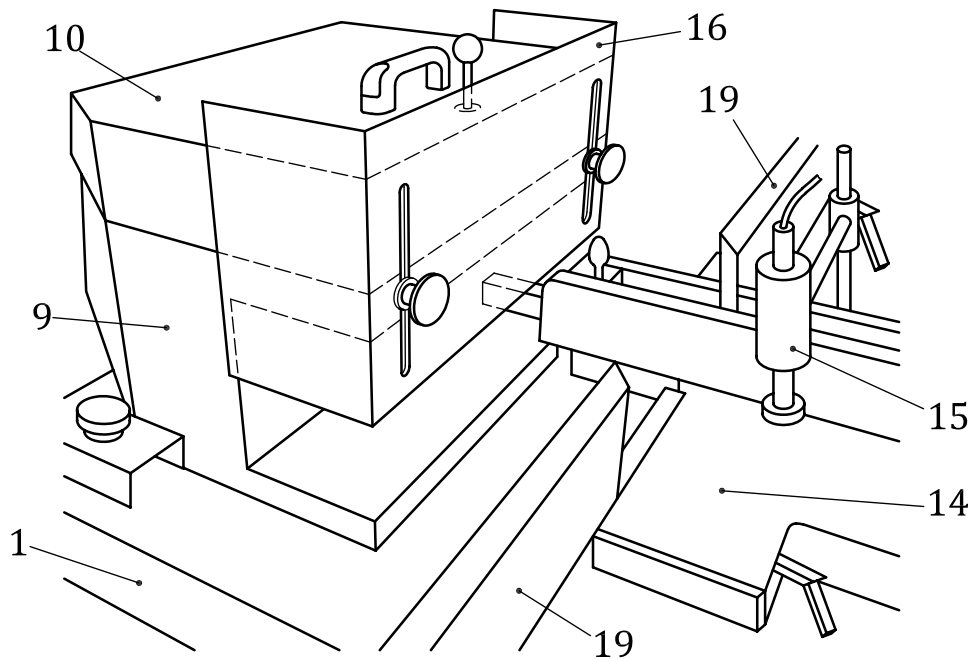

c) Example of a tool safeguard for tenoning with fixed and adjustable guards mounted on the machine and on the sliding table

Key

1	main frame	11	curved work guard
2	speed indicator	12	adjustable end stop
3	spindle lock	13	table pressure pad
4	start and stop controls	14	sliding table
5	tool	15	workpiece clamping device
6	table rings	16	adjustable guard
7	fence pressure pad	17	de-mountable power feed unit
8	fence plates connected to straight work guard	18	push stick
9	enclosure	19	guards fixed to the sliding table
10	hinged cover	20	extension table

Figure 1 — Single spindle vertical moulding machine terminology**3.2****straight work**

profiling or grooving of a workpiece with one face in contact with the table and a second with the fence, and where the work starts at one end of the workpiece and continues through to the other end

Note 1 to entry: See [Figures 1 a\)](#) and [2](#).

3.3**stopped straight work**

machining of only a part of the workpiece length

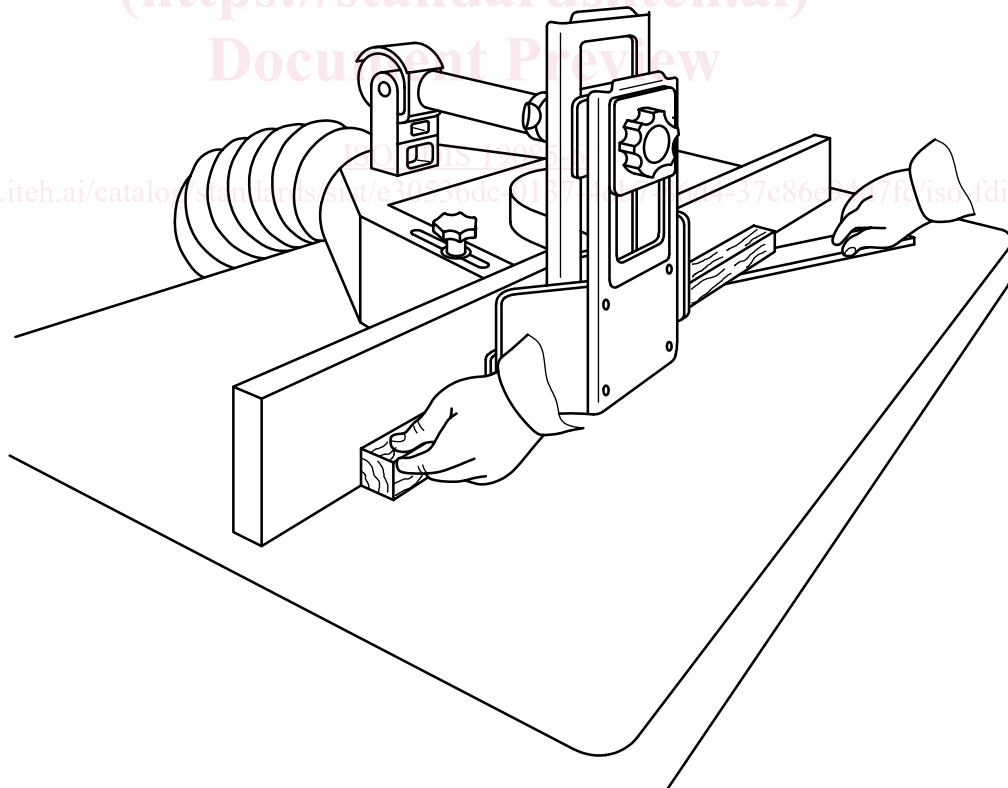
**Figure 2 — Example of straight work**

**3.4
curved work**

profiling or grooving of a curve on a workpiece by having one side in contact with the table (or if held in a jig with the jig in contact with the table) and the other in contact with the vertical reference of a steady or ball ring guide when using a jig

Note 1 to entry: See [Figures 1 b\)](#) and [3](#).

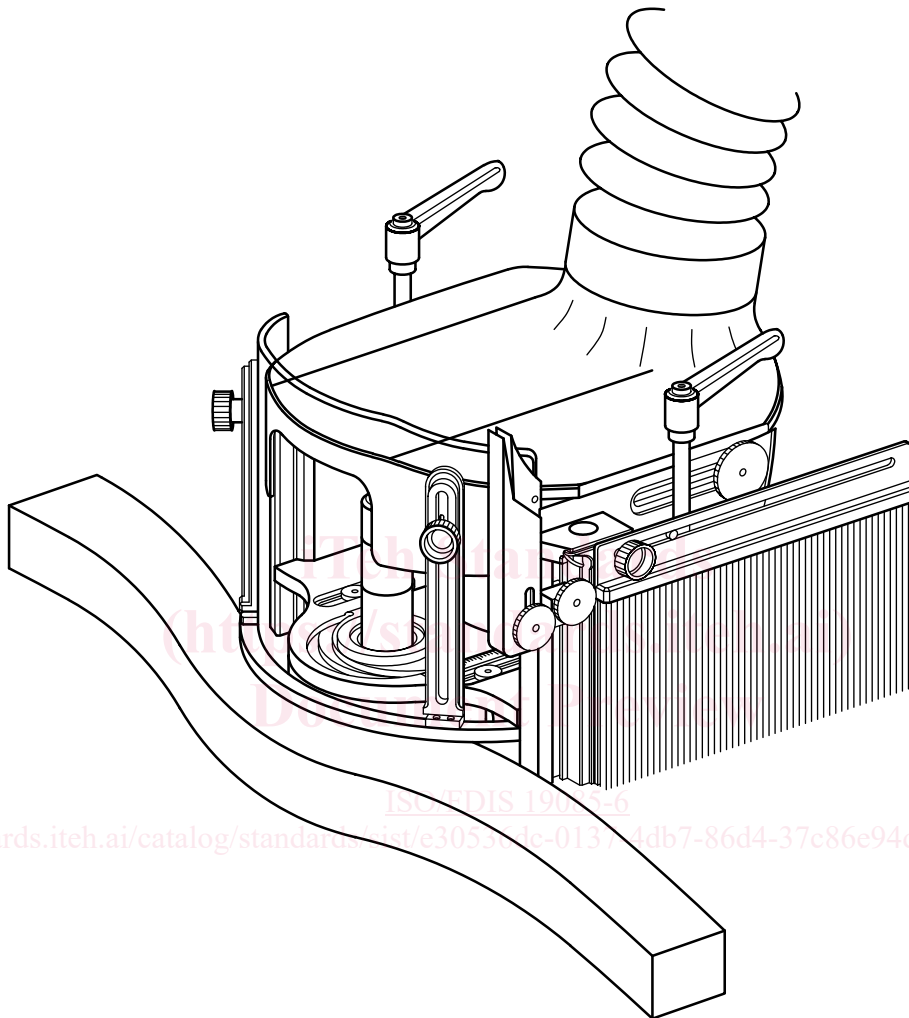

Figure 3 — Example of curved work

**3.5
tenoning**

machining of tenons and slots at the end of a workpiece to facilitate the joining of workpieces

Note 1 to entry: See [Figures 1 c\)](#), [4](#) and [5](#).