



Designation: **C143/C143M – 10a** C143/C143M – 12

Standard Test Method for Slump of Hydraulic-Cement Concrete¹

This standard is issued under the fixed designation C143/C143M; the number immediately following the designation indicates the year of original adoption or, in the case of revision, the year of last revision. A number in parentheses indicates the year of last reapproval. A superscript epsilon (ϵ) indicates an editorial change since the last revision or reapproval.

This standard has been approved for use by agencies of the Department of Defense.

1. Scope*

1.1 This test method covers determination of slump of hydraulic-cement concrete, both in the laboratory and in the field.

1.2 The values stated in either SI units or inch-pound units are to be regarded separately as standard. Within the text, the SI units are shown in brackets. The values stated in each system may not be exact equivalents; therefore, each system shall be used independently of the other. Combining values from the two systems may result in non-conformance with the standard.

1.3 The text of this standard references notes and footnotes which provide explanatory material. These notes and footnotes (excluding those in tables and figures) shall not be considered as requirements of the standard.

1.4 *This standard does not purport to address all of the safety concerns, if any, associated with its use. It is the responsibility of the user of this standard to establish appropriate safety and health practices and determine the applicability of regulatory limitations prior to use. (Warning—Fresh hydraulic cementitious mixtures are caustic and may cause chemical burns to skin and tissue upon prolonged exposure.²)*

2. Referenced Documents

2.1 *ASTM Standards:*³

[C31/C31M Practice for Making and Curing Concrete Test Specimens in the Field](#)

[C138/C138M Test Method for Density \(Unit Weight\), Yield, and Air Content \(Gravimetric\) of Concrete](#)

[C172 Practice for Sampling Freshly Mixed Concrete](#)

[C173/C173M Test Method for Air Content of Freshly Mixed Concrete by the Volumetric Method](#)

[C231 Test Method for Air Content of Freshly Mixed Concrete by the Pressure Method](#)

[C670 Practice for Preparing Precision and Bias Statements for Test Methods for Construction Materials](#)

[D638 Test Method for Tensile Properties of Plastics](#)

3. Summary of Test Method

3.1 A sample of freshly mixed concrete is placed and compacted by rodding in a mold shaped as the frustum of a cone. The mold is raised, and the concrete allowed to subside. The vertical distance between the original and displaced position of the center of the top surface of the concrete is measured and reported as the slump of the concrete.

4. Significance and Use

4.1 This test method is intended to provide the user with a procedure to determine slump of plastic hydraulic-cement concretes.

NOTE 1—This test method was originally developed to provide a technique to monitor the consistency of unhardened concrete. Under laboratory conditions, with strict control of all concrete materials, the slump is generally found to increase proportionally with the water content of a given concrete mixture, and thus to be inversely related to concrete strength. Under field conditions, however, such a strength relationship is not clearly and consistently shown. Care should therefore be taken in relating slump results obtained under field conditions to strength.

4.2 This test method is considered applicable to plastic concrete having coarse aggregate up to 1½ in. [37.5 mm] in size. If the coarse aggregate is larger than 1½ in. [37.5 mm] in size, the test method is applicable when it is performed on the fraction of

¹ This test method is under the jurisdiction of ASTM Committee C09 on Concrete and Concrete Aggregates and is the direct responsibility of Subcommittee C09.60 on Testing Fresh Concrete.

Current edition approved Oct. 1, 2010/Nov. 1, 2012. Published November 2010/November 2012. Originally approved in 1922. Last previous edition approved in 2010 as C143/C143M-10-10a. DOI: 10.1520/C0143-C0143M-10a.10.1520/C0143_C0143M-12

² Section on Safety Precautions, Manual of Aggregate and Concrete Testing, *Annual Book of ASTM Standards*, Vol. 04.02.

³ For referenced ASTM standards, visit the ASTM website, www.astm.org, or contact ASTM Customer Service at service@astm.org. For *Annual Book of ASTM Standards* volume information, refer to the standard's Document Summary page on the ASTM website.

*A Summary of Changes section appears at the end of this standard

concrete passing a 1½-in. [37.5-mm] sieve, with the larger aggregate being removed in accordance with the section titled “Additional Procedure for Large Maximum Size Aggregate Concrete” in Practice C172.

4.3 This test method is not considered applicable to non-plastic and non-cohesive concrete.

NOTE 2—Concretes having slumps less than ½ in. [15 mm] may not be adequately plastic and concretes having slumps greater than about 9 in. [230 mm] may not be adequately cohesive for this test to have significance. Caution should be exercised in interpreting such results.

5. Apparatus

5.1 *Mold*—The test specimen shall be formed in a mold made of metal or plastic not readily attacked by the cement paste. The metal mold shall not be thinner than 0.060 in. [1.5 mm] and if formed by the spinning process, there shall be no point on the mold at which the thickness is sufficiently rigid to maintain the specified dimensions and tolerances during use, resistant to impact forces, and shall be non-absorbent. Metal molds shall have an average thickness of not less than 0.060 in. [1.5 mm] with no individual thickness measurement less than 0.045 in. [1.15 mm]. Plastic molds shall be ABS plastic or equivalent (Note 3) with a minimum average wall thickness of 0.125 in. [3 mm], with no individual thickness measurement less than 0.100 in. [2.5 mm]. The manufacturer or supplier shall certify the materials used in mold construction are in compliance with the requirements of this test method. The mold shall be in the form of the lateral surface of the frustum of a cone with the base 8 in. [200 mm] in diameter, the top 4 in. [100 mm] in diameter, and the height 12 in. [300 mm]. Individual diameters and heights shall be within ± 1/8 in. [3 mm] of the prescribed dimensions. The base and the top shall be open and parallel to each other and at right angles to the axis of the cone. The mold shall be provided with foot pieces and handles similar to those shown in Fig. 1. The mold shall be constructed without a seam. The interior of the mold shall be relatively smooth and free from projections. The mold shall be free from dents, deformation, or adhered mortar. A mold which clamps to a nonabsorbent base plate is acceptable instead of the one illustrated, provided the clamping arrangement is such that it can be fully released without movement of the mold and the base is large enough to contain all of the slumped concrete in an acceptable test.

5.1.1 Check and record conformance to the mold’s specified dimensions when it is purchased or first placed in service and at least annually thereafter.

NOTE 3—ABS (Acrylonitrile Butadiene Styrene) plastic exhibits the following minimum mechanical properties:

Tensile modulus of elasticity,
at 73 °F [23 °C]

320 000 psi

[2206 MPa]

iTech Standards
(<https://standards.iteh.ai>)
Document Preview

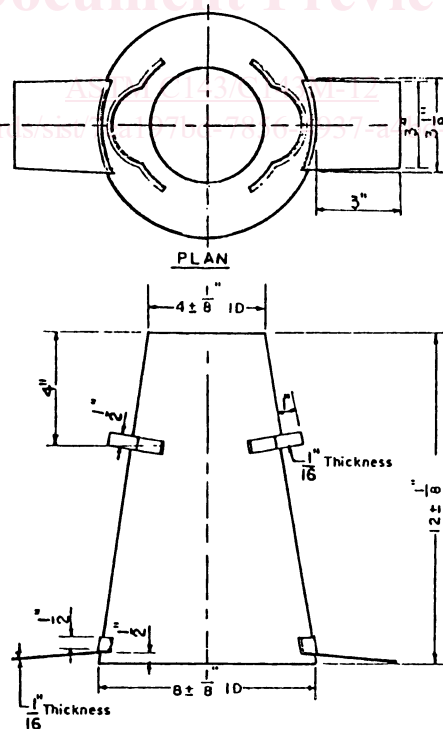

		Dimensional Units								
in.	1/16	1/8	1/2	1	3	3 1/8	4	8	12	
mm	[2]	[3]	[15]	[25]	[75]	[80]	[100]	[200]	[300]	

FIG. 1 Mold for Slump Test