

---

---

**Plastics — Thermoplastic materials  
— Determination of Vicat softening  
temperature (VST)**

*Plastiques — Matières thermoplastiques — Détermination de la  
température de ramollissement Vicat (VST)*

iTeh STANDARD PREVIEW  
(standards.iteh.ai)

ISO 306:2022

<https://standards.iteh.ai/catalog/standards/sist/522939a2-882d-4a85-9ac8-633e91ee3e61/iso-306-2022>



# iTeh STANDARD PREVIEW (standards.iteh.ai)

ISO 306:2022

<https://standards.iteh.ai/catalog/standards/sist/522939a2-882d-4a85-9ac8-633e91ee3e61/iso-306-2022>



## **COPYRIGHT PROTECTED DOCUMENT**

© ISO 2022

All rights reserved. Unless otherwise specified, or required in the context of its implementation, no part of this publication may be reproduced or utilized otherwise in any form or by any means, electronic or mechanical, including photocopying, or posting on the internet or an intranet, without prior written permission. Permission can be requested from either ISO at the address below or ISO's member body in the country of the requester.

ISO copyright office  
CP 401 • Ch. de Blandonnet 8  
CH-1214 Vernier, Geneva  
Phone: +41 22 749 01 11  
Email: [copyright@iso.org](mailto:copyright@iso.org)  
Website: [www.iso.org](http://www.iso.org)

Published in Switzerland

# Contents

Page

Foreword.....	iv
<b>1 Scope.....</b>	<b>1</b>
<b>2 Normative references.....</b>	<b>1</b>
<b>3 Terms and definitions.....</b>	<b>2</b>
<b>4 Principle.....</b>	<b>2</b>
<b>5 Apparatus.....</b>	<b>2</b>
5.1 Means of producing penetration.....	2
5.2 Indenter.....	3
5.3 Heating equipment.....	3
5.4 Weights.....	3
5.5 Temperature-measuring device.....	3
5.6 Penetration-measuring device.....	5
5.7 Micrometers and gauges.....	6
<b>6 Test specimens.....</b>	<b>6</b>
<b>7 Conditioning.....</b>	<b>6</b>
<b>8 Procedure.....</b>	<b>7</b>
<b>9 Precision.....</b>	<b>7</b>
<b>10 Test report.....</b>	<b>7</b>
<b>Annex A (informative) Comparison of VST results obtained with liquid-filled heating bath and direct-contact heating unit.....</b>	<b>9</b>
<b>Annex B (informative) Comparison of VST results obtained with liquid-filled heating bath and fluidized bed.....</b>	<b>11</b>
<b>Annex C (informative) Repeatability and precision.....</b>	<b>13</b>
<b>Bibliography.....</b>	<b>16</b>

## Foreword

ISO (the International Organization for Standardization) is a worldwide federation of national standards bodies (ISO member bodies). The work of preparing International Standards is normally carried out through ISO technical committees. Each member body interested in a subject for which a technical committee has been established has the right to be represented on that committee. International organizations, governmental and non-governmental, in liaison with ISO, also take part in the work. ISO collaborates closely with the International Electrotechnical Commission (IEC) on all matters of electrotechnical standardization.

The procedures used to develop this document and those intended for its further maintenance are described in the ISO/IEC Directives, Part 1. In particular, the different approval criteria needed for the different types of ISO documents should be noted. This document was drafted in accordance with the editorial rules of the ISO/IEC Directives, Part 2 (see [www.iso.org/directives](http://www.iso.org/directives)).

Attention is drawn to the possibility that some of the elements of this document may be the subject of patent rights. ISO shall not be held responsible for identifying any or all such patent rights. Details of any patent rights identified during the development of the document will be in the Introduction and/or on the ISO list of patent declarations received (see [www.iso.org/patents](http://www.iso.org/patents)).

Any trade name used in this document is information given for the convenience of users and does not constitute an endorsement.

For an explanation of the voluntary nature of standards, the meaning of ISO specific terms and expressions related to conformity assessment, as well as information about ISO's adherence to the World Trade Organization (WTO) principles in the Technical Barriers to Trade (TBT), see [www.iso.org/iso/foreword.html](http://www.iso.org/iso/foreword.html).

This document was prepared by Technical Committee TC 61, *Plastics*, Subcommittee SC 2, *Mechanical behavior*, in collaboration with the European Committee for Standardization (CEN) Technical Committee CEN/TC 249, *Plastics*, in accordance with the Agreement on technical cooperation between ISO and CEN (Vienna Agreement).

This sixth edition cancels and replaces the fifth edition (ISO 306:2013), which has been technically revised.

The main changes are as follows.

- The document has been updated to allow for the use of commercial universal equipment (i.e. covering both ISO 75 and ISO 306) and modern testing practices.

Any feedback or questions on this document should be directed to the user's national standards body. A complete listing of these bodies can be found at [www.iso.org/members.html](http://www.iso.org/members.html).

# Plastics — Thermoplastic materials — Determination of Vicat softening temperature (VST)

## 1 Scope

**1.1** This document specifies four methods for the determination of the Vicat softening temperature (VST) of thermoplastic materials:

- Method A50 using a force of 10 N and a heating rate of 50 °C/h;
- Method B50 using a force of 50 N and a heating rate of 50 °C/h;
- Method A120 using a force of 10 N and a heating rate of 120 °C/h;
- Method B120 using a force of 50 N and a heating rate of 120 °C/h.

**1.2** The methods specified are applicable only to thermoplastics, for which they give a measure of the temperature at which the thermoplastics start to soften rapidly.

## 2 Normative references

The following documents are referred to in the text in such a way that some or all of their content constitutes requirements of this document. For dated references, only the edition cited applies. For undated references, the latest edition of the referenced document (including any amendments) applies.

ISO 291, *Plastics — Standard atmospheres for conditioning and testing*

ISO 293, *Plastics — Compression moulding of test specimens of thermoplastic materials*

ISO 294-1, *Plastics — Injection moulding of test specimens of thermoplastic materials — Part 1: General principles, and moulding of multipurpose and bar test specimens*

ISO 294-2, *Plastics — Injection moulding of test specimens of thermoplastic materials — Part 2: Small tensile bars*

ISO 294-3, *Plastics — Injection moulding of test specimens of thermoplastic materials — Part 3: Small plates*

ISO 472, *Plastics — Vocabulary*

ISO 2818, *Plastics — Preparation of test specimens by machining*

ISO 16012, *Plastics — Determination of linear dimensions of test specimens*

ISO 20753, *Plastics — Test specimens*

IEC 60584-1, *Thermocouples — Part 1: EMF specifications and tolerances*

IEC 60584-3, *Thermocouples — Part 3: Extension and compensating cables — Tolerances and identification system*

IEC 60751, *Industrial platinum resistance thermometers and platinum temperature sensors*

### 3 Terms and definitions

For the purposes of this document, the terms and definitions given in ISO 472 and the following apply.

ISO and IEC maintain terminology databases for use in standardization at the following addresses:

- ISO Online browsing platform: available at <https://www.iso.org/obp>
- IEC Electropedia: available at <https://www.electropedia.org/>

#### 3.1 penetration

distance over which the indenting tip has to penetrate into the specimen under test

Note 1 to entry: It is expressed in millimetres (mm).

#### 3.2 load

force applied to test specimen by means of the indenting tip

Note 1 to entry: It is expressed in Newtons (N).

#### 3.3 Vicat softening temperature VST

temperature at which a flat-ended indenter will penetrate the specimen to a depth of 1 mm under a specified *load* (3.2) using a selected uniform rate of temperature rise

Note 1 to entry: It is expressed in degrees Celsius (°C).

### 4 Principle

The temperature at which a standard indenting tip with a flat point, under a standardized load, penetrates 1 mm into the surface of a plastic test specimen is determined. The indenting tip exerts a specified force perpendicular to the test specimen, while the specimen is heated at a specified and uniform rate.

The temperature, in degree Celsius (°C), of the specimen, measured as close as possible to the indented area at 1 mm penetration, is quoted as the VST.

### 5 Apparatus

#### 5.1 Means of producing penetration

The apparatus shall be constructed essentially as shown in [Figure 1](#) (or [Figure 2](#)). It consists of a rigid metal frame in which a rod moves freely in the vertical direction. One end of the rod is fitted with a weight-carrying plate and the other end is equipped with an indenting tip. The base of the frame is fitted with a support plate or other suitable load-application device.

It is recommended that the rod and frame(s) be constructed of low thermal expansion material. Unless vertical parts of the apparatus have the same coefficient of linear thermal expansion, the difference in change of length of these parts during the test introduces an error in the reading of the apparent penetration of the test specimen.

At the time of manufacture, or after repair or replacement of test frame, a blank test shall be made on each apparatus using a test specimen made of rigid material having a low coefficient of expansion and a thickness comparable to that of the specimen under test. The blank test shall cover the temperature ranges to be used in the actual determination, and a correction term shall be determined for each temperature. If the correction term is 0,02 mm or greater, its value and algebraic sign shall be recorded;

and the term applied to each test result by adding it algebraically to the reading of the apparent penetration of the test specimen.

NOTE Invar and borosilicate glass have been found suitable as materials for the test specimen in the blank test.

## 5.2 Indenter

It shall be made of hardened steel, at least 2 mm long, of circular cross-section and of area  $(1,000 \pm 0,015)$  mm<sup>2</sup> (corresponding to an indenting tip diameter of  $(1,128 \pm 0,008)$  mm) and fixed at the bottom of the rod. The indenter, when in contact with the specimen, shall be perpendicular to the rod. The tip shall be free from burrs or other imperfections.

## 5.3 Heating equipment

The heating equipment shall be a heating bath containing a suitable liquid, a fluidized bed, or a direct contact heating unit, see [Figure 2](#). For heat transfer media other than gas (air) the test specimen shall be immersed to a depth of at least 35 mm.

An efficient stirrer or means to fluidize the solid heat transfer medium shall be provided. If liquids are used for heat transfer, it shall be established that the liquid chosen is stable over the temperature range used and does not affect the material under test, for example causing it to swell or crack.

The method using a liquid heat transfer medium shall be considered a reference method in case of doubts or conflicts, if possible, in the temperature range under consideration.

The heating equipment shall be provided with a control unit so that the temperature is raised at a uniform rate of  $(50 \pm 5)$  °C/h or  $(120 \pm 10)$  °C/h.

The heating rate shall be verified periodically either by checking the automatic temperature reading, or manually checking the temperature. The requirement for the heating rate shall be considered satisfied if, over every 6 min interval during the test, the temperature change is  $(5,0 \pm 0,5)$  °C or  $(12,0 \pm 1,0)$  °C.

It is allowable for the first 10 min or up to 40 °C of the ramp to be outside of the prescribed tolerances as many instruments use a PID control for the heating, and it is normal for the controller to tune itself to the correct power and interval requirements to perform the required ramp rate.

NOTE A means of accelerating the cooling rate of the heating equipment has been found to be desirable.

Liquid paraffin, transformer oil, glycerol and silicone oils are suitable heat transfer liquids, but others are acceptable. For fluidized beds, aluminium oxide powder has been found suitable.

## 5.4 Weights

A set of weights shall be provided so that the total load applied to the test specimen is  $(10 \pm 0,2)$  N for methods A50 and A120 or  $(50 \pm 1,0)$  N for methods B50 and B120.

## 5.5 Temperature-measuring device

Use a suitable temperature-measuring device of appropriate range and with a resolution of 0,1 °C (or readable to 0,1 °C) and an accuracy of  $\pm 1$  °C. The temperature-measuring devices shall be calibrated at the depth of immersion particular to the apparatus in use and in a temperature range that comprises the Vicat softening temperatures to be measured. It is recommended that the heating bath is equipped with a separate temperature-measuring device at each test station if there are several. In this case, the temperature-sensing part of the instrument shall be located not farther than 12,5 mm from the point

where the indenting tip contacts the specimen. The temperature sensing part of the instrument shall not touch the specimen or be in contact with any part of the frame.

NOTE Methods of calibration of the temperature-measuring devices include static calibration (at one or more constant temperatures) and dynamic calibration (using a constant heating-rate). Dynamic calibration is capable of measuring temperature lag of the build-in temperature measuring device but requires a reference temperature measuring device with suitable dynamic properties.

Thermocouples shall be in accordance with the requirements of IEC 60584-1 and IEC 60584-3. Resistance thermometers shall be in accordance with the requirements of IEC 60751.

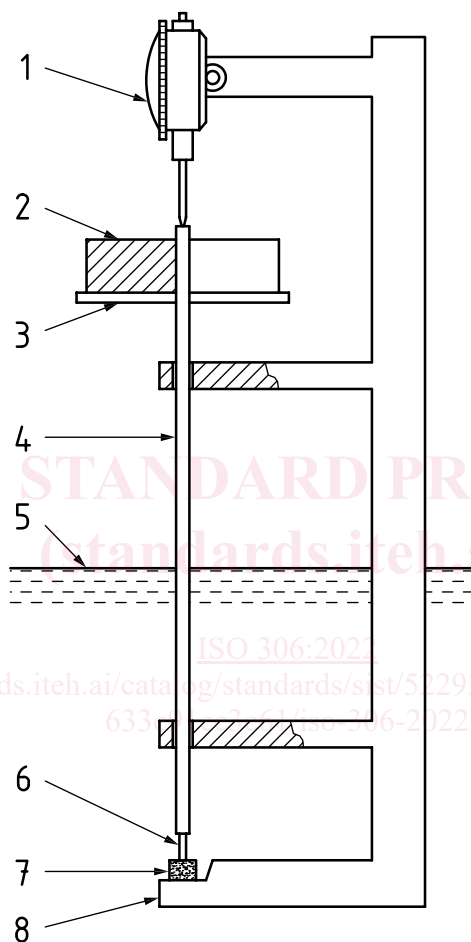

**Key**

- |                                |   |
|--------------------------------|---|
| 1 penetration-measuring device | 5 approximate level of liquid or fluidized powder bed |
| 2 replaceable weight           | 6 indenting tip                                       |
| 3 support plate                | 7 test specimen                                       |
| 4 rod with indenting tip       | 8 test-specimen support/frame                         |

**Figure 1 — Schematic view of one type of testing apparatus with a heating equipment filled with liquid or fluidized powder bed for determination of the VST**

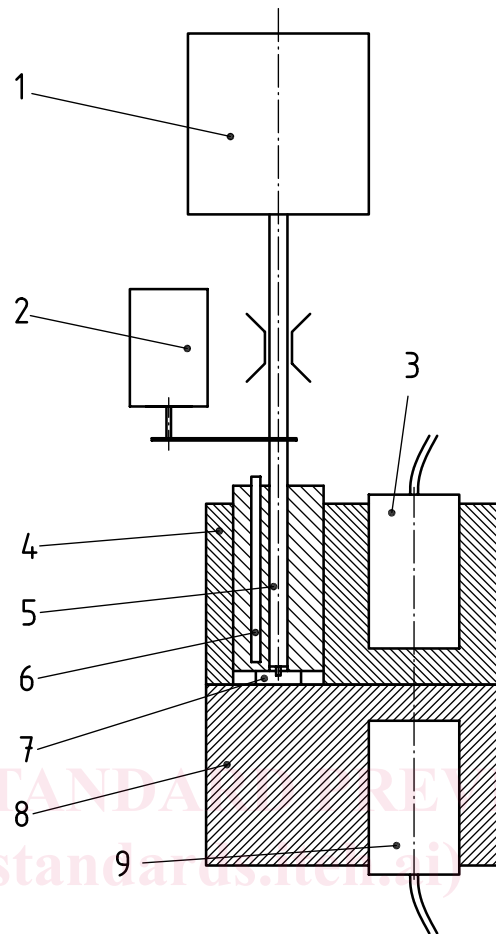

**Key**

1	weight	6	temperature-measuring device
2	penetration-measuring device	7	test specimen
3	upper heater	8	lower heating block
4	upper heating block	9	lower heater
5	rod with indenting tip		

**Figure 2 — Schematic view of testing apparatus with a direct-contact heating unit for determination of the VST**

### 5.6 Penetration-measuring device

Use a calibrated dial gauge, or any other indicating or recording device, including electrical displacement sensing apparatus, such as a linear variable displacement transducer (LVDT), to measure the penetration of the specimen at the point where the indenting tip contacts the specimen. The penetration-measuring device shall be readable to 0,01 mm.

When analogue dial gauges are used, the thrust of the dial gauge, which contributes to the thrust on the test specimen, shall be recorded. The force of the dial gauge spring is directed upwards and is subtracted from the load; in other types, this force acts downwards and is added to the load. Since the force exerted by the spring in certain dial gauges varies considerably over the stroke, this force is measured at the position where the indenting tip has penetrated 1 mm into the specimen. The combined downward thrust, determined during calibration of the apparatus, due to the rod, the indenting tip and the upward or downward force exerted by the dial gauge spring in the measurement range used during the test, shall not exceed 1 N.

## 5.7 Micrometers and gauges

These are used to measure the width and thickness of the test specimens. They shall be readable to 0,01 mm and conform to ISO 16012.

## 6 Test specimens

**6.1** At least two test specimens shall be used to test each sample. The test specimens shall be between 3 mm and 6,5 mm thick and at least 9,5 mm square or of 9,5 mm diameter. Their surfaces shall be flat and parallel and free from flash. They shall be made in accordance with the specifications, if any, for the material under test. In the absence of such specifications, any suitable procedure used for the preparation of test specimens shall be agreed upon by the interested parties.

**6.2** If the samples submitted for test are in the form of moulding materials (for example, powder or granulated materials), these shall be moulded into specimens 3 mm to 6,5 mm thick, in accordance with the specifications relating to the material under test, or in accordance with ISO 293, ISO 294-1, ISO 294-2, ISO 294-3, or ISO 20753 if no material specification exists. If these are not applicable, other procedures shall be used as agreed between the interested parties.

**6.3** For sheet materials, the thickness of the test specimens shall be equal to the thickness of the sheet, except as follows.

- a) If the thickness exceeds 6,5 mm, the test specimens shall be reduced in thickness to 3 mm to 6,5 mm by machining one surface (in accordance with ISO 2818), the other surface being left intact. The test surface shall be the intact one.
- b) If the thickness of the sheet is less than 3 mm, not more than three pieces shall be stacked together in direct contact to give a total thickness between 3 mm and 6,5 mm and the thickness of the upper (measured) piece shall be at least 1,5 mm. Stacking of pieces of lesser thickness does not always give the same test result.

If test specimens are taken from formed parts, ensure that the specimens:

- are taken from a relatively flat and preferably non-grained area of the part to be tested;
- are in planar contact to each other when several pieces are stacked;
- are positioned in such a way that the grained surface of the sample is (or the grained surfaces of all the pieces are) facing away from the indentation tip.

**6.4** The test results obtained may depend on the moulding conditions used in the preparation of the test specimens, although such a dependence is not common. When testing materials for which the results do depend on the moulding conditions, special annealing or preconditioning procedures may be used before testing provided they are agreed to by the interested parties.

## 7 Conditioning

Condition for at least 16 h at the normal climate 23/50-2 according to ISO 291 or in accordance with the appropriate material specification.

If the VST of the material under investigation is not affected by moisture, controlling of the moisture shall be omitted.

## 8 Procedure

**8.1** If using a liquid-filled heating bath or a fluidized bed, mount the test specimen horizontally under the indenting tip of the unloaded rod, perpendicular to the indenting tip. If using a Direct-contact heating unit, place the test specimen horizontally and perpendicular to the direction of travel of the indenting tip, without placing the indenting tip on the specimen. The indenting tip shall at no point be nearer than 3 mm to the edge of the test specimen. The surface of the test specimen in contact with the base of the apparatus shall be flat.

**8.2** If using a liquid-filled heating bath or a fluidized bed (see [Figure 1](#)), place the rod/frame assembly in the heating equipment. If using a direct-contact heating unit, position the specimen between the two blocks and lower the indenting tip on to the specimen (see [Figure 2](#)). The temperature of the heating equipment shall be a maximum of 25 °C at the start of each test, unless previous tests have shown that, for the material under test, no error is caused by starting at another temperature and the starting temperature is at least 50 °C below the expected VST.

**8.3** With the indenter still in position, add a sufficient weight to the support plate (or load the indenter in another suitable way), so that the total thrust on the test specimen will be  $(10 \pm 0,2)$  N for methods A50 and A120 and  $(50 \pm 1,0)$  N for methods B50 and B120. After 5 min with the load applied, note the reading of the indentation-measuring device) (see [5.5](#)) or set the instrument to zero.

**8.4** Increase the temperature at a uniform rate of  $(50 \pm 5)$  °C/h or  $(120 \pm 10)$  °C/h as appropriate for the test method selected. When a liquid-filled heating bath or a fluidized bed is used, stir the heating medium well during the test. For reference tests, a rate of 50 °C/h shall be used.

NOTE For some materials tested at the higher heating rate (120 °C/h), Vicat softening temperatures have been observed which are up to 10 °C higher than those obtained when testing at 50 °C/h.

**8.5** Record the temperature of the heating medium or the heating block (see [5.4](#)) when the indenter has penetrated into the test specimen by  $(1 \pm 0,01)$  mm from its starting position, as defined in [8.3](#), and record it as the VST of the test specimen. [ee3e61/iso-306-2022](#)

**8.6** Express the VST of the material under test as the arithmetic mean of the VSTs of the specimens tested. If the range of the individual results is greater than 2 °C, record the individual results [see [Clause 10](#), list item h)] and repeat the test a second time using an additional set of at least two specimens. In the event of repeat testing, report the individual values from both the first and second tests. Report the VST with one decimal. Express the test result(s) to the nearest decimal Celsius.

## 9 Precision

See [Annex C](#). For comparison of results, see [Annexes A](#) and [B](#).

## 10 Test report

The test report shall include the following information:

- a) a reference to this document, i.e. ISO 306:2022;
- b) full identification of the material tested;
- c) the method employed (A50, A120, B50 or B120);
- d) the thickness and the number of layers of composite test specimens (i.e. specimens consisting of more than one layer) if these are used;
- e) the method of preparation of the test specimens used;