

FINAL
DRAFT

INTERNATIONAL
STANDARD

ISO/FDIS
5735-1

ISO/TC 269/SC 1

Secretariat: AFNOR

Voting begins on:
2023-12-13

Voting terminates on:
2024-02-07

Railway infrastructure — Non-destructive testing on rails in track —
Part 1:
Requirements for ultrasonic testing and evaluation principles

iTeh Standards
(<https://standards.iteh.ai>)
Document Preview

[ISO/FDIS 5735-1](#)

<https://standards.iteh.ai/catalog/standards/sist/5b91618d-f191-48f5-9039-b5c994208b22/iso-fdis-5735-1>

RECIPIENTS OF THIS DRAFT ARE INVITED TO SUBMIT, WITH THEIR COMMENTS, NOTIFICATION OF ANY RELEVANT PATENT RIGHTS OF WHICH THEY ARE AWARE AND TO PROVIDE SUPPORTING DOCUMENTATION.

IN ADDITION TO THEIR EVALUATION AS BEING ACCEPTABLE FOR INDUSTRIAL, TECHNOLOGICAL, COMMERCIAL AND USER PURPOSES, DRAFT INTERNATIONAL STANDARDS MAY ON OCCASION HAVE TO BE CONSIDERED IN THE LIGHT OF THEIR POTENTIAL TO BECOME STANDARDS TO WHICH REFERENCE MAY BE MADE IN NATIONAL REGULATIONS.



Reference number
ISO/FDIS 5735-1:2023(E)

© ISO 2023

iTeh Standards
(<https://standards.iteh.ai>)
Document Preview

[ISO/FDIS 5735-1](https://standards.iteh.ai/catalog/standards/sist/5b91618d-f191-48f5-9039-b5c994208b22/iso-fdis-5735-1)

<https://standards.iteh.ai/catalog/standards/sist/5b91618d-f191-48f5-9039-b5c994208b22/iso-fdis-5735-1>



COPYRIGHT PROTECTED DOCUMENT

© ISO 2023

All rights reserved. Unless otherwise specified, or required in the context of its implementation, no part of this publication may be reproduced or utilized otherwise in any form or by any means, electronic or mechanical, including photocopying, or posting on the internet or an intranet, without prior written permission. Permission can be requested from either ISO at the address below or ISO's member body in the country of the requester.

ISO copyright office
CP 401 • Ch. de Blandonnet 8
CH-1214 Vernier, Geneva
Phone: +41 22 749 01 11
Email: copyright@iso.org
Website: www.iso.org

Published in Switzerland

Contents

	Page
Foreword.....	iv
Introduction.....	v
1 Scope.....	1
2 Normative references.....	1
3 Terms and definitions.....	1
4 General.....	3
5 Principle of ultrasonic testing in track.....	3
6 Ultrasonic testing speed and detection of discontinuities.....	3
7 Simulation of internal reflectors in reference rails.....	4
Annex A (normative) Reflectors for reference rails in Europe.....	5
Annex B (normative) Reflectors for reference rails in China.....	29
Annex C (normative) Reflectors for reference rails in Japan.....	39
Annex D (informative) Ultrasonic test areas in rails tested with test vehicles or manually propelled devices.....	49
Bibliography.....	55

iTech Standards
(<https://standards.iteh.ai>)
Document Preview

[ISO/FDIS 5735-1](https://standards.iteh.ai/catalog/standards/sist/5b91618d-f191-48f5-9039-b5c994208b22/iso-fdis-5735-1)

<https://standards.iteh.ai/catalog/standards/sist/5b91618d-f191-48f5-9039-b5c994208b22/iso-fdis-5735-1>

Foreword

ISO (the International Organization for Standardization) is a worldwide federation of national standards bodies (ISO member bodies). The work of preparing International Standards is normally carried out through ISO technical committees. Each member body interested in a subject for which a technical committee has been established has the right to be represented on that committee. International organizations, governmental and non-governmental, in liaison with ISO, also take part in the work. ISO collaborates closely with the International Electrotechnical Commission (IEC) on all matters of electrotechnical standardization.

The procedures used to develop this document and those intended for its further maintenance are described in the ISO/IEC Directives, Part 1. In particular, the different approval criteria needed for the different types of ISO document should be noted. This document was drafted in accordance with the editorial rules of the ISO/IEC Directives, Part 2 (see www.iso.org/directives).

ISO draws attention to the possibility that the implementation of this document may involve the use of (a) patent(s). ISO takes no position concerning the evidence, validity or applicability of any claimed patent rights in respect thereof. As of the date of publication of this document, ISO had not received notice of (a) patent(s) which may be required to implement this document. However, implementers are cautioned that this may not represent the latest information, which may be obtained from the patent database available at www.iso.org/patents. ISO shall not be held responsible for identifying any or all such patent rights.

Any trade name used in this document is information given for the convenience of users and does not constitute an endorsement.

For an explanation of the voluntary nature of standards, the meaning of ISO specific terms and expressions related to conformity assessment, as well as information about ISO's adherence to the World Trade Organization (WTO) principles in the Technical Barriers to Trade (TBT), see www.iso.org/iso/foreword.html.

This document was prepared by Technical Committee ISO/TC 269, *Railway applications*, Subcommittee SC 1, *Infrastructure*.

A list of all parts in the ISO 5735 series can be found on the ISO website.

Any feedback or questions on this document should be directed to the user's national standards body. A complete listing of these bodies can be found at www.iso.org/members.html.

Introduction

This document represents the actual state of the art of continuous ultrasonic testing of rails in track applied by railway companies.

Timely detection of discontinuities (irregularities) in the rails installed in track is very important to ensure the strength and stability of the rails in track. Discontinuities (irregularities) pose a threat to the strength and integrity of the rails and should be identified in order to ensure safer transportation.

Welded joints are included but do not get a specific focus.

iTeh Standards
(<https://standards.iteh.ai>)
Document Preview

[ISO/FDIS 5735-1](https://standards.iteh.ai/catalog/standards/sist/5b91618d-f191-48f5-9039-b5c994208b22/iso-fdis-5735-1)

<https://standards.iteh.ai/catalog/standards/sist/5b91618d-f191-48f5-9039-b5c994208b22/iso-fdis-5735-1>

Railway infrastructure — Non-destructive testing on rails in track —

Part 1: Requirements for ultrasonic testing and evaluation principles

1 Scope

This document specifies the requirements for testing principles and systems to produce comparable results with regard to location, type and size of discontinuities in rails. This document does not aim to give any guidelines for managing the result of ultrasonic rail testing. This document only applies to flat bottom (Vignole) railway rail profile 43 kg/m and above.

This document only applies to continuous testing of rails installed in track for detecting internal discontinuities.

This document only applies to testing equipment fitted to dedicated test vehicles or manually propelled devices. This document treats welded joints as plain rail.

This document does not define the requirements for vehicle acceptance. This document does not apply to ultrasonic testing of rails in a production plant.

2 Normative references

The following documents are referred to in the text in such a way that some or all of their content constitutes requirements of this document. For dated references, only the edition cited applies. For undated references, the latest edition of the referenced document (including any amendments) applies.

ISO 5577:2017, *Non-destructive testing — Ultrasonic testing — Vocabulary*

3 Terms and definitions

For the purposes of this document, the terms and definitions given in ISO 5577 and the following apply.

ISO and IEC maintain terminology databases for use in standardization at the following addresses:

- ISO Online browsing platform: available at <https://www.iso.org/obp>
- IEC Electropedia: available at <https://www.electropedia.org/>

3.1

structure of the rail

components that constitute the rail as shown in [Figure 1](#)

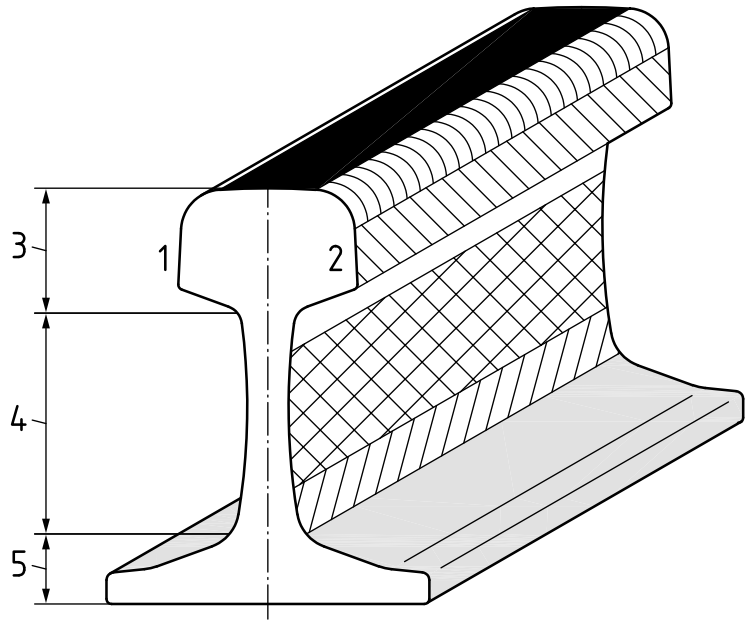

Key

- 1 field side
- 2 gauge side
- 3 rail head
- 4 rail web
- 5 rail foot



running surface



gauge corner area



rail head side area



rail head fillet radius area



rail web area



rail foot fillet radius area



rail foot area

iTeh Standards
(<https://standards.itih.ai>)
Document Preview

[ISO/FDIS 5735-1](https://standards.itih.ai/catalog/standards/sist/5b91618d-f191-48f5-9039-b5c994208b22/iso-fdis-5735-1)

<https://standards.itih.ai/catalog/standards/sist/5b91618d-f191-48f5-9039-b5c994208b22/iso-fdis-5735-1>

Figure 1 — Structure of the rail

3.2

reference reflector

artificial feature designed to represent a discontinuity of a known size, orientation and position for continuous testing of an ultrasonic system

3.3

indication

signal shown on the display of an ultrasonic instrument or system as a result of received ultrasonic pulse

[SOURCE: ISO 5577:2017, 6.5.14, modified — "which can be separated from noise, surface and back-wall echoes" has been replaced with "or system as a result of received ultrasonic pulse" in the definition.]

4 General

In order to verify the performance of the continuous ultrasonic systems for rail testing, there shall be defined reference reflectors in a test track. These reference reflectors shall be recorded and reported at the normal operational speed of the test vehicle/system.

The reference rails in the test track shall be constructed from new rail to provide the correct head profile and running surface condition. Rails with corrosion on the running surface shall be cleaned to allow the transmission of sound prior to any testing, for example using a powered steel wire brush.

Evidence of an indication is obtained by non-destructive testing.

In this document, a test system uses sound at a frequency range of 2 MHz to 5 MHz.

A flat-bottomed hole (FBH) shall be machined using a twist drill at the appropriate diameter followed by a slot drill hole of the same diameter to the required depth to generate the flat end of the hole. Accuracy in diameter and depth shall be within 0,1 mm. Accuracy in angle shall be within 0,1°.

A side-drilled hole (SDH) shall be machined using a twist drill at the appropriate diameter. Accuracy in diameter shall be within 0,1 mm. Accuracy in angle shall be within 0,1°.

An electrical discharge machined (EDM) notch shall be machined to the desired shape and orientation with an accuracy of 0,1 mm. Accuracy in angle shall be within 0,1°. As an alternative for the manufacturing of reflectors in longer sections of rail, water jet cutting can be used instead of EDM.

Due to wear of the rail, dimension can vary. If the rail is used for distance and sensitivity setting of ultrasonic testing (UT) inspection devices, this needs to be taken into account.

A verification of the ultrasonic testing inspection devices shall be carried out to the specification and intervals required by the infrastructure manager.

5 Principle of ultrasonic testing in track

Ultrasonic waves transmitted into the structure of the rail, see [Figure 1](#), are reflected from the surfaces of the rail body. Fractures and other discontinuities within the rail, as well as the boundary of the rail act as reflecting surfaces. By receiving, recording and interpreting the returned ultrasonic signals, it is possible to detect discontinuities within a rail installed in track before they present an unacceptable risk to the integrity and strength of the rail. [Annex D](#) gives examples of test areas in rails tested with test vehicles or manually propelled devices.

6 Ultrasonic testing speed and detection of discontinuities

Ultrasonic beams have a width which is determined by the size of the transducer and the frequency. All reflectors interact with the ultrasonic beam. The beam sweeps across the reflector when either the vehicle or the manually propelled device, or both, travels along the track. The sound wave is being reflected and detected by the transducer. All ultrasonic systems use a gate threshold level and the system records a response when the reflection is above the gate threshold level. By controlling the gain in the ultrasonic system and the gate threshold level the number of responses for a given size of reflector can be defined.

When evaluating an A-scan, a signal to noise ratio of at least 3 is required.

The B-scan display of a reflector should not contain unwanted representation of spurious and multiple echoes.

A reflector can be sized by setting the system parameters so that a known number of responses are received from a known sized reference reflector. The relationship of the number of responses and the size of the reference reflector is known. This applies to all the reflectors given in [Annex A](#), [Annex B](#) and [Annex C](#).

The maximum testing speed depends upon the rail profile (longitudinal and transverse), reflector size to be detected, the beam width, sampling frequency and the number of responses required for an indication to be recorded.

The non-direct tested zone depends on the sensitivity of used ultrasonic system and testing speed.

7 Simulation of internal reflectors in reference rails

Reference rails incorporating sets of reference reflectors selected from the given tables of reflectors shall be created. They shall be installed in the left and right rails of a section of track if test vehicles are used. If only trolleys or manually propelled devices are used, the reference rails may be installed out-of-track. The length of the reference rails is not defined by this document. Reference reflectors shall be orientated to check probes scanning in both directions.

To prevent the influence of water and dirt on the ultrasonic responses, reference holes and notches shall be plugged with a synthetic compound.

Where the reference rails carry traffic, the infrastructure manager shall carry out a risk assessment to determine if reinforcement of the reference reflectors is necessary (fishplates or similar) and determine the maintenance regime of the reference rails.

When several values are given for a certain quantity, all tables in [Annex A](#), [Annex B](#) and [Annex C](#) shall be consulted. If a range is given for a quantity, the user may choose a value within this range.

For example, reflector No. 01, see [Table A.1](#), consists of two holes in a rail. All holes have a diameter of 6 mm. The distance from the running surface to the centre of the hole is 12 mm for the first hole and 20 mm for the second hole respectively. Choosing to install reflector No. 01 leads to two holes in the reference rail.

Reflector No. 02, see [Table A.1](#), consists of four holes in a rail, two holes for the forward direction and two holes for the backward direction. The distance from the running surface (see [Figure A.2](#)) can be chosen within a range of 10 mm to 20 mm. The holes per direction have a diameter of 5 mm and 10 mm respectively. Choosing to install reflector No. 02 leads to at least four holes in the reference rail.

<https://standards.iteh.ai/catalog/standards/sist/5b91618d-f191-48f5-9039-b5c994208b22/iso-fdis-5735-1>

Annex A (normative)

Reflectors for reference rails in Europe

A.1 Dimensions of reflectors in reference rails

Reference rails shall be created with the reflectors and dimensions of [Table A.1](#).

Table A.1 — Description of reference reflectors and their dimensions

No.	Figure	Description	Dimensions mm
01	Figure A.1	Volumetric reflector in rail head	$a = 12; 20$ $d = 6$
02	Figure A.2	Central transverse reflector (20°) in rail head	$a = 10$ to 20 $d = 5; 10$
03	Figure A.3	Gauge transverse reflector (20°) in rail head	$a = 10$ to 20 $b = 10$ to 15 $d = 5; 10$
04	Figure A.4	Full width transverse reflector (20°) in rail head	$a = 20$ $d = 3$ $l = 7$
05	Figure A.5	Full width transverse reflector (35°) in rail head	$a = 20$ $d = 3$ $l = 7$
06	Figure A.6	Full width transverse reflector (53°) in rail head	$a = 20$ $d = 3$ $l = 7$
07	Figure A.7	Volumetric reflector gauge side of rail head	$a = 25$ $b = 20; 25; 30; 36$ $d = 6$ to 8
08	Figure A.8	Volumetric reflector field side of rail head	$a = 25$ $b = 20; 25; 30; 36$ $d = 6$ to 8
09	Figure A.9	Horizontal reflector in rail head	$a = 20$ $d = 8; 10$
10	Figure A.10	Horizontal bolt hole slot	$l = 5; 10$
11	Figure A.11	Bolt hole slot, position A	$l = 5; 10$
12	Figure A.12	Bolt hole slot, position B	$l = 5; 10$
13	Figure A.13	Bolt hole slot, position C	$l = 5; 10$
14	Figure A.14	Bolt hole slot, position D	$l = 5; 10$
15	Figure A.15	Volumetric reflector at head – web radius	$d = 6$
16	Figure A.16	Volumetric reflector at mid – web	$d = 6$
17	Figure A.17	Volumetric reflector at foot – web radius	$d = 6$
18	Figure A.18	Head – web radius transverse reflector (35°)	$d = 3$ $l = 10$

For symbols, see relevant figures in [Clause A.3](#).

Table A.1 (continued)

No.	Figure	Description	Dimensions mm
19	Figure A.19	Foot – web radius transverse reflector (53°)	$d = 3$ $l = 10$
20	Figure A.20	Vertical longitudinal reflector (version 1)	$a = 20$ $h = 10; 15; 20$ $l = 50 \text{ to } 100$
21	Figure A.21	Vertical longitudinal reflector (version 2)	$a = 20$ $d = 5$ $l = 50 \text{ to } 100$
22	Figure A.22	Change in foot depth	$c_1 = 5$ $c_2 = 10$ $l = 80$ $w = 30$
23	Figure A.23	Rail foot notch 5 mm	$c = 5$ $r = 17$
24	Figure A.24	Rail foot notch 10 mm	$c = 10$ $r = 22$
25	Figure A.25	Multiple repeated reflector	$a = 25$ $d = 6$ 10 holes within 2 000
26	Figure A.26	Resolution check reflector	$a = 25$ $d = 6$ $l_1 = 8$ $l_2 = 9$ $l_3 = 11$ $l_4 = 13$ $l_5 = 16$ $l_6 = 21$ $l_7 = 26$

For symbols, see relevant figures in [Clause A.3](#).

A.2 Detection of reference reflectors

The reference reflectors listed in [Table A.1](#) shall be detectable with the probe angles listed in [Table A.2](#).

Where the end of a drill hole is used as a reflector the hole bottom shall be machined flat (FBH – flat bottomed hole).

The ultrasonic probe angles listed in [Table A.2](#) are used in most ultrasonic test vehicles or manually propelled devices. The infrastructure manager shall define which probe angles are to be used. The infrastructure manager shall decide for which reflector a loss of rail foot reflection should be represented. This depends on what reflectors are to be detected.

All angled probes shall be configured to scan in both directions (forward and backward). Reference reflectors shall be orientated to check probe scanning in both directions.

Table A.2 — Reference reflectors to be detected with defined probe angles

No.	Reflector	Centreline of the rail head					Parallel within the gauge side or field side	Squinting in the direction of gauge side or field side
		0°	35° to 40°	50° to 60°	Transverse 45° to 55°	65° to 70°	65° to 70°	65° to 70°
01	Volumetric reflector in rail head	X	X	X		X	X	X
02	Central transverse reflector (20°) in rail head					X		
03	Gauge transverse reflector (20°) in rail head						X	
04	Full width transverse reflector (20°) in rail head					X	X	
05	Full width transverse reflector (35°) in rail head			X		X	X	
06	Full width transverse reflector (53°) in rail head		X					
07	Volumetric reflector gauge side of rail head						X	X
08	Volumetric reflector field side of rail head						X	X
09	Horizontal reflector in rail head	X						
10	Horizontal bolt hole slot	X						
11	Bolt hole slot, position A		X					
12	Bolt hole slot, position B		X					
13	Bolt hole slot, position C		X					
14	Bolt hole slot, position D		X					
15	Volumetric reflector at head – web radius	X	X	X				
16	Volumetric reflector at mid – web	X	X					
17	Volumetric reflector at foot – web radius	X	X					
18	Head – web radius transverse reflector (35°)			X				
19	Foot – web radius transverse reflector (53°)		X					
20	Vertical longitudinal reflector (version 1)				X			
21	Vertical longitudinal reflector (version 2)	X			X			
22	Change in foot depth	X						
23	Rail foot notch 5 mm		X					
24	Rail foot notch 10 mm		X					
25	Multiple repeated reflector	X	X	X		X	X	X
26	Resolution check reflector	X	X	X		X	X	

A.3 Figures of reference reflectors

This clause specifies figures of reference reflectors.

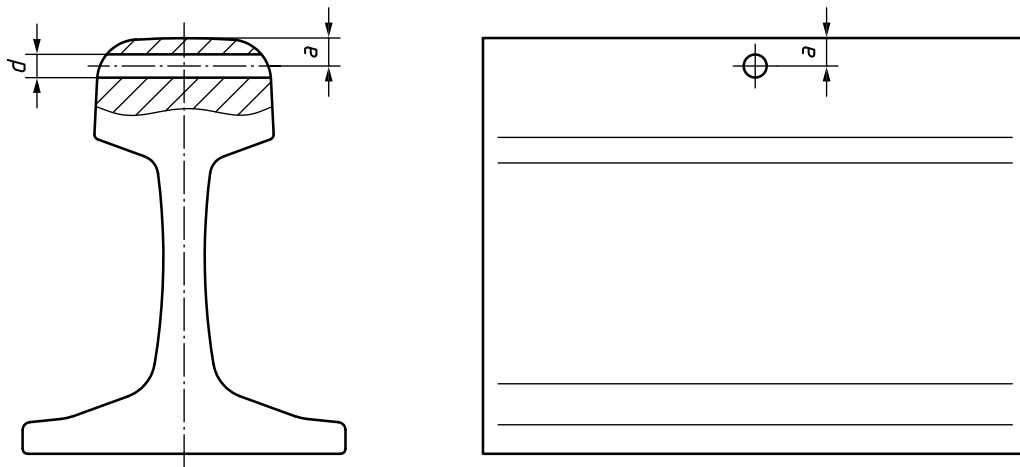

Key

- a* see [Table A.1](#)
- d* see [Table A.1](#)

Figure A.1 — Volumetric reflector in rail head

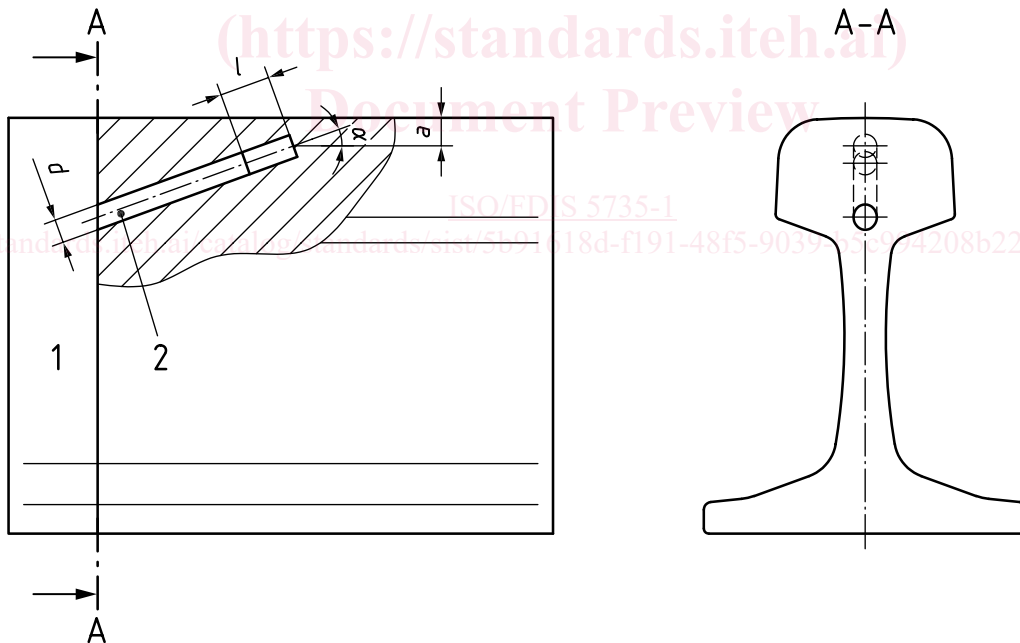

Key

- | | | | |
|----------|-------------------------------|----------|--------------------|
| <i>a</i> | see Table A.1 | <i>l</i> | 20 mm |
| <i>d</i> | see Table A.1 | <i>1</i> | weld |
| <i>α</i> | 20° | <i>2</i> | plug of rail steel |

Figure A.2 — Central transverse reflector (20°) in rail head