**Textile glass — Staple fibres or
filaments — Determination of average
diameter**

*Verre textile — Fibres discontinues et filaments — Détermination du
diamètre moyen*

iTeh STANDARD PREVIEW
(standards.iteh.ai)

ISO 1888:2022

<https://standards.iteh.ai/catalog/standards/sist/62fa98e3-9d0a-48ed-b1a8-de624a8fe5f2/iso-1888-2022>



iTeh STANDARD PREVIEW
(standards.iteh.ai)

ISO 1888:2022

<https://standards.iteh.ai/catalog/standards/sist/62fa98e3-9d0a-48ed-b1a8-de624a8fe5f2/iso-1888-2022>



COPYRIGHT PROTECTED DOCUMENT

© ISO 2022

All rights reserved. Unless otherwise specified, or required in the context of its implementation, no part of this publication may be reproduced or utilized otherwise in any form or by any means, electronic or mechanical, including photocopying, or posting on the internet or an intranet, without prior written permission. Permission can be requested from either ISO at the address below or ISO's member body in the country of the requester.

ISO copyright office
CP 401 • Ch. de Blandonnet 8
CH-1214 Vernier, Geneva
Phone: +41 22 749 01 11
Email: copyright@iso.org
Website: www.iso.org

Published in Switzerland

Contents

	Page
Foreword.....	iv
1 Scope	1
2 Normative references	1
3 Terms and definitions	1
4 Method A: Longitudinal profile	1
4.1 Principle.....	1
4.2 Apparatus.....	1
4.3 Procedure.....	2
5 Method B: Transverse section	3
5.1 Principle.....	3
5.2 Apparatus.....	3
5.3 Procedure.....	4
6 Method C: Determination of the diameter by calculation	5
6.1 Principle.....	5
6.2 Test specimen.....	5
6.3 Procedure.....	6
7 Expression of results	6
8 Test report	6

(standards.iteh.ai)

[ISO 1888:2022](https://standards.iteh.ai/catalog/standards/sist/62fa98e3-9d0a-48ed-b1a8-de624a8fe5f2/iso-1888-2022)

<https://standards.iteh.ai/catalog/standards/sist/62fa98e3-9d0a-48ed-b1a8-de624a8fe5f2/iso-1888-2022>

Foreword

ISO (the International Organization for Standardization) is a worldwide federation of national standards bodies (ISO member bodies). The work of preparing International Standards is normally carried out through ISO technical committees. Each member body interested in a subject for which a technical committee has been established has the right to be represented on that committee. International organizations, governmental and non-governmental, in liaison with ISO, also take part in the work. ISO collaborates closely with the International Electrotechnical Commission (IEC) on all matters of electrotechnical standardization.

The procedures used to develop this document and those intended for its further maintenance are described in the ISO/IEC Directives, Part 1. In particular, the different approval criteria needed for the different types of ISO documents should be noted. This document was drafted in accordance with the editorial rules of the ISO/IEC Directives, Part 2 (see www.iso.org/directives).

Attention is drawn to the possibility that some of the elements of this document may be the subject of patent rights. ISO shall not be held responsible for identifying any or all such patent rights. Details of any patent rights identified during the development of the document will be in the Introduction and/or on the ISO list of patent declarations received (see www.iso.org/patents).

Any trade name used in this document is information given for the convenience of users and does not constitute an endorsement.

For an explanation of the voluntary nature of standards, the meaning of ISO specific terms and expressions related to conformity assessment, as well as information about ISO's adherence to the World Trade Organization (WTO) principles in the Technical Barriers to Trade (TBT), see www.iso.org/iso/foreword.html.

This document was prepared by Technical Committee ISO/TC 61, *Plastics*, Subcommittee SC 13, *Composites and reinforcement fibres*.

This fourth edition cancels and replaces the third edition (ISO 1888:2006), which has been technically revised.

The main changes are as follows:

- “Method C” (determination of the diameter by calculation) has been added.

Any feedback or questions on this document should be directed to the user's national standards body. A complete listing of these bodies can be found at www.iso.org/members.html.

Textile glass — Staple fibres or filaments — Determination of average diameter

1 Scope

This document specifies three test methods used for determining the average diameter (i.e. the average value of actual diameters) of staple fibres or filaments in a textile glass product.

2 Normative references

The following documents are referred to in the text in such a way that some or all of their content constitutes requirements of this document. For dated references, only the edition cited applies. For undated references, the latest edition of the referenced document (including any amendments) applies.

ISO 472, *Plastics — Vocabulary*

ISO 1889, *Reinforcement yarns — Determination of linear density*

ISO 12154, *Determination of density by volumetric displacement — Skeleton density by gas pycnometry*

3 Terms and definitions

For the purposes of this document, the terms and definitions given in ISO 472 apply.

ISO and IEC maintain terminology databases for use in standardization at the following addresses:

- ISO Online browsing platform: available at <https://www.iso.org/obp>
- IEC Electropedia: available at <https://www.electropedia.org/>

4 Method A: Longitudinal profile

4.1 Principle

Fibres or filaments placed in a liquid medium having a refractive index differing from that of the textile glass are viewed in profile under a microscope and the diameter measured.

4.2 Apparatus

4.2.1 Microscope, equipped with the following:

- An eye-piece with a built-in micrometer graticule, the eye-piece and objective together giving an overall magnification of at least $\times 400$ and preferably $\times 1\,000$. The resolution of the microscope shall permit measurement to the nearest $0,5\ \mu\text{m}$ or better.
- A system permitting lateral and rotational movement of the microscope stage.
- An illumination system.

This system may be replaced by or used in conjunction with a microprojector on which specimens can be measured using a transparent scale (preferably a curved scale).

The recommended type of microscope is one using plane-polarized light, and an illumination system with a Kohler light source and an Abbe condenser. A green filter may also be used to give better reading accuracy.

4.2.2 Micrometer scale, with 0,01 mm divisions, for calibration of the optical system.

4.2.3 Glass slide (thickness: 1,10 mm to 1,35 mm), and cover glass (thickness: 0,16 mm to 0,19 mm). The thickness of the cover glass shall be verified periodically.

4.2.4 Mounting fluid, with a refractive index different (but not too different) from that of the glass under examination. Benzyl alcohol, methyl salicylate, a mixture of one part glycerol and two parts water are adequate media.

4.2.5 Razor blade or scissors.

4.2.6 Muffle furnace, capable of maintaining a temperature of $625\text{ °C} \pm 25\text{ °C}$.

4.3 Procedure

4.3.1 It is not always necessary to remove the size from the yarns under examination. Nevertheless, yarns in which the fibres or filaments do not separate from each other in the mounting fluid shall have the size removed by burning off to bare glass at 625 °C in a muffle furnace (4.2.6).

4.3.2 Set up the microscope (4.2.1) with the appropriate optical system and the moving stage. Calibrate the optical system using the micrometer scale (4.2.2).

4.3.3 Prepare the specimen and the specimen holder as follows:

- Using a sharp cutting device (4.2.5), prepare a specimen of fibres or filaments not exceeding 25 mm in length.
- Place the specimen on the glass slide (4.2.3).
- Separate the fibres or filaments so that they are no longer in a compact bundle, but still essentially parallel to each other.
- Using a glass rod, place one drop of mounting fluid (4.2.4) on the slide so that it wets the specimen and cover with a cover glass (4.2.3).

4.3.4 Place the slide on the microscope stage and, after adjusting the position of the specimen to obtain a clear, sharp view of the edges of the fibres or filaments, position the slide so that the micrometer graticule in the eyepiece is perpendicular to one of the fibres or filaments.

4.3.5 Move the micrometer graticule from one edge of the fibre or filament to the other edge and note the distance moved.

When using a microprojector (see 4.2.1), simply measure the distance from edge to edge of the fibre or filament on the transparent scale.

4.3.6 Move the slide around to obtain 25 readings on randomly selected fibres or filaments.

4.3.7 Calculate the arithmetic mean of the 25 measurements and convert this value to micrometres, using the magnification coefficient of the optical system.

5 Method B: Transverse section

5.1 Principle

A transverse section of a yarn that has been impregnated with resin and cured is viewed under a microscope and the diameter of a given number of fibres or filaments in the yarn is measured.

5.2 Apparatus

5.2.1 Microscope, equipped with the following:

- An eye-piece with a built-in micrometer graticule, the eye-piece and objective together giving an overall magnification of at least $\times 400$ and preferably $\times 1\,000$. The resolution of the microscope shall permit measurement to the nearest $0,5\ \mu\text{m}$ or better.
- A system permitting lateral and rotational movement of the microscope stage.
- An illumination system.

This system may be replaced by or used in conjunction with a microprojector on which specimens can be measured using a transparent scale (preferably a curved scale).

The recommended type of microscope is one using plane-polarized light, and an illumination system with a Kohler light source and an Abbe condenser. A green filter may also be used to give better reading accuracy.

5.2.2 Micrometer scale, with $0,01\ \text{mm}$ divisions, for calibration of the optical system.

5.2.3 Impregnation system, with fast-curing polyester or epoxide resin.

5.2.4 Moulding assembly (see [Figure 1](#) for an example).

5.2.5 Saw, suitable for cutting specimens.

5.2.6 Polishing device.

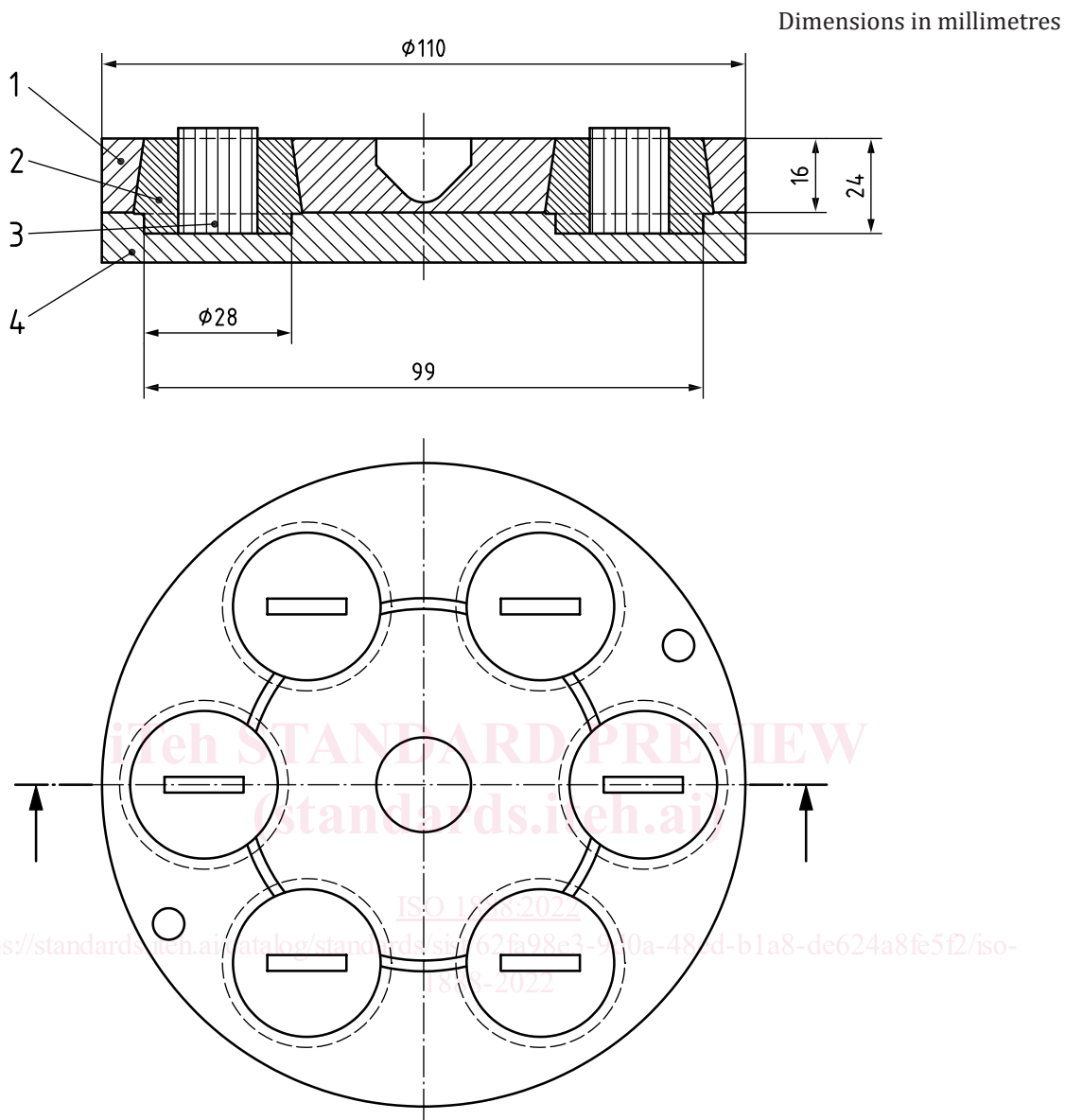

Key

- 1 sample holder (metal)
- 2 resin
- 3 yarn/small plate
- 4 mould (rubber or silicone elastomer)

Figure 1 — Example of assembly for moulding specimens

5.3 Procedure

5.3.1 Preliminary operations

Set up the microscope (5.2.1) with the appropriate optical system and the moving stage. Calibrate the optical system using the micrometer scale (5.2.2).

5.3.2 Preparation of the specimen

Bond a length of the yarn whose fibres or filaments are to be examined to a small plate of suitable material by means of a small amount of resin (5.2.3). Allow the resin to harden.

Place the plate plus yarn into the mould of the moulding device (see 5.2.4) so that it stands vertically. Fill the mould with the prepared resin and allow to cure.

Polish the upper surface of the moulding with the polishing device (5.2.6) until a perfectly flat, smooth surface is obtained. The recommended abrasive for finishing is finer than F1000.

Remove the moulding and, using the saw (5.2.5), cut a thin disc (about 4 mm thick) from the top of the moulding. This constitutes the specimen to be examined under the microscope.

5.3.3 Location and centring of the specimen

To facilitate the location of the specimen in the field of view, reduce the magnification to a value such as, for example, $\times 150$. When the specimen has been located, return to the higher magnification and complete centring.

The ends of the glass fibres and filaments will appear as bright discs.

Adjust the illumination to reduce the area of diffused light around each of these discs to a minimum, keeping the light bright enough for the scale to be read easily.

Bring the discs under the micrometer graticule.

5.3.4 Measurements

Move the microscope stage so that one of the graduations of the micrometer graticule is tangential to a disc. Record the number of divisions, estimating to the nearest half-division, corresponding to the diameter of the disc.

Oval-shaped discs may be observed. These are obliquely cut sections due to the fact that not all the fibres or filaments in the specimen are perpendicular to the polished surface. These oval discs can be used to determine the diameter provided that the smallest dimension is measured, this being the only one that represents the diameter of the filament.

Make diameter measurements on 25 discs taken at random over the specimen. To do this, move the microscope stage across the field of view so that, for each measurement, one of the graduations of the micrometer graticule is tangential to a disc.

If it proves impossible to make 25 measurements in this way, begin again along another axis, avoiding second measurements on the same fibres, until 25 measurements have been obtained.

5.3.5 Calculate the arithmetic mean of the 25 measurements and convert this value to micrometres, using the magnification coefficient of the optical system.

6 Method C: Determination of the diameter by calculation

6.1 Principle

The average diameter of fibres or filaments of a yarn is calculated from the linear density of the yarn, the density of the material of fibres or filaments and the number of fibres or filaments in the yarn, provided these data are available.

6.2 Test specimen

Yarns are used as test specimens, the amount of yarn taken shall be as specified in ISO 1889.

6.3 Procedure

An average filament diameter is determined from the linear density of the unsized yarn determined in accordance with ISO 1889, the density determined in accordance with ISO 12154 and the number of filaments in the yarn. The number of filaments in the yarn shall be given by the glass fibre manufacturer.

Calculate the average filament diameter d , expressed in μm , using [Formula \(1\)](#):

$$d = \sqrt{\frac{4t \times 10^3}{\pi \cdot \rho \cdot c}} \quad (1)$$

where

- t is the linear density of the yarn, in tex;
- ρ is the density of the yarn, in grams per cubic centimetre;
- c is the number of filaments in the yarn.

7 Expression of results

Express the result to the nearest 0,5 μm .

8 Test report

The test report shall contain the following information:

- a) a reference to this document (i.e. ISO 1888:2022) and the method used (A or B or C);
- b) all the details necessary for identification of the yarn examined;
- c) a statement to the effect that desizing was carried out, if applicable;
- d) the magnification used;
- e) the average diameter as a test result, including standard deviation where appropriate;
- f) details of any operation not described in this document, as well as any incident liable to have affected the results;
- g) the date of the test.