**Ice makers for commercial use —
Classification, requirements and test
conditions**

*Machines à glaçons à usage commercial — Classification, exigences et
conditions d'essai*

iTeh STANDARD PREVIEW
(standards.iteh.ai)

ISO 6369:2023

<https://standards.iteh.ai/catalog/standards/sist/6168dbda-ec55-4cf8-b5c7-05a33db329aa/iso-6369-2023>



iTeh STANDARD PREVIEW (standards.iteh.ai)

ISO 6369:2023

<https://standards.iteh.ai/catalog/standards/sist/6168dbda-ec55-4cf8-b5c7-05a33db329aa/iso-6369-2023>



COPYRIGHT PROTECTED DOCUMENT

© ISO 2023

All rights reserved. Unless otherwise specified, or required in the context of its implementation, no part of this publication may be reproduced or utilized otherwise in any form or by any means, electronic or mechanical, including photocopying, or posting on the internet or an intranet, without prior written permission. Permission can be requested from either ISO at the address below or ISO's member body in the country of the requester.

ISO copyright office
CP 401 • Ch. de Blandonnet 8
CH-1214 Vernier, Geneva
Phone: +41 22 749 01 11
Email: copyright@iso.org
Website: www.iso.org

Published in Switzerland

Contents

Page

Foreword.....	iv
1 Scope.....	1
2 Normative references.....	1
3 Terms and definitions.....	1
3.1 Types of appliances.....	1
3.2 Type of condenser cooling.....	2
3.3 Type of ice.....	2
3.4 Type of production.....	2
4 Measurement of energy consumption, water consumption and ice production capacity.....	3
4.1 General.....	3
4.2 Test room.....	3
4.3 Ambient temperature.....	4
4.4 Water supply.....	4
4.5 Location of unit in test room.....	5
4.6 Power supply.....	5
4.7 Set-up and operation of the ice maker.....	5
4.7.1 Ice maker set-up.....	5
4.7.2 Ice maker operation.....	5
4.8 Accuracy of measurement and instrumentation.....	5
4.9 Test procedure.....	6
4.9.1 Simultaneous tests.....	6
4.9.2 Stabilization.....	6
4.9.3 Ice sampling.....	6
4.10 Recording.....	6
4.10.1 General.....	6
4.10.2 Ice production capacity test.....	7
4.10.3 Water consumption test.....	7
4.10.4 Energy consumption test.....	7
4.11 Calculations.....	7
4.11.1 Ice production capacity.....	7
4.11.2 Cooling water used in condenser.....	7
4.11.3 Potable water used in ice-making.....	7
4.11.4 Energy consumption.....	8
5 Ice quality measurement by method of calorimetry.....	8
5.1 Instrumentation.....	8
5.2 Procedure for calorimeter constant determination.....	8
5.3 Procedure for determining net cooling effect of harvested ice.....	9
6 Information to be declared.....	11

Foreword

ISO (the International Organization for Standardization) is a worldwide federation of national standards bodies (ISO member bodies). The work of preparing International Standards is normally carried out through ISO technical committees. Each member body interested in a subject for which a technical committee has been established has the right to be represented on that committee. International organizations, governmental and non-governmental, in liaison with ISO, also take part in the work. ISO collaborates closely with the International Electrotechnical Commission (IEC) on all matters of electrotechnical standardization.

The procedures used to develop this document and those intended for its further maintenance are described in the ISO/IEC Directives, Part 1. In particular, the different approval criteria needed for the different types of ISO documents should be noted. This document was drafted in accordance with the editorial rules of the ISO/IEC Directives, Part 2 (see www.iso.org/directives).

Attention is drawn to the possibility that some of the elements of this document may be the subject of patent rights. ISO shall not be held responsible for identifying any or all such patent rights. Details of any patent rights identified during the development of the document will be in the Introduction and/or on the ISO list of patent declarations received (see www.iso.org/patents).

Any trade name used in this document is information given for the convenience of users and does not constitute an endorsement.

For an explanation of the voluntary nature of standards, the meaning of ISO specific terms and expressions related to conformity assessment, as well as information about ISO's adherence to the World Trade Organization (WTO) principles in the Technical Barriers to Trade (TBT), see www.iso.org/iso/foreword.html.

This document was prepared by Technical Committee ISO/TC 86, *Refrigeration and air-conditioning*, Subcommittee SC 7, *Testing and rating of commercial refrigerated display cabinets*, in collaboration with the European Committee for Standardization (CEN) Technical Committee CEN/TC 44, *Commercial and professional refrigerating appliances and systems, performance and energy consumption*, in accordance with the Agreement on technical cooperation between ISO and CEN (Vienna Agreement).

Any feedback or questions on this document should be directed to the user's national standards body. A complete listing of these bodies can be found at www.iso.org/members.html.

Ice makers for commercial use — Classification, requirements and test conditions

1 Scope

This document specifies methods for the measurement of energy consumption, water consumption, ice production capacity and the harvested ice characteristics of ice makers with built-in condensing units for commercial use.

This document does not apply to:

- ice makers intended to be incorporated in appliances for household use;
- ice makers with remote condensing units.

2 Normative references

There are no normative references in this document.

3 Terms and definitions

For the purposes of this document, the following terms and definitions apply.

ISO and IEC maintain terminology databases for use in standardization at the following addresses:

- ISO Online browsing platform: available at <https://www.iso.org/obp>
- IEC Electropedia: available at <https://www.electropedia.org/>

3.1 Types of appliances

3.1.1

ice maker

factory-made appliance consisting of a condensing unit and ice-making section operating as an integrated unit, with means for making and harvesting ice, also including means for storing or dispensing ice, or both

Note 1 to entry: Ice makers are intended to produce ice in irregular shapes or flakes or ribbons or wafers as well as uniformly shaped ice cubes.

Note 2 to entry: A modular-type ice maker is an ice maker without storage means.

Note 3 to entry: A self-contained ice maker is an ice-maker in which the ice-making mechanism, storage compartment and condensing unit are integrated within a cabinet.

3.1.1.1

ice maker with built-in condensing unit

appliance in which the refrigeration unit is an integral part of the cabinet

3.1.1.2

ice maker with remote condensing unit

appliance in which the compressors, condensers and liquid receivers (when required) are not supplied with the cabinet

3.1.1.3

split ice maker

appliance in which the condenser is not integrated in the main ice making unit and the condenser and piping are made in accordance with manufacturers indications using dedicated condensers

3.2 Type of condenser cooling

3.2.1

water-cooled ice maker

appliance in which the condenser is cooled by use of water

3.2.2

air-cooled ice maker

appliance in which the condenser is cooled by use of air

3.3 Type of ice

3.3.1

ice cube

single piece of ice that can have different shapes (e.g. dice, cylinder, ball, etc.) and is produced by a batch-type ice maker

3.3.2

ice flakes

ice which contains at least 70 % flaked ice (and no more than 30 % water) which is produced by a continuous-type ice maker

3.4 Type of production

3.4.1

batch-type ice maker

ice maker that has alternate freezing and harvesting periods

3.4.1.1

batch-type single cubes ice maker

ice maker that produces single ice cubes

3.4.1.2

batch-type multiple cubes ice maker

ice maker that produces multiple ice cubes

3.4.2

continuous-type ice maker

ice maker that continually freezes and harvests ice flakes at the same time

3.5

ice storage bin

factory-made container (not necessarily shipped in one package with the ice-maker) that forms or is intended to form a non-refrigerated compartment for the storage of ice

Note 1 to entry: The container is equipped with additional devices (e.g. container support, carts).

3.6

separate storage compartment

non-refrigerated compartment for the storage of ice that is separate from the ice-making mechanism

3.7

purge

blow-down

dissipation of a certain percentage of water to control the clarity of ice or to prevent scaling

3.8**ice production**

amount of ice harvested, stated in kg/24 h in multiples of 1 kg

3.9**energy consumption rate**

total energy input stated in kWh/100 kg of ice in multiples of 0,1 kWh

3.10**potable water use rate**

amount of potable water used in making ice, including purging and harvesting, stated in l/100 kg of ice in multiples of 0,1 l

3.11**cooling water use rate**

amount of cooling water used in making ice, stated in l/100 kg of ice in multiples of 0,1 l

4 Measurement of energy consumption, water consumption and ice production capacity

4.1 General

Unless otherwise specified, measurements shall be made under test conditions and with equipment set-up as specified in [4.2](#) to [4.5](#) and [Clause 5](#).

4.2 Test room

The test room walls and ceilings shall be insulated to ensure that the temperature of both the inside walls and the ceiling surface is within 2 °C of the ambient temperature.

Fluorescent or LED lighting shall be used owing to its high light output, low surface temperature and low heat load on the test room.

The air flow shall be horizontal with a speed $\leq 0,25$ m/s.

The measuring point of air speed shall be located, 300 mm upstream of the ice maker, in line with the front of the ice maker at a vertical height that is half the ice maker height (including ice maker feet and fixings) see [Figure 1](#).

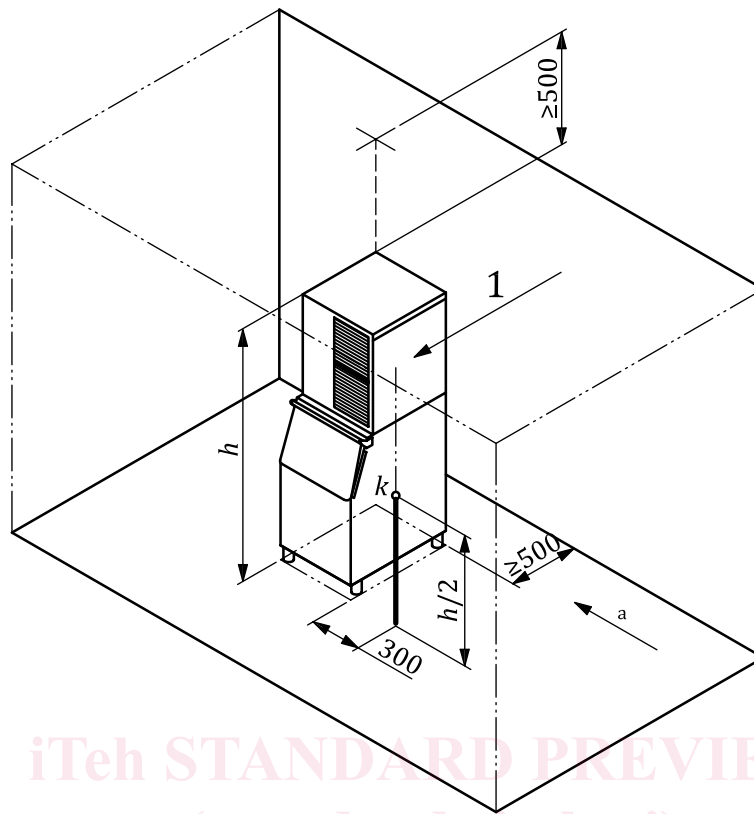

iTeh STANDARD PREVIEW
(standards.iteh.ai)

Key

- 1 climate measuring point
- h* overall height of the cabinet including feet
- k* climate measuring point detecting temperature
- a* Air flow.

Figure 1 — Test room temperature measuring point and positioning of the cabinet

4.3 Ambient temperature

The ice maker shall be tested at an ambient temperature of $32\text{ °C} \pm 1\text{ °C}$.

For a split ice maker, the condenser air inlet temperature shall be $32\text{ °C} \pm 1\text{ °C}$, with an indoor ambient temperature of $32\text{ °C} \pm 1\text{ °C}$.

With the ice maker switched off and the test room in operation, temperatures shall be measured in a vertical line through the climate measuring points. The vertical ambient temperature gradient in any metre of vertical distance from 50 mm above the floor or supporting platform to a height of 2 m, or to a height of 300 mm above the top of the cabinet, whichever is greater, shall not exceed 1,0 °C per metre.

Test room temperatures shall be measured by sensors, inserted in the centre of tinned solid copper or copper-zinc alloy cylinders having a mass of $25\text{ g} \pm 1\text{ g}$ and of minimum external area (diameter = to height = to approximately 15,2 mm).

4.4 Water supply

The water used for the test shall have an inlet temperature of $21\text{ °C} \pm 1\text{ °C}$ and the water pressure shall be according to the manufacturer’s specifications with a tolerance of $\pm 50\text{ kPa}$.

Whenever a pressure range is indicated, the tests are carried out at the mean of the pressure range with a tolerance of ± 50 kPa.

The temperature and the pressure of the supply water used for the test shall be measured within 300 mm of the machine by inserting the temperature and the pressure -measuring sensors directly into the water stream or into a test port inserted into the water pipe.

4.5 Location of unit in test room

The ice maker shall be installed according to the manufacturer's instructions and shall be positioned in the test room with a minimum clearance of 0,5 m from the ceiling and the walls.

Condenser and length and section of piping of split ice makers shall be in accordance with manufacturer instructions.

4.6 Power supply

The ice maker shall be supplied at the voltage and frequency marked on the rating plate. In case a range of voltage or frequency are indicated, the ice maker is supplied at the conditions giving the highest energy consumption.

The tolerance on power supply shall be ± 2 % for voltage and ± 1 % for frequency, in relation to the nominal values given on the marking plate or otherwise stated.

4.7 Set-up and operation of the ice maker

4.7.1 Ice maker set-up

The ice maker shall be set-up, heat exchangers and other accessories shall be connected, and the ice maker shall be adjusted in accordance with the manufacturer's instructions prior to testing.

The ice maker shall be completely assembled, with all panels, doors and lids in their normal operating positions.

Ice storage bins shall be filled approximately one-half full of ice. Ice makers that convey ice to an ice storage bin shall be tested with the minimum length of conduit that can be used.

For air-cooled ice makers with air cooling features and with air inlet(s), ambient temperature(s) shall be measured at a point centred 300 mm from each inlet. The maximum temperature difference between this temperature and the ambient room temperature(s) shall not exceed 1,0 °C. For water-cooled ice makers, not provided with air-cooling features, ambient temperature shall be measured centred 300 mm from one of the sides of the cabinet (see [Figure 1](#)).

4.7.2 Ice maker operation

After the set-up the ice maker is switched on. No changes to the test room shall be made during operation of the ice maker under test that would impact the vertical ambient temperature gradient or the ambient air movement according to [4.3](#).

4.8 Accuracy of measurement and instrumentation

The accuracy of measurement shall be as follows:

- temperature: $\pm 0,8$ °C;
- total energy: ± 2 %;
- mass: ± 2 g;

- time: ± 1 s;
- dimensions: ± 2 mm.

4.9 Test procedure

4.9.1 Simultaneous tests

Tests for energy consumption, water consumption and ice production capacity shall be undertaken simultaneously.

For temperature, measurements shall be carried out at least every 3 min.

For energy consumption, measurements shall be carried out at least every 1 min.

4.9.2 Stabilization

The ice maker shall be considered stabilized after three consecutive ice production capacity measurements with a tolerance between each ice production of ± 3 % for batch-type ice makers and after a period of not less than two hours of operation for continuous-type ice makers.

4.9.3 Ice sampling

4.9.3.1 General

After temperature stabilization, ice samples shall be collected according to the procedures described in [4.9.3.2](#) and [4.9.3.3](#).

4.9.3.2 Batch-type ice maker

The collection of ice samples for batch-type machines shall start at a preselected point in the cycle and shall end at the same point in the cycle. One cycle comprises one complete freezing period followed by one complete harvesting period. At least 5 cycles for collection of ice samples shall be performed after the 3 stabilization cycles specified in [4.9.2](#).

The intercepted ice sample shall be collected after each cycle in a perforated container (such that any water present is drained) that has been pre-cooled with the ice produced by the ice-maker whilst stored in the ice storage bin, which is not more than half volume full of ice. The ice sample shall be immediately transferred in a non-perforated container and the mass shall be measured according to [4.9.1](#).

4.9.3.3 Continuous-type ice maker

The test for continuous-type machines shall start at stabilization conditions, 5 test samples batches each lasting 20 min shall be taken in a non-perforated container precooled with the ice produced by the ice-maker whilst stored in the ice storage bin (half volume full of ice) and the mass shall be measured at the end of each 20 min period.

4.10 Recording

4.10.1 General

- a) Ambient temperature ($^{\circ}\text{C}$).
- b) Supply water temperature ($^{\circ}\text{C}$).
- c) Input voltage (V).
- d) Input frequency (Hz).