



Standard Specification for Surface Discontinuities of Bolts, Screws, and Studs, Inch and Metric Series¹

This standard is issued under the fixed designation ~~F788/F788M~~;F788; the number immediately following the designation indicates the year of original adoption or, in the case of revision, the year of last revision. A number in parentheses indicates the year of last reapproval. A superscript epsilon (ϵ) indicates an editorial change since the last revision or reapproval.

This standard has been approved for use by agencies of the Department of Defense.

1. Scope*

1.1 This specification establishes allowable limits for the various types of surface discontinuities that may occur during the manufacture and processing of bolts, screws, and studs, including heat-treated machine screws, tapping screws, and sems (the washers of screw-washer assemblies are excluded). This specification covers metric series products with nominal diameters of 4 mm and larger and with specified minimum tensile strengths of 420 MPa and higher; and inch series products with nominal diameters of No. 5 (0.1250 in.) and larger and with specified minimum tensile strengths of 60 000 psi and higher.

1.2 When the engineering requirements of the application necessitate control of surface discontinuities on bolts, screws, or studs, the purchaser shall specify conformance to ASTM Specification ~~F788/F788M~~, in the original inquiry and purchase order.

1.2.1 When the engineering requirements of the application necessitate that surface discontinuities on bolts, screws, and studs be controlled within limits closer than those specified in this specification, the purchaser shall specify the applicable limits in the original inquiry and purchase order.

1.3 The allowable limits established in this specification for metric bolts, screws, and studs with nominal diameters from 4 to 24 mm inclusive, are essentially identical with requirements given in ISO 6157/I. There are no ISO standards for surface discontinuities on any inch-series products.

1.4 The values stated in either SI units or inch-pound units are to be regarded separately as standard. The values stated in each system may not be exact equivalents; therefore, each system shall be used independently of the other. Combining values from the two systems may result in non-conformance with the standard.

2. Referenced Documents

2.1 ASTM Standards:²

[E340 Test Method for Macroetching Metals and Alloys](#)

[F1470 Practice for Fastener Sampling for Specified Mechanical Properties and Performance Inspection](#)

[F1789 Terminology for F16 Mechanical Fasteners](#)

2.2 ISO Standard:³

[ISO 6157/I Fasteners, Surface Discontinuities on Bolts, Screws and Studs](#)

3. Ordering Information

3.1 Orders for bolts, screws, and studs requiring discontinuity control shall include the following:

3.1.1 ASTM designation and date of issue of this specification.

3.1.2 Special requirements, for example, closer discontinuity limits (1.2.1) and inspection sampling plan (6.2).

4. Types of Surface Discontinuities (see Terminology **F1789** for definitions not provided)

4.1 Crack

4.1.1 *Quench Cracks*—Typical quench cracks are shown in Fig. 1. Limits are specified in 5.2.

4.1.2 *Forging Cracks*—Typical forging cracks are shown in Fig. 2. Limits are specified in 5.3.

4.2 *Burst*—Typical bursts are shown in Fig. 3. Limits are specified in 5.4.

4.2.1 *Shear Burst*—A shear burst is an open break in the metal located at approximately a 45° angle to the product axis. Shear bursts occur most frequently at the periphery of products having flanged or circular heads. Shear bursts may also occur on the sides of hex-head products. Typical shear bursts are shown in Fig. 3. Limits are specified in 5.4.

4.3 *Seam*—Typical seams are shown in Fig. 4. Limits are specified in 5.5.

*A Summary of Changes section appears at the end of this standard

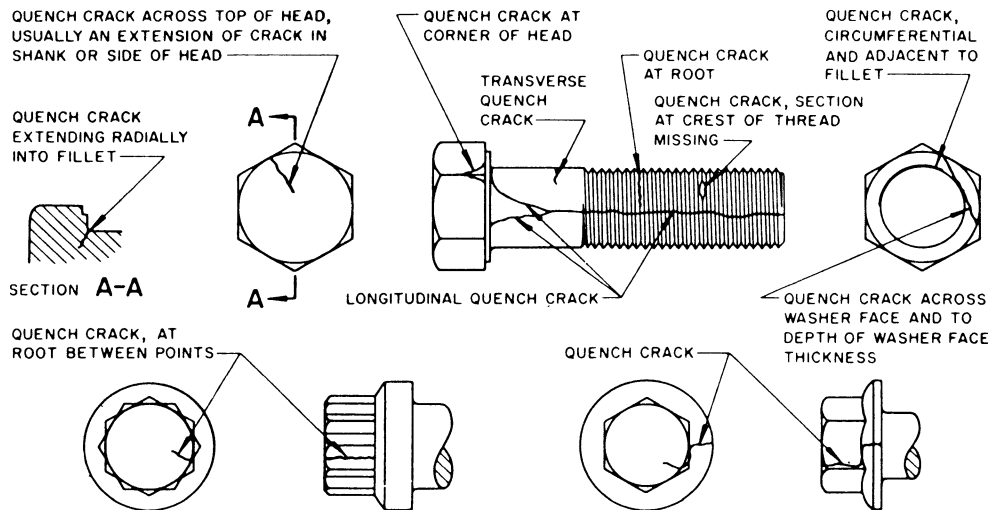

FIG. 1 Typical Quench Cracks

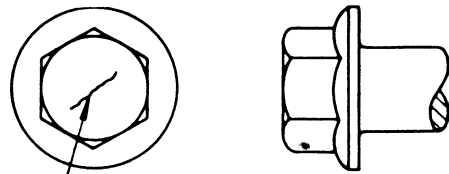

FIG. 2 Typical Forging Cracks

4.4 *Fold*—Typical folds are shown in Fig. 5 a,b, and c. Limits are specified in 5.6.

4.5 *Thread Lap*—Limits are specified in Supplementary Requirement S.1.1.

4.6 *Void*—A void is a shallow pocket or hollow on the surface of a bolt or screw due to nonfilling of metal during forging. Voids are produced by marks or impressions of chips (shear burrs) or by rust formation on the raw material. They are not planished during forging. Typical voids are shown in Fig. 6. Limits are specified in 5.7.

4.7 *Tool Marks*—Tool marks are longitudinal or circumferential grooves of shallow depth produced by the movement of manufacturing tools over the surface of the bolt or screw. Typical tool marks are shown in Fig. 7. Limits are specified in 5.8.

4.8 *Gouge and Nick*—an indentation on the surface of a fastener produced by impact with another fastener, or from processing equipment during manufacture, handling or transport.

5. Allowable Limits

5.1 *Letter Definitions*—Throughout the following requirements, *D* designates the nominal size (basic major diameter of thread) of bolts, screws, and studs, except for products with shoulders, in which case *D* designates the largest shoulder diameter; and *D_c* designates flange diameter (specified maximum) or head diameter (specified maximum) of circular head products. For metric series products, *D* and *D_c* are in millimetres; for inch-series products, *D* and *D_c* are in inches.

5.2 *Quench Cracks*—Quench cracks of any depth, any length, or in any location are not permitted.

5.3 *Forging Cracks*—Forging cracks on the top of the head of bolts and screws are permitted, provided that (a) no crack shall have a length exceeding 1.0 *D*, and (b) no crack shall have a width or depth exceeding 0.04 *D*. See Note 1.

NOTE 1—Forging cracks within the limits of this specification may be unsightly, but do not affect the mechanical properties or functional requirements of the bolt.

¹ This specification is under the jurisdiction of ASTM Committee F16 on Fasteners and is the direct responsibility of Subcommittee F16.93 on Quality Assurance Provisions for Fasteners.

Current edition approved Nov. 1, 2008; Oct. 1, 2012. Published November 2008; November 2012. Originally approved in 1982. Last previous edition approved in 2007 as F788/F788M – 07; F788/F788M – 08. DOI: 10.1520/F0788-F0788M-08-10.1520/F0788-12.

² For referenced ASTM standards, visit the ASTM website, www.astm.org, or contact ASTM Customer Service at service@astm.org. For *Annual Book of ASTM Standards* volume information, refer to the standard's Document Summary page on the ASTM website.

³ Available from American National Standards Institute (ANSI), 25 W. 43rd St., 4th Floor, New York, NY 10036, http://www.ansi.org.

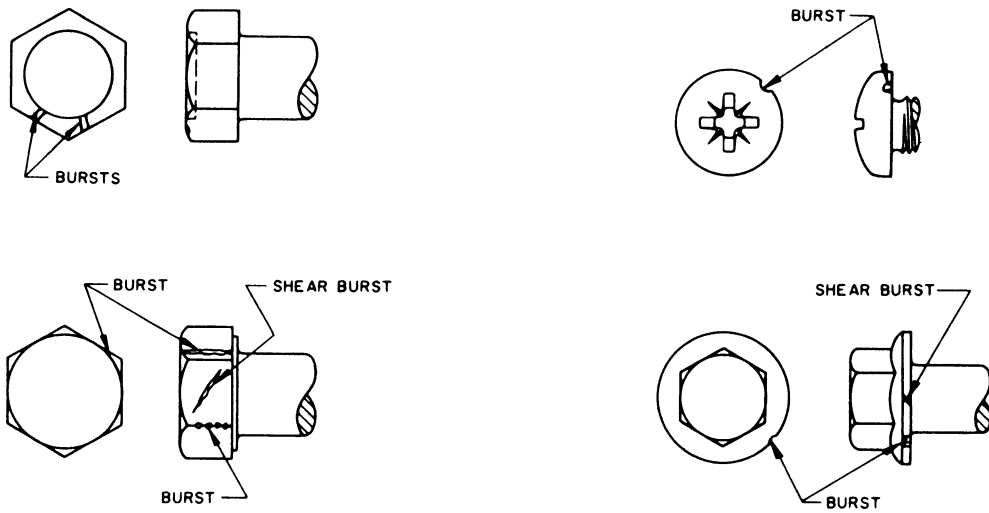

FIG. 3 Typical Bursts and Shear Bursts

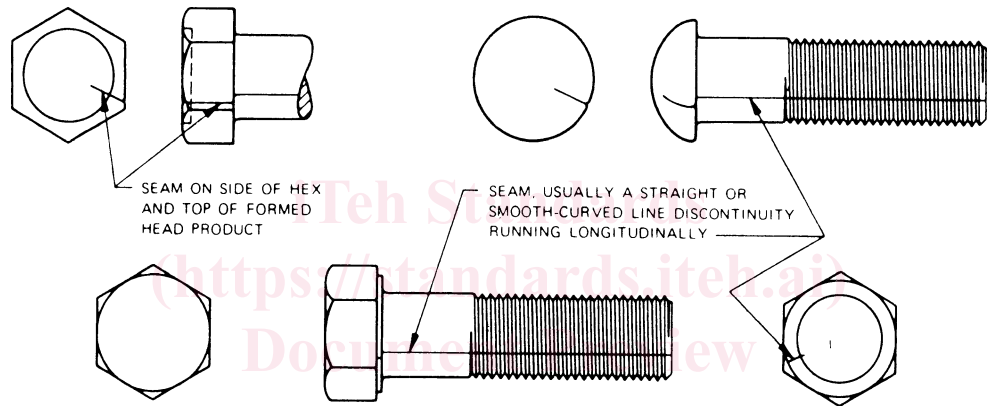
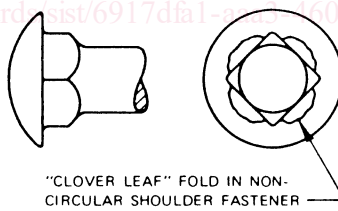

FIG. 4 Typical Seams



"CLOVER LEAF" FOLD IN NON-CIRCULAR SHOULDER FASTENER

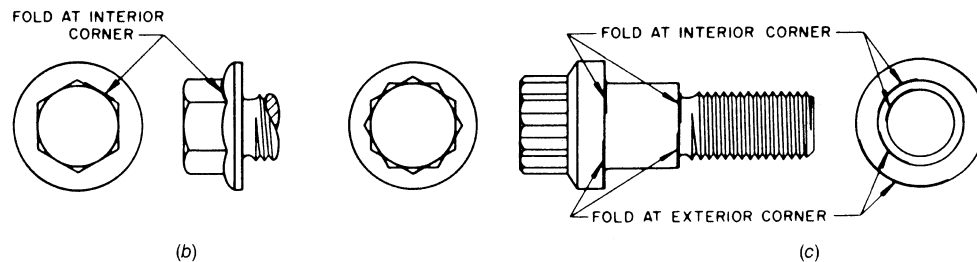

FIG. 5 Typical Folds

5.4 Bursts and Shear Bursts (see Note 2):

5.4.1 For hex-head bolts and screws, bursts and shear bursts are permitted, provided that: (1) no burst or shear burst in the flats extends into the crown (chamfer) circle on the top of the head or into the underhead bearing circle, (2) no burst or shear burst located at the intersection of two wrenching flats reduces the width across corners below its specified minimum, and (3) no burst or shear burst has a width or depth greater than $.06D$ but not to exceed .062 in. (1.6 mm).