

INTERNATIONAL
STANDARD

ISO
22241-4

Third edition

**Diesel engines — NO_x reduction agent
AUS 32 —**

**Part 4:
Refilling interface**

Moteurs diesel — Agent AUS 32 de réduction des NO_x —

Partie 4: Interface de remplissage

iTeh STANDARD PREVIEW
(standards.iteh.ai)

[ISO 22241-4](https://standards.iteh.ai/catalog/standards/sist/c8cc8a12-6406-4b1f-bbad-fae1500bcb9d/iso-22241-4)

<https://standards.iteh.ai/catalog/standards/sist/c8cc8a12-6406-4b1f-bbad-fae1500bcb9d/iso-22241-4>

PROOF / ÉPREUVE



Reference number
ISO 22241-4:2023(E)

© ISO 2023

iTeh STANDARD PREVIEW
(standards.iteh.ai)

ISO 22241-4

<https://standards.iteh.ai/catalog/standards/sist/c8cc8a12-6406-4b1f-bbad-fae1500bcb9d/iso-22241-4>



COPYRIGHT PROTECTED DOCUMENT

© ISO 2023

All rights reserved. Unless otherwise specified, or required in the context of its implementation, no part of this publication may be reproduced or utilized otherwise in any form or by any means, electronic or mechanical, including photocopying, or posting on the internet or an intranet, without prior written permission. Permission can be requested from either ISO at the address below or ISO's member body in the country of the requester.

ISO copyright office
CP 401 • Ch. de Blandonnet 8
CH-1214 Vernier, Geneva
Phone: +41 22 749 01 11
Email: copyright@iso.org
Website: www.iso.org

Published in Switzerland

Contents

	Page
Foreword.....	iv
1 Scope.....	1
2 Normative references.....	1
3 Terms and definitions.....	1
4 Requirements.....	3
4.1 Functional requirements.....	3
4.2 Filler neck.....	4
4.3 Inlet adapter.....	5
4.3.1 Inlet adapter with neodymium-iron-boron (NdFeB) magnet ring.....	6
4.3.2 Inlet adapter with alternative equivalent magnet field.....	6
4.4 Filler cap.....	10
4.5 Filler nozzle.....	11
4.6 Minimum free space for refilling.....	12
Annex A (normative) Compatibility conditions for sealed refilling systems.....	15
Bibliography.....	18

iTeh STANDARD PREVIEW (standards.iteh.ai)

[ISO 22241-4](https://standards.iteh.ai/catalog/standards/sist/c8cc8a12-6406-4b1f-bbad-fae1500bcb9d/iso-22241-4)

<https://standards.iteh.ai/catalog/standards/sist/c8cc8a12-6406-4b1f-bbad-fae1500bcb9d/iso-22241-4>

Foreword

ISO (the International Organization for Standardization) is a worldwide federation of national standards bodies (ISO member bodies). The work of preparing International Standards is normally carried out through ISO technical committees. Each member body interested in a subject for which a technical committee has been established has the right to be represented on that committee. International organizations, governmental and non-governmental, in liaison with ISO, also take part in the work. ISO collaborates closely with the International Electrotechnical Commission (IEC) on all matters of electrotechnical standardization.

The procedures used to develop this document and those intended for its further maintenance are described in the ISO/IEC Directives, Part 1. In particular, the different approval criteria needed for the different types of ISO document should be noted. This document was drafted in accordance with the editorial rules of the ISO/IEC Directives, Part 2 (see www.iso.org/directives).

ISO draws attention to the possibility that the implementation of this document may involve the use of (a) patent(s). ISO takes no position concerning the evidence, validity or applicability of any claimed patent rights in respect thereof. As of the date of publication of this document, ISO had not received notice of (a) patent(s) which may be required to implement this document. However, implementers are cautioned that this may not represent the latest information, which may be obtained from the patent database available at www.iso.org/patents. ISO shall not be held responsible for identifying any or all such patent rights.

Any trade name used in this document is information given for the convenience of users and does not constitute an endorsement.

For an explanation of the voluntary nature of standards, the meaning of ISO specific terms and expressions related to conformity assessment, as well as information about ISO's adherence to the World Trade Organization (WTO) principles in the Technical Barriers to Trade (TBT), see www.iso.org/iso/foreword.html.

This document was prepared by Technical Committee ISO/TC 22, *Road vehicles*, Subcommittee SC 34, *Pulsion, powertrain and powertrain fluids*.

This third edition of ISO 22241-4 cancels and replaces the second edition (ISO 22241-4:2019), which has been technically revised.

The main changes are as follows:

- an alternative magnetic function design has been added;
- [Table 1](#) has been editorially and technically revised.

A list of all parts in the ISO 22241 series can be found on the ISO website.

Any feedback or questions on this document should be directed to the user's national standards body. A complete listing of these bodies can be found at www.iso.org/members.html.

Diesel engines — NO_x reduction agent AUS 32 —

Part 4: Refilling interface

1 Scope

This document specifies the refilling interface for the NO_x reduction agent AUS 32 in conformance with ISO 22241-1, which is needed to operate converters with a selective catalytic reduction (SCR) exhaust treatment system.

This document specifies the minimum functional and geometric requirements of an open refilling system, in order to ensure compatibility between the on-board refilling system and the off-board refilling system. Compatibility conditions for a sealed refilling system are provided in [Annex A](#).

This document applies to commercial vehicles and buses as defined in ISO 3833 and having a gross vehicle mass of more than 3,5 t, designed to use stationary off-board refilling systems. This document also applies to the nozzle of stationary off-board refilling systems.

NOTE Throughout this document, the term “NO_x reduction agent AUS 32” is abbreviated to “AUS 32”.

2 Normative references

The following documents are referred to in the text in such a way that some or all of their content constitutes requirements of this document. For dated references, only the edition cited applies. For undated references, the latest edition of the referenced document (including any amendments) applies.

ISO 2575, *Road vehicles — Symbols for controls, indicators and tell-tales*

ISO 22241-1, *Diesel engines — NO_x reduction agent AUS 32 — Part 1: Quality requirements*

ISO 22241-3, *Diesel engines — NO_x reduction agent AUS 32 — Part 3: Handling, transportation, and storage*

3 Terms and definitions

For the purposes of this document, the terms and definitions given in ISO 22241-1 and the following apply.

ISO and IEC maintain terminology databases for use in standardization at the following addresses:

- ISO Online browsing platform: available at <https://www.iso.org/obp>
- IEC Electropedia: available at <https://www.electropedia.org/>

3.1

refilling system

off-board system and on-board system, including their refilling interface, for dispensing AUS 32 into the on-board tank of the *vehicle* (3.12)

3.2

off-board refilling system

stationary equipment for dispensing AUS 32 into the on-board tank of the *vehicle* (3.12), consisting typically of tank, pump, hose and *filler nozzle* (3.3)

3.3

filler nozzle

interfacing part of the *off-board refilling system* (3.2), which allows the operator to control the flow of AUS 32 during the filling, consisting of a nozzle spout with a defined interface geometry and an automatic shut-off system

3.4

on-board refilling system

equipment of the *vehicle* (3.12) necessary for refilling AUS 32 and consisting typically of an *inlet adapter* (3.6), *filler neck* (3.5), *filler cap* (3.7) and tank

3.5

filler neck

interfacing part of the *on-board refilling system* (3.4) where the opening is formed by the *inlet adapter* (3.6) to allow the tank to be refilled

3.6

inlet adapter

permanently fixed part of the *filler neck* (3.5), having a defined interface geometry and incorporating a magnet ring for preventing misfilling of AUS 32 into the fuel tank

3.7

filler cap

part which is fitted to the *filler neck* (3.5) to prevent *spillage* (3.11) as well as to minimize contamination of AUS 32 and which is temporarily opened or removed for refilling

3.8

open refilling system

universal *refilling system* (3.1) for which gas tightness between the *filler nozzle* (3.3) and the *filler neck* (3.5) is not required

Note 1 to entry: The open refilling system permits, for example, refilling using a small volume container.

3.9

sealed refilling system

specific *refilling system* (3.1) where the connection between the *filler nozzle* (3.3) and the *filler neck* (3.5) is gas-tight

3.10

canister

container of size one to ten litres capacity, with spout, used to refill the on-board tank of the *vehicle* (3.12)

3.11

spillage

quantity of fluid that escapes from the *filler nozzle* (3.3) to the atmosphere after the nozzle has shut off

3.12

vehicle

commercial vehicle or bus as defined in ISO 3833 and having a gross vehicle mass of more than 3,5 t, designed to use a stationary *off-board refilling system* (3.2)

3.13

magnet resistance force

F_{res}

force measured using the alternative equivalent magnet field test (4.3.2)

Note 1 to entry: The “res” subscript is the abbreviation for resistance.

4 Requirements

4.1 Functional requirements

The on-board refilling system and the off-board refilling system shall comply with the basic functional requirements specified in [Table 1](#). For sealed refilling system the additional requirements in [Annex A](#) shall apply.

Table 1 — Basic functional requirements

No.	Characteristic	Requirement	Remark
1	Maximum flow rate range	$20 \text{ l/min} \leq x \leq 40 \text{ l/min}$	Flow rates do not apply to: <ul style="list-style-type: none"> — canister filling; — production line filling.
2	Automatic shut-off of filler nozzle	Feature to protect against overfill is required.	For example, a nozzle in conformance with EN 13012
3	Maximum filling level in AUS 32 on-board tank	The automatic shut-off system of the nozzle shall be used to protect against filling above maximum level. The on-board tank shall be designed to allow for expansion of AUS 32.	High volume expansion of AUS 32 during freezing (approximately 7 %)
4	Spillage	< 30 ml per refilling with filler neck angles from the horizontal between 50° and 90° < 50 ml per refilling with filler neck angles from the horizontal between 30° and 50°	To minimize the effects of spilled AUS 32 on the equipment
5	Ventilation during refilling	Feature required on AUS 32 on-board tank.	—
6	Operational temperature range	–30 °C to +80 °C for on-board components –20 °C to +40 °C for off-board components	For specific regions, the temperature range specified may not be sufficient or be excessive. In such cases, a wider or more narrow temperature range, representative of that specific region, may be considered.
7	Misfilling of AUS 32 into the diesel fuel tank	≤ 80 ml per filling trial	The filler nozzle with magnet switch as specified in 4.5 , or equivalent device, will prevent misfilling.
8	Misfilling of fuel into the AUS 32 on-board tank	Feature required to prevent dispensing of diesel fuel or petrol in AUS 32 on-board tank.	The inlet adapter diameter specified in 4.3 does not allow a diesel fuel or petrol nozzle to enter.
9	Materials	Materials in contact with AUS 32 shall be compatible with AUS 32 to avoid contamination of AUS 32 as well as corrosion of the devices used.	Suitable materials in accordance with ISO 22241-3 should be selected.
10	Freezing of AUS 32	Provide protection at the service station in accordance with operational temperature range. Vehicle parts shall be designed to cope with freezing and thawing in accordance with operational temperature range.	AUS 32 freezes at –11,5 °C and has a volume increase of approximately 7 %.
<p>^a With a magnet resistance force F_{res} lower than 0,5 N it is not assured that the misfilling prevention of the nozzle will be activated properly in case of crystallized AUS 32, wear and tear of the nozzle spout and dusty environment.</p> <p>^b Recommendations only.</p>			

Table 1 (continued)

No.	Characteristic	Requirement	Remark
11	Cleanliness	All surfaces of on-board and off-board equipment in direct contact with AUS 32 shall be free of foreign matter (e.g. fuel, oil, grease, detergent, dust, and any other substance) in accordance with ISO 22241-3. Cleanliness level for the components of the on-board refilling system shall be agreed between vehicle and component manufacturers, in conformance with state-of-the-art.	—
12	Reliability and durability	The filler neck, inlet adapter and filler cap shall be designed and manufactured to be fully functional during the vehicle lifetime without any service, adjustment or replacement.	—
13	Magnet ring ^a	Either use a magnet according to Table 3 or the magnet resistance force measured according to 4.3.2 shall be $F_{res} \geq 0,5 \text{ N}$ for each bore tested, refer to Figure 4 .	In the case of using a magnet different from Table 3 the resulting force from the filler neck magnet on a test cylinder shall be measured according to 4.3.2 .
14	Crystallization ^b	Protection recommended	Contact with air should be minimized.
15	Marking ^b	Symbol shall be as specified in ISO 2575 or equivalent national standard.	Blue is the recommended colour for filler caps.
^a With a magnet resistance force F_{res} lower than 0,5 N it is not assured that the misfilling prevention of the nozzle will be activated properly in case of crystallized AUS 32, wear and tear of the nozzle spout and dusty environment.			
^b Recommendations only.			

4.2 Filler neck

The filler neck allows the vehicle manufacturer or any authorized person to install or remove an inlet adapter that can accommodate an open refilling system. For dimensional details of the filler neck, see [Figure 1](#) and [Table 2](#).

The geometric location and orientation of the filler neck on the vehicle should be specified by the vehicle manufacturer, taking into account the free space required for the proper application of the filler nozzle (see [4.6](#)).

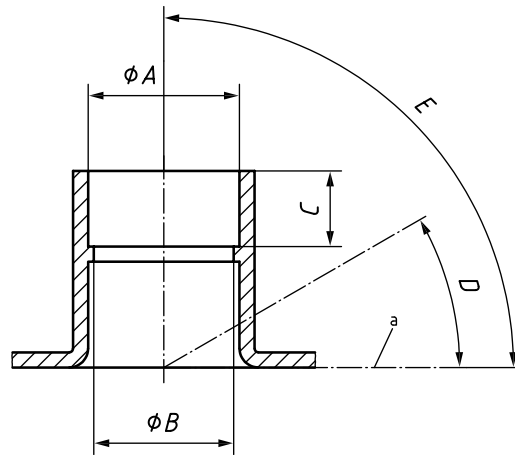

a Horizontal.

Figure 1 — Filler neck

Table 2 — Dimensions of the filler neck

Symbol	Parameter	Dimension
ϕA	Diameter inlet or upper stop	$\geq 39,5$ mm
ϕB	Diameter upper support	≥ 37 mm
C	Height upper stop	≤ 48 mm
D	Filler neck angle from horizontal ^a	$\geq 30^{\text{ob}}$
E		$\leq 90^{\circ}$

^a An angle between 50° and 90° is recommended to minimize spillage (see [Table 1](#)).

^b If, due to body design restrictions, an angle smaller than 30° is chosen by the designer, spillage will typically be greater and may exceed the value specified in [Table 1](#), in which case the function of the nozzle may be limited.

4.3 Inlet adapter

The inlet adapter shall be designed to fit inside the filler neck. The internal diameter of the inlet adapter shall prevent a filler nozzle spout greater than 20,0 mm in diameter from entering the inlet adapter.

The inlet adapter shall be equipped with a magnet ring as shown in [Figure 2](#). The magnet shall either be according to [4.3.1](#) or [4.3.2](#).

By proper installation of the filler neck and its inlet adapter on the vehicle, the vehicle manufacturer shall ensure that the magnet switch of the AUS 32 filling nozzle is only activated when this nozzle is inserted in the filler neck for aqueous urea solution and not when inserted in any other filler neck (e.g. for diesel fuel, injection water, etc.). Otherwise a misfilling is possible.

Dimensions in millimetres

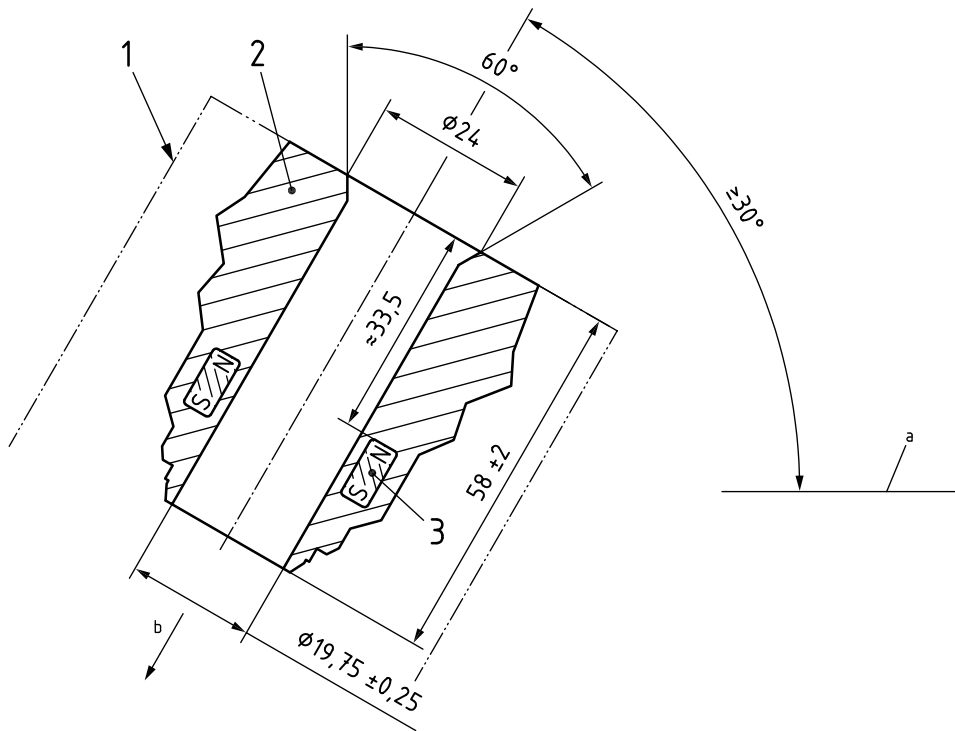

Key

- 1 filler neck
- 2 inlet adapter
- 3 magnet ring

- a Horizontal.
- b Flow direction.

iTeh STANDARD PREVIEW
(standards.iteh.ai)

ISO 22241-4
<https://standards.iteh.ai/catalog/standards/iso-6406-4b1f-bbad-fae1500bcb9d/iso-22241-4> **Figure 2 — Inlet adapter**

4.3.1 Inlet adapter with neodymium-iron-boron (NdFeB) magnet ring

If this option is chosen, the inlet adapter shall be equipped with a magnet ring having the characteristics specified in [Table 3](#).

Table 3 — Magnet ring characteristics

Parameter		Requirements
Dimensions	outer diameter	34 mm
	inner diameter	24 mm
	height	10 mm
Material		NdFeB
Magnet parameter	remanence	1,2 T to 1,3 T
	coercivity	800 kA/m to 900 kA/m
Orientation		North pole pointing outwards from the tank

4.3.2 Inlet adapter with alternative equivalent magnet field

To ensure that the nozzle’s misfilling prevention is deactivated by the filler neck magnet and the AUS 32 delivery through the nozzle becomes possible, a certain magnetic force is necessary.

The characteristics of the magnet shall be in accordance with [Table 3](#) with the north pole pointing outwards from the tank.

When using the procedure described in 4.3.2.1 verify that the chosen alternative magnet solution is capable to activate the magnet switch in the nozzle spout.

4.3.2.1 Determination of the resulting force from the filler neck magnet

4.3.2.1.1 Test equipment

The following test equipment shall be used:

- a) test cylinder made of steel material 11SMn30 (see ISO 683-4) (see Figure 3);

Dimensions in millimetres

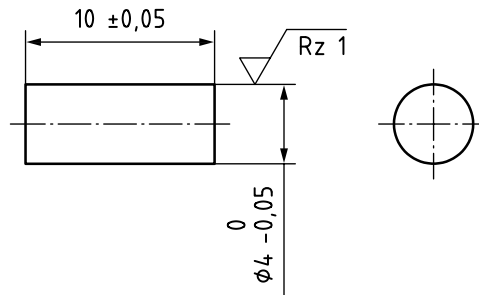
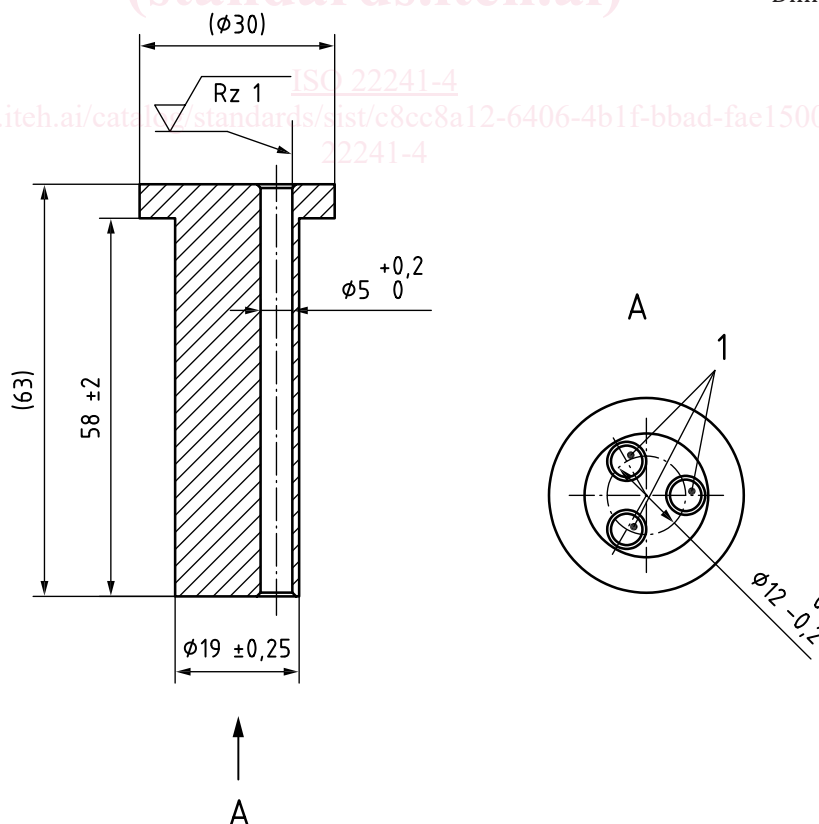

Figure 3 — Test cylinder for magnet efficiency

- b) nozzle spout equivalent made of aluminium (see Figure 4);

Dimensions in millimetres



Key

- 1 bores

Figure 4 — Sketch of spout equivalent