



Designation: **A488/A488M—10 A488/A488M – 12**

Standard Practice for Steel Castings, Welding, Qualifications of Procedures and Personnel¹

This standard is issued under the fixed designation A488/A488M; the number immediately following the designation indicates the year of original adoption or, in the case of revision, the year of last revision. A number in parentheses indicates the year of last reapproval. A superscript epsilon (ϵ) indicates an editorial change since the last revision or reapproval.

This standard has been approved for use by agencies of the Department of Defense.

1. Scope*

1.1 This practice covers the qualification of procedures, welders, and operators for the fabrication and repair of steel castings by electric arc welding.

1.1.1 Qualifications of a procedure and either or both the operator or welder under Section IX of the ASME Boiler and Pressure Vessel Code shall automatically qualify the procedure and either or both the operator or welder under this practice. P-number designations in the ASME grouping of base metals for qualification may be different than the category numbers listed in **Table 1**. Refer to **Appendix XI** for a comparison of ASTM category numbers with the corresponding ASME P-Number designations.

1.2 Each manufacturer or contractor is responsible for the welding done by his organization and shall conduct the tests required to qualify his welding procedures, welders, and operators.

1.3 Each manufacturer or contractor shall maintain a record of welding procedure qualification tests (**Fig. 1**), welder or operator performance qualification tests (**Fig. 2**), and welding procedure specification (**Fig. 3**), which shall be made available to the purchaser's representative on request.

1.4 The values stated in either SI units or inch-pound units are to be regarded separately as standard. The values stated in each system may not be exact equivalents; therefore, each system shall be used independently of the other. Combining values from the two systems may result in non-conformance with the standard.

1.4.1 *SI Units*—Within the text, the SI units are shown in brackets.

1.5 *This standard does not purport to address all of the safety concerns, if any, associated with its use. It is the responsibility of the user of this standard to establish appropriate safety and health practices and determine the applicability of regulatory limitations prior to use.*

2. Referenced Documents

2.1 *ASTM Standards*:²

[A27/A27M Specification for Steel Castings, Carbon, for General Application](#)

[A128/A128M Specification for Steel Castings, Austenitic Manganese](#)

[A148/A148M Specification for Steel Castings, High Strength, for Structural Purposes](#)

[A216/A216M Specification for Steel Castings, Carbon, Suitable for Fusion Welding, for High-Temperature Service](#)

[A217/A217M Specification for Steel Castings, Martensitic Stainless and Alloy, for Pressure-Containing Parts, Suitable for High-Temperature Service](#)

[A297/A297M Specification for Steel Castings, Iron-Chromium and Iron-Chromium-Nickel, Heat Resistant, for General Application](#)

[A351/A351M Specification for Castings, Austenitic, for Pressure-Containing Parts](#)

[A352/A352M Specification for Steel Castings, Ferritic and Martensitic, for Pressure-Containing Parts, Suitable for Low-Temperature Service](#)

[A356/A356M Specification for Steel Castings, Carbon, Low Alloy, and Stainless Steel, Heavy-Walled for Steam Turbines](#)

¹ This practice is under the jurisdiction of ASTM Committee A01 on Steel, Stainless Steel and Related Alloys and is the direct responsibility of Subcommittee A01.18 on Castings.

Current edition approved April 1, 2010. Nov. 1, 2012. Published April 2010. December 2012. Originally approved in 1963. Last previous edition approved in 2009 as A488/A488M—09. A488/A488M—10. DOI: 10.1520/A0488_A0488M-10.1520/A0488_A0488M-12.

² For referenced ASTM standards, visit the ASTM website, www.astm.org, or contact ASTM Customer Service at service@astm.org. For *Annual Book of ASTM Standards* volume information, refer to the standard's Document Summary page on the ASTM website.

*A Summary of Changes section appears at the end of this standard



TABLE 1 Categories of Base Materials

Category Number	Material Description	ASTM Specification	Grades
1	Carbon steel (carbon less than 0.35 %, tensile strength less than or equal to 70 ksi [480 MPa]).	A27/A27M	all grades
		A216/A216M A352/A352M A356/A356M A732/A732M A757/A757M A958	WCA, WCB LCB, LCA 1 1A, 2A A1Q SC 1020, SC 1025, SC 1030, CLASSES 65/35, 70/36
2	Carbon steel (tensile strength greater than 70 ksi [480 MPa]). Carbon-manganese steel (tensile strength equal to or greater than 70 ksi but less than 90 ksi [620 MPa]).	A148/A148M	80-40
		A216/A216M A352/A352M A732/A732M A757/A757M A958	WCC LCC 2Q, 3A A2Q SC 1030, SC 1040, SC 1045, CLASSES 80/40, 80/50
3	Carbon and carbon-manganese steel (tensile strength equal to or greater than 90 ksi [620 MPa]).	A732/A732M	3Q, 4A, 4Q, 5N
		A958	SC 1045, CLASSES 90/60, 105/85, 115/95
4	Low-alloy steel (annealed, normalized, or normalized and tempered. Tensile strength less than 85 ksi [585 MPa]).	A148/A148M	80-50
		A217/A217M A352/A352M A356/A356M A389/A389M A487/A487M A757/A757M A958	WC1, WC4, WC5, WC6, WC9 LC1, LC2, LC3, LC4 2, 5, 6, 8 C23, C24 11A, 12A, 16A B2N, B3N, B4N SC 4130, SC 4140, SC 8620, SC 8625, SC 8630, CLASSES 65/35, 70/36, 80/40, 80/50
5	Low-alloy steel (annealed, normalized, or normalized and tempered. Tensile strength equal to or greater than 85 ksi [585 MPa]).	A148/A148M	90-60, 105-85
		A217/A217M A356/A356M A487/A487M A732/A732M A757/A757M A958	C5, C12, C12A, WC11 9, 10, 12 1A, 1C, 2A, 2C, 4A, 4C, 6A, 8A, 9A, 9C, 10A, 13A 6N, 15A D1N1, D1N2, D1N3, E2N1, E2N2, E2N3 SC 4340, CLASSES 90/60, 105/85
6	Low-alloy steel (quenched and tempered)	A148/A148M	90-60, 105-85, 115-95, 130-115, 135-125, 150-135, 160-145, 165-150, 165-150L, 210-180, 210-180L, 260-210, 260-210L
		A352/A352M A487/A487M A732/A732M A757/A757M A958	LC2-1, LC1, LC2, LC3, LC4, LC9 1B, 1C, 2B, 2C, 4B, 4C, 4D, 4E, 6B, 7A, 8B, 8C, 9A, 9B, 9C, 9D, 9E, 10B, 11B, 12B, 13B, 14A 7Q, 8Q, 9Q, 10Q, 11Q, 12Q, 13Q, 14Q B2Q, B3Q, B4Q, C1Q, D1Q1, D1Q2, D1Q3, E1Q, E2Q1, E2Q2, E2Q3 SC 4140, SC 4130, SC 4340, SC 8620, SC 8625, SC 8630, CLASSES 115/95, 130/115, 135/125, 150/135, 160/145, 165/150, 210/180
7	Ferritic stainless steel	A743/A743M	CB-30, CC-50
8	Martensitic stainless steel	A217/A217M A352/A352M A356/A356M A487/A487M	CA-15 CA6NM CA6NM CA15-A, CA15-B, CA15-C, CA15-D, CA15M-A, CA6NM-A, CA6NM-B
		A743/A743M A757/A757M	CA-15, CA-15M, CA6NM, CA-40, CA6N, CB6 E3N
9	Low-carbon austenitic stainless steel (carbon equal to or less than 0.03 %)	A351/A351M	CF-3, CF-3A, CF-3M, CF-3MA, CF-3MN, CK-3MCUN, CG3M, CN3MN
		A743/A743M	CF-3, CF-3M, CF-3MN, CK-3MCUN, CN-3M, CG3M, CN3MN
		A744/A744M	CF-3, CF-3M, CK-3MCUN, CG3M, CN3MN
10	Unstabilized austenitic stainless steel (carbon greater than 0.03 %)	A351/A351M	CE-8MN, CF-8, CF-8A, CF-8M, CF-10, CF-10M, CG-8M, CH-8, CH-10, CH-20, CG6MMN, CF10S1MNN, CE20N
		A447/A447M	Type I



TABLE 1 Continued

Category Number	Material Description	ASTM Specification	Grades
		A743/A743M	CF-8, CG-12, CF-20, CF-8M, CF-16F, CF10SMNN, CH-20, CG-8M, CE-30, CG6MMN, CH10, CF16Fa
		A744/A744M	CF-8, CF-8M, CG-8M
11	Stabilized austenitic stainless steel	A297/A297M	HG10MNM
41	Stabilized austenitic stainless steel	A351/A351M	CF-8C, CF-10MC, CK-20, HK-30, HK-40, HT-30,
		A351/A351M	CF-8C, CF-10MC, CK-20, HK-30, HK-40, HT-30, CN-7M, CT-15C
		A447/A447M	Type II
		A743/A743M	CF-8C, CN-7M, CN-7MS, CK-20
		A744/A744M	CF-8C, CN-7M, CN-7MS
12	Duplex (austenitic-ferritic) stainless steel	A351/A351M	CD3MWCuN, CD-4MCU
		A872/A872M	J93183, J93550
		A890/A890M	1A, 1B, 2A, 3A, 4A, 5A, 6A
		A995/A995M	1B, 2A, 3A, 4A, 5A, 6A
13	Precipitation-hardened austenitic stainless steel	A747/A747M	CB7CU-1, CB7CU-2
14	Nickel-base alloys	A494/A494M	CW-12MW, CY-40 Class 1, CY-40 Class 2, CZ-100, M-35-1, M-35-2, M-30C, N-12MV, N-7M, CW-6M, CW-2M, CW-6MC, CX-2MW, CU5MCUC
		A990	CW2M
15	Steel Castings, Austenitic Manganese	A128/A128M	A, B-1, B-2, B-3, B-4, C, D, E-1, E-2, F

[A370 Test Methods and Definitions for Mechanical Testing of Steel Products](#)

[A389/A389M Specification for Steel Castings, Alloy, Specially Heat-Treated, for Pressure-Containing Parts, Suitable for High-Temperature Service](#)

[A447/A447M Specification for Steel Castings, Chromium-Nickel-Iron Alloy \(25-12 Class\), for High-Temperature Service](#)

[A487/A487M Specification for Steel Castings Suitable for Pressure Service](#)

[A494/A494M Specification for Castings, Nickel and Nickel Alloy](#)

[A732/A732M Specification for Castings, Investment, Carbon and Low Alloy Steel for General Application, and Cobalt Alloy for High Strength at Elevated Temperatures](#)

[A743/A743M Specification for Castings, Iron-Chromium, Iron-Chromium-Nickel, Corrosion Resistant, for General Application](#)

[A744/A744M Specification for Castings, Iron-Chromium-Nickel, Corrosion Resistant, for Severe Service](#)

[A747/A747M Specification for Steel Castings, Stainless, Precipitation Hardening](#)

[A757/A757M Specification for Steel Castings, Ferritic and Martensitic, for Pressure-Containing and Other Applications, for Low-Temperature Service](#)

[A872/A872M Specification for Centrifugally Cast Ferritic/Austenitic Stainless Steel Pipe for Corrosive Environments](#)

[A890/A890M Specification for Castings, Iron-Chromium-Nickel-Molybdenum Corrosion-Resistant, Duplex \(Austenitic/Ferritic\) for General Application](#)

[A958 Specification for Steel Castings, Carbon and Alloy, with Tensile Requirements, Chemical Requirements Similar to Standard Wrought Grades](#)

[A990 Specification for Castings, Iron-Nickel-Chromium and Nickel Alloys, Specially Controlled for Pressure Retaining Parts for Corrosive Service](#)

[A995/A995M Specification for Castings, Austenitic-Ferritic \(Duplex\) Stainless Steel, for Pressure-Containing Parts](#)

2.2 *American Society of Mechanical Engineers*:³

ASME Boiler and Pressure Vessel Code, Section IX

2.3 *American Welding Society*:⁴

ANSI/AWS 3.0 Definitions for Welding and Cutting

3. Terminology

3.1 *Definitions*—Definitions of terms relating to welding shall be in agreement with the definitions of the American Welding Society, ANSI/AWS A3.0.

³ Available from American Society of Mechanical Engineers (ASME), ASME International Headquarters, Three Park Ave., New York, NY 10016-5990, <http://www.asme.org>.

⁴ Available from American Welding Society (AWS), 550 NW LeJeune Rd., Miami, FL 33126, <http://www.aws.org>.



A488/A488M – 12

RECOMMENDED FORM FOR MANUFACTURER'S RECORD OF WELDING PROCEDURE QUALIFICATION TESTS

Procedure No. _____ Date: _____ Welding Process: _____
 Material Specification: _____ to _____ of category No. _____ to category No. _____
 Plate Thickness: _____ Thickness Range Qualified _____
 Filler Metal F Group No. _____ Weld Deposit A-Group No.: _____
 Flux Designation: _____ Gas Composition: _____
 Gas Flow Rate: _____ Backing Strip, if any: _____
 Preheat Temperature Range: _____ Single or Multiple Pass: _____
 Position of Groove: _____ Filler Wire Diameter: _____
 Trade Name: _____ Type of Backing: _____
 Forehand or Backhand: _____ Amps: _____ Volts _____ Inches/min: _____
 Postheat Temperature _____ Time at Temperature _____

TENSION TEST RESULTS

Specimen No.	Width	Dimensions Thickness	Area	Ultimate Total Load, lb	Ultimate Unit Stress, psi	Nature of Failure and Location

GUIDED BEND TEST RESULTS

Specimen No.	Results	Specimen No.	Results

Welder's Name: _____ Clock No. _____ Stamp No. _____

Who by virtue of these tests meets the welder performance qualification.

Test Conducted By: _____ Test No. _____
per _____

We certify that the statements in this record are correct and that the test welds were prepared, welded, and tested in accordance with the requirements of ASTM Standard _____

Signed: _____
Manufacturer or Contractor

Date: _____

FIG. 1 Report Form 1

[ASTM A488/A488M-12](https://standards.iteh.ai/catalog/standards/sist/79b881da-a663-4b90-b443-a99d671a556e/astm-a488-a488m-12)

<https://standards.iteh.ai/catalog/standards/sist/79b881da-a663-4b90-b443-a99d671a556e/astm-a488-a488m-12>



A488/A488M – 12

RECOMMENDED FORM FOR MANUFACTURER'S OR CONTRACTOR'S RECORD OF WELDER OR OPERATOR PERFORMANCE QUALIFICATION TESTS

Welder or Operator's Name: Stamp No. _____
 Clock No. _____ Welding Process: _____
 Position: _____
 In accordance with Procedure No. _____
 Material Specification: _____ to _____ of category No. _____ to category No. _____
 Plate Thickness: _____ Range of Thickness Qualified: _____
 Filler Metal Specification No. _____ Group No. F. _____
 Filler Metal A-Group No. _____ Filler Metal Diameter _____
 Trade Name: _____ Flux Designation or Gas Analysis: _____
 Was Backing Strip Used? _____

GUIDED BEND TEST RESULTS

Specimen No.	Results	Specimen No.	Results

Test Conducted By: _____ Laboratory Test No. _____
 per _____

We certify that the statements in this record are correct and that the test welds were prepared, welded, and tested in accordance with ASTM Standard _____.

Signed: _____

Manufacturer or Contractor

Date: _____

FIG. 2 Report Form 2

iTeh Standards
 (<https://standards.iteh.ai>)
 Document Preview

[ASTM A488/A488M-12](#)

<https://standards.iteh.ai/catalog/standards/sist/79b881da-a663-4b90-b443-a99d671a556e/astm-a488-a488m-12>



REPORT FORM 3

RECOMMENDED FORM FOR WELDING PROCEDURE SPECIFICATION

1. Title

Welding of ^A steel castings.

^A Indicate general material description, such as carbon, Cr-Mo, 12 Cr, etc.

2. Specification No. _____ Rev. _____

Date _____

3. Scope

3.1 Procedure Specification No. _____ covers the welding of ^A steel castings using the ^B welding process.

^A Indicate general material description in the Title.

^B Indicate specific welding process, such as shielded metal arc, etc.

4. Base Material

4.1 The base material shall conform to the specification for ^A which is found in materials category number ^B.

^A Insert reference to ASTM designation or indicate chemical analysis and physical properties.

^B Indicate category number from Table 1.

4.2 Base material shall be in the ^A heat treated condition before welding.

^A Indicate heat treatment before welding.

5. Filler Metal

5.1 The filler metal shall conform to ANSI/AWS Specification ^A which is found in weld metal analysis group A ^B.

^A Indicate appropriate American Welding Society specification number and filler metal classification (e.g., A5.1 E7018).

^B Indicate A Number from Table 4.

5.2 Flux for submerged arc welding shall conform to the following nominal composition: ^A.

^A Indicate chemical composition or trade designation.

5.3 Shielding gas for gas shielded arc welding shall conform to the following nominal composition: ^A.

^A Indicate the single gas or proportional parts of mixed gases and flow rates.

6. Preparation of Base Material

6.1 Metal removal shall be performed by ^A.

^A Indicate method of metal removal, such as chipping, grinding, carbon arc cutting, frame cutting, etc. Also indicate whether preheat is required during metal removal.

6.2 Configuration of the weld preparation for partial penetration welds shall conform to the following geometry: ^A.

^A Indicate minimum root radius and minimum side wall angle.

6.3 Configuration of the weld preparation for full penetration welds shall conform to the following geometry: ^A.

^A Indicate minimum side wall angle.

6.4 Backing plates shall be used for welding full penetration welds.

Backing plates shall be made from ^A steel and shall fit the back of the cavity with a minimum gap of ^B.

^A Indicate material of backing plate.

^B Indicate dimension of maximum gap.

6.5 Surfaces of the weld preparation shall be cleaned of all oil, grease, dirt, scale, slag, shot blasting grit, or any foreign material which may be harmful to the quality of the weld. Surfaces of backing plates when used shall also meet the same cleanliness requirements.

6.6 All surfaces of the weld preparation shall be inspected as follows: ^A.

^A Indicate type of inspection.

7. Preheat

7.1 Preheat and interpass temperature shall be maintained in the range from ^A to ^B during ^C.

^A Indicate minimum temperature.

^B Indicate maximum temperature.

^C Indicate if preheat maintenance is during welding or until postweld heat treatment is performed.

7.2 Preheat for tack welding of backing plates is the same as required for welding.

7.3 Minimum temperature before applying heat shall be ^A.

^A Indicate temperature.

7.4 Local preheating to the temperatures indicated may be performed so that the heated area completely surrounds the weld preparation for a minimum distance of ^A in any direction.

^A Indicate minimum distance for local preheating.

8. Welding Position

8.1 Welds shall be made in the ^A position.

^A Indicate position or positions in which the welding will be performed. See Fig. 4.

9. Electrical Characteristics

9.1 The current used shall be ^A. The base material shall be attached to the ^B welding electrode lead.

^A Indicate whether direct or alternating current. If direct, state whether non-pulsed or pulsed. If pulsed, state frequency.

^B Indicate whether electrode positive (EP) or electrode negative (EN) output terminal of power supply is used.

Electrode

Wire

Diameter^A

Amperage^A

Range^A

Voltage^A

^A Indicate for each diameter of electrode, the amperage, the range of amperage permitted, and the voltage requirements. For welding processes using wire, indicate wire diameter, wire feed speed, and current requirements.

9.2 Electrodes subject to moisture absorption must be stored and handled to maintain dryness according to the following: ^A.

^A Where applicable, indicate electrode care instructions.

10. Welding Details

10.1 The width of any pass of welding shall not exceed ^A times the size of the filler metal used.

^A Indicate the number for controlling the maximum width.

10.2 Craters shall be properly filled before each interruption of the arc.

10.3 Slag or flux shall be removed on any bead before depositing the next successive bead.

10.4 Interpass inspection shall be performed according to the following: ^A.

^A Indicate degree of interpass inspection required.

10.5 Peening shall be performed according to the following: ^A.

^A Indicate the degree of peening required. Indicate any limits on peening first and last layers.

11. Post-Weld Heat Treatment

11.1 Post-weld heat treatment shall consist of the following: ^A.

^A Indicate the heating and cooking rates, holding temperatures and times.

12. Inspection

12.1 Inspection of the completed weld shall be performed according to the following: ^A.

^A Indicate degree of inspection.



A488/A488M – 12

FIG. 3 Report Form 3

iTeh Standards
(<https://standards.iteh.ai>)
Document Preview

[ASTM A488/A488M-12](#)

<https://standards.iteh.ai/catalog/standards/sist/79b881da-a663-4b90-b443-a99d671a556c/astm-a488-a488m-12>



4. Weld Orientation

4.1 *Orientation*—The orientation of welds with respect to horizontal and vertical planes of reference are classified into four positions, namely, flat, horizontal, vertical, and overhead as shown in Fig. 4. Test material shall be oriented as shown in Fig. 4; however, an angular deviation of $\pm 15^\circ$ from the specified horizontal and vertical planes is permitted during welding.

4.2 *Flat Position* (Fig. 4(a))—This position covers plate in a horizontal plane with the weld metal deposited from above, or pipe or a cylindrical casting with its axis horizontal and rolled during welding so that the weld metal is deposited from above.

4.3 *Horizontal Position* (Fig. 4(b))—This position covers plate in a vertical plane with the axis of the weld horizontal, or pipe or a cylindrical casting with its axis vertical and the axis of the weld horizontal.

4.4 *Vertical Position* (Fig. 4(c))—In this position, the plate is in a vertical plane with the axis of the weld vertical.

4.5 *Overhead Position* (Fig. 4(d))—In this position, the plate is in a horizontal plane with the weld metal deposited from underneath.

4.6 *Horizontal Fixed Position* (Fig. 4(e))—In this position, the pipe or cylindrical casting has its axis horizontal and the welding groove in a vertical plane. Welding shall be done without rotating the pipe or casting so that the weld metal is deposited from the flat, vertical, and overhead position.

4.7 *Qualification*—Qualification in the horizontal, vertical, or overhead position shall qualify also for the flat position. Qualification in the horizontal fixed position, or in the horizontal and vertical and overhead positions, shall qualify for all positions.

5. Preparation of Test Plate

5.1 Procedure qualification testing shall be performed on cast or wrought material having the same category number as the casting being welded. Test material shall be subjected to the same heat treatment before and after welding as will be applied to the casting. If the castings are not to be postweld heat treated, then the test material is not to be postweld heat treated. Test plate material for performance qualification testing is covered in 12.2.

5.2 The dimensions of the test plate shall be such as to provide the required number of test specimens.

5.3 The test joint shall be welded using the type of welding groove proposed in the welding procedure. The dimensions of the welding groove are not essential variables of the welding procedure.

5.4 The thickness of the test plate shall depend on the range of thickness to be qualified as shown in Table 2 and Table 3.

5.5 The joint preparation shown in Fig. 5 shall qualify the supplier for all welding on steel castings.

5.6 Where pipe or a cylindrical casting is used for qualification, it is recommended that a minimum nominal diameter of 5 in. [125 mm] and a minimum thickness of $\frac{3}{8}$ in. [10 mm] be used.

6. Types of Tests

6.1 Four types of tests are used in the qualification procedure as follows:

6.1.1 *Tension Test*—Tests in direct tension are used in the procedure qualification to measure the strength of groove-weld joints.

6.1.2 *Bend Test*—Guided bend tests are used in the procedure and performance qualification tests to check the degree of soundness and ductility of groove-weld joints.

6.1.3 *Charpy Impact Test*—Charpy V-notch impact test specimens are used in the procedure qualification to determine the impact strength of weld metal deposited in groove-type joints.

6.1.4 *Radiographic Test*—Radiographic examination in accordance with 12.6 of a length of weld may be used to prove the ability of operators and welders to make sound welds.

7. Tension Test

7.1 *Specimens*—Tension tests shall be in accordance with the requirements of 7.1.1 or 7.1.2.

7.1.1 All thicknesses of plate may be tested using reduced-section specimens in accordance with the requirements of Fig. 6. All thicknesses of pipe or cylindrical castings having an outside diameter greater than 3 in. [75 mm] may be tested using reduced-section specimens in accordance with the requirements of Fig. 7.

7.1.1.1 A single specimen of full-plate or full-pipe thickness shall be used for thicknesses up to and including 1 in. [25 mm].

7.1.1.2 For plate or pipe thicknesses greater than 1 in. [25 mm], single or multiple specimens may be used.

7.1.1.3 When multiple specimens are used, each set shall represent a single required tension test. Collectively, all of the specimens required to represent the full thickness of the weld at one location shall comprise a set.

7.1.1.4 When multiple specimens are necessary, the entire thickness shall be mechanically cut into a minimum number of approximately equal strips of a size that can be tested in the available equipment. Each specimen shall be tested and meet the requirements of 7.1.4.

7.1.2 Turned specimens in accordance with the requirements of Fig. 8 may be used for tension tests.

7.1.2.1 For thicknesses up to and including 1 in. [25 mm], a single-turned specimen may be used, which shall be a specimen of the largest diameter possible for the test coupon thickness.

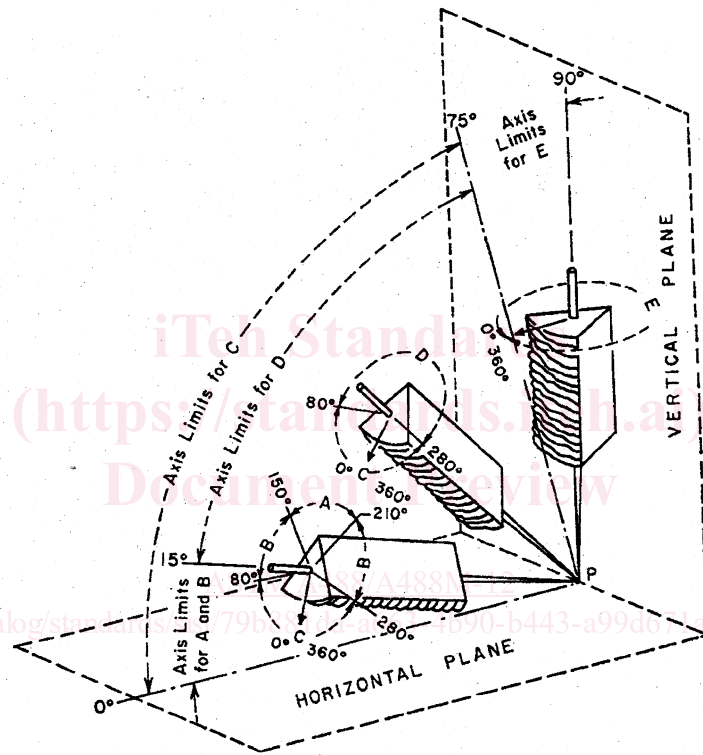
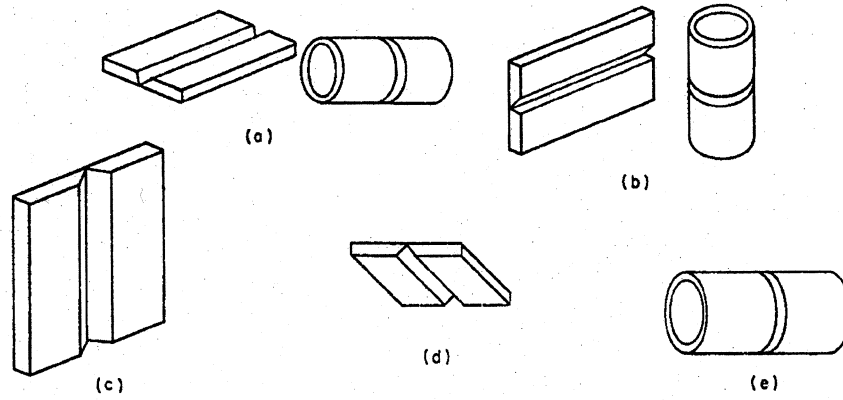

Tabulation of Positions of Groove Welds

Position	Diagram Reference	Inclination of Axis, °	Rotation of Face, °
Flat	A	0 to 15	150 to 210
Horizontal	B	0 to 15	80 to 150 210 to 280
Overhead	C	0 to 80	0 to 80 280 to 360
Vertical	D	15 to 80	80 to 280
	E	80 to 90	0 to 360

NOTE 1—(a) Flat Position; (b) Horizontal Position; (c) Vertical Position; (d) Overhead Position; (e) Horizontal Fixed Position

FIG. 4 Orientation of Welds

TABLE 2 Type and Number of Test Specimens and Range of Thicknesses Qualified—(Procedure)

Thickness, <i>t</i> , of Test Plate or Pipe as Welded, in. [mm]	Range of Thicknesses Qualified ^A		Type and Number of Tests Required ^B			
	min, in. [mm]	max	Reduced Section Tension	Side Bend	Face Bend	Root Bend
1/16 to 3/8 [1.6 to 9.5], incl	1/16 [1.6]	2 ^C <i>t</i>	2	...	2	2
Over 3/8 [9.5], under 3/4 [19.0]	3/16 [4.8]	2 ^C <i>t</i>	2	...	2	2
3/4 [19.0] to under 1 1/2 [38.1]	3/16 [4.8]	2 ^C <i>t</i>	2	4
1 1/2 [38.1] and over	3/16 [4.8]	8 [203]	2	4

^A For repair welding, the minimum thickness requirements do not apply.

^B Either the face- and root-bend tests or the side-bend tests may be used for thicknesses from 3/8 to 3/4 in. [9.5 to 19.0 mm].

^C The maximum thickness qualified with pipe smaller than 5 in. [127 mm] is two times the thickness of the pipe but not more than 3/4 in. [19.0 mm].

TABLE 3 Type and Number of Test Specimens and Thickness Limits Qualified—(Performance)

Thickness, <i>t</i> , of Test Plate or Pipe as Welded, in. [mm]	Thickness Qualified	Type and Number of Tests Required ^A		
		Side Bend	Face Bend	Root Bend
Up to 3/8 [9.5], incl	2 ^C <i>t</i>	...	1	1
Over 3/8 [9.5], under 3/4 [19.0] ^B	2 ^C <i>t</i>	...	1	1
Over 3/8 [9.5], under 3/4 [19.0] ^B	2 ^C <i>t</i>	2
3/4 [19.0], and over	max to be welded	2

^A A total of four specimens are required to qualify for Position 1(e) of Fig. 4. Refer to Fig. 17 and Fig. 18.

^B Either the face- and root-bend tests or the side-bend tests may be used for thicknesses from 3/8 to 3/4 in. [9.5 to 19.0 mm].



FIG. 5 Joint Preparation

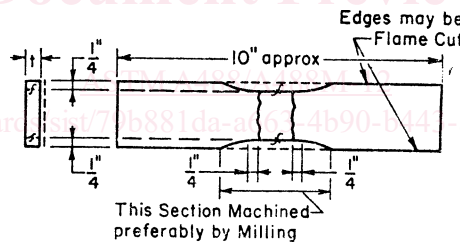

Metric Equivalents

in.	1/4	10
[mm]	[6]	[255]

FIG. 6 Reduced-Section Tension Specimen for Plate

7.1.2.2 For thicknesses greater than 1 in. [25 mm], multiple specimens shall be cut through the full thickness of the weld with their centers parallel to the metal surface and not over 1 in. [25 mm] apart. The centers of the specimens adjacent to the metal surfaces shall not exceed 5/8 in. [16 mm] from the surface.

7.1.2.3 When multiple specimens are used, each set shall represent a single required tension test. Collectively, all of the specimens required to represent the full thickness of the weld at one location shall comprise a set. Each specimen shall be tested and meet the requirements of 7.1.4.

7.1.3 The weld shall be in the center of the reduced section.

7.1.4 In order to meet the requirements of the tension test, specimens shall have a tensile strength not less than the specified tensile strength of the base metal. If the specimen breaks in the base metal outside of the weld or fusion line, the test shall be accepted as meeting the requirements, provided the strength is not more than 5 % below the specified minimum tensile strength of the base metal.

7.2 *Tension Test*—Tension tests shall be conducted in accordance with Test Methods and Definitions A370.