



Designation: ~~D409/D409M – 11a~~^{ε1} D409/D409M – 12

Standard Test Method for Grindability of Coal by the Hardgrove-Machine Method¹

This standard is issued under the fixed designation D409/D409M; the number immediately following the designation indicates the year of original adoption or, in the case of revision, the year of last revision. A number in parentheses indicates the year of last reappraisal. A superscript epsilon (ε) indicates an editorial change since the last revision or reappraisal.

This standard has been approved for use by agencies of the Department of Defense.

¹ NOTE—~~Figure 1 was editorially corrected and footnote 5 was editorially added in February 2012.~~

INTRODUCTION

This test method is structured into the following parts:

The body of the test method discusses the scope, referenced documents, significance and use, apparatus, gross samples, preparation of test samples, procedure, calculation and report, precision and bias, and keywords.

Annex A1 contains the method to obtain and prepare coal feedstock for potential use as HGI RMs (reference materials).

Annex A2 contains the method to divide and containerize the candidate HGI RMs (candidate HGI RMs) from the feedstock prepared in **Annex A1**.

Annex A3 contains the method for homogeneity testing of the candidate HGI RMs containerized in **Annex A2**.

Annex A4 contains the method for determining the Hardgrove grindability index (HGI) to be assigned to each lot of the candidate HGI RMs.

Annex A5 contains the method used to calibrate a Hardgrove grindability machine using the primary or secondary HGI RMs.

Annex A6 contains the method for determining the moisture content of the 1.18 × 0.60 mm (No. 16 × 30) test sample.

1. Scope

1.1 This test method² covers the determination of the relative grindability or ease of pulverization of coals in comparison with coals chosen as standards. A prepared and sized sample receives a definite amount of grinding energy in a miniature pulverizer, and the size consist of the pulverized product is determined by sieving. The resultant size consist is used to produce an index relative to the ease of grinding [Hardgrove Grindability Index (HGI)].

1.1.1 Some coals, such as some high-volatile bituminous, subbituminous, and lignite coals, can undergo physical change as the natural or seam moisture is released during handling and preparation. This change is often sufficient to alter the grindability characteristics that will be reported when tested in the laboratory and could produce different indices dependent on the conditions of drying and the moisture level of the 1.18 × 0.60 mm (No. 16 × 30) (see Test Method **D4749**) materials used for the test. Therefore, the repeatability and reproducibility cited in this test method may not apply for these high-volatile bituminous, subbituminous, and lignite coals.

1.2 The values stated in either SI units or inch-pound units are to be regarded separately as standard. The values stated in each system may not be exact equivalents; therefore, each system shall be used independently of the other. Combining values from the two systems may result in non-conformance with the standard.

¹ This test method is under the jurisdiction of ASTM Committee **D05** on Coal and Coke and is the direct responsibility of **D05.07** on Physical Characteristics of Coal. Current edition approved Dec. 1, 2011/Oct. 1, 2012. Published January 2012/December 2012. Originally approved in 1951. Last previous edition approved in 2011 as **D409 – 11: D409 – 11a**¹. DOI: 10.1520/D0409_D0409M-11A-10.1520/D0409_D0409M-12.

² For information concerning the experimental work on which this test method is based, see paper by Hardgrove, R. M., "Grindability of Coal," *Transactions*, American Society of Mechanical Engineers, Vol 54, F.S.P., p. 37, 1932.

D05.07 on Physical Characteristics on Coal is conducting ongoing investigations in regard to quality control during preparation, distribution, and use of standard reference materials and during preparation and testing of actual samples.

1.3 This standard does not purport to address all of the safety concerns, if any, associated with its use. It is the responsibility of the user of this standard to establish appropriate safety and health practices and determine the applicability of regulatory limitations prior to use.

2. Referenced Documents

2.1 ASTM Standards:³

- [D2013 Practice for Preparing Coal Samples for Analysis](#)
- [D2234/D2234M Practice for Collection of a Gross Sample of Coal](#)
- [D3302 Test Method for Total Moisture in Coal](#)
- [D4749 Test Method for Performing the Sieve Analysis of Coal and Designating Coal Size](#)
- [D6708 Practice for Statistical Assessment and Improvement of Expected Agreement Between Two Test Methods that Purport to Measure the Same Property of a Material](#)
- [D6883 Practice for Manual Sampling of Stationary Coal from Railroad Cars, Barges, Trucks, or Stockpiles](#)
- [D7430 Practice for Mechanical Sampling of Coal](#)
- [E11 Specification for Woven Wire Test Sieve Cloth and Test Sieves](#)

3. Significance and Use

3.1 This test method develops a measurement of grinding or pulverizing characteristics that can be used to evaluate the yield, or energy input, or both, required in a grinding or pulverizing process, which can impact a wide variety of processes, including combustion, coke-making, liquefaction, and gasification.

4. Apparatus

4.1 *Air-Drying Oven [for air-drying the 1000 g, 4.75 mm (No. 4) sample]*—A device for passing slightly heated air over the sample. The oven shall be capable of maintaining a temperature of 10 to 15 °C [18 to 27 °F] above room temperature with a maximum oven temperature of 40 °C [104 °F] unless ambient temperature is above 40 °C, in which case ambient temperature shall be used. In the case of easily oxidized coals, the temperature shall not be over 10 °C [18 °F] above room temperature unless ambient temperature is above 37 °C [100 °F] in which case ambient temperature shall be used. Air changes shall be at the rate of 1 to 4 air volumes of oven capacity per minute.

4.2 *Drying Pans [for air-drying the 1000 g, 4.75 mm (No. 4) sample]*—Drying pans of sufficient size so that the sample may be spread to a depth of not more than 25 mm [1.0 in.] with sides not more than 38 mm [1.5 in.] high. The pans shall be nonreactive with coal and unaffected by the method of air drying selected.

4.3 *Balance [for weighing the 1000-g sample before and after air-drying and the sieve fractions formed during stage-crushing]*—With a sensitivity of at least 0.5 g in 1000 g and sufficient capacity to weigh a sample with a mass of greater than or equal to 1000g along with the drying pan.

4.4 *Balance [for weighing the 50-g test sample and the sieve fractions formed during milling]*—With a sensitivity of at least 10 mg and a minimum capacity of 800 g.

NOTE 1—A single balance meeting the specifications of 4.3 and 4.4 is permitted.

4.5 *Calibration Weights*—These calibration weights shall be used periodically to monitor the response of each balance over the working range.

4.6 *Sample Divider*—An enclosed riffle divider with feed chute as described in Practice [D2013](#) or a rotary sample divider, which has been proven to be free of significant bias, may be used.

4.7 *Standard Sieves*—A working set of circular, standard testing sieves, which are 203 mm [8 in.] in diameter and conform to Specification [E11](#), are required in the following sizes, together with cover and catch pan (receiver):

TABLE 1 Standard Sieves for HGI Testing

E11 Specification	U.S.A. Standard Sieve Series Designation
16.0 mm	¾ in.
4.75 mm	No. 4
2.36 mm	No. 8
1.18 mm	No. 16
600 µm	No. 30
75 µm	No. 200

4.7.1 These working sieves must be periodically inspected for wear or damage. Any excessively worn or damaged sieves (for example, sieves with holes, tears, cracks; etc.) must be replaced immediately, and the HGI calibration procedure must be repeated

³ For referenced ASTM standards, visit the ASTM website, www.astm.org, or contact ASTM Customer Service at service@astm.org. For *Annual Book of ASTM Standards* volume information, refer to the standard's Document Summary page on the ASTM website.

after the damaged sieves are replaced (see [Annex A5](#)). Since the HGI depends upon the sieve analysis and since the 75- μm (No. 200) sieve is fragile, it is recommended that at least one set of working sieves be obtained, identified, and used exclusively for HGI determinations and that only this exclusive set of sieves be used for determining HGI.

4.7.1.1 Excessive wear may be indicated by poor repeatability or by failure of quality control checks ([A5.4.1.1](#)) to agree reasonably with the initial calibration data.

4.7.2 Normal wear on sieves is compensated by the use of primary HGI standard reference samples (HGI RMs) and proper calibration of equipment; excessive wear (such as holes or tears in the sieve cloth, and so forth) is not compensated by HGI RMs. Because excessive wear is unacceptable, inspect sieves carefully before each test to ensure the absence of excessive wear. For the 75- and 600- μm (No. 200 and 30) sieves, use only a soft-bristled brush (such as short-bristled camel hair) for brushing and cleaning.

4.7.2.1 It is good practice to keep a separate primary 75- μm (No. 200) check sieve to be used only to check the 75- μm (No. 200) working sieves described in [4.7.1](#) whenever the working sieve becomes suspect. This check is done by running a comparative HGI test between the two 75- μm (No. 200) sieves. Use of the working sieve for HGIs should be discontinued if HGI difference between the sieves is greater than 1 HGI unit.

4.8 *Plate Mill Crusher*—A laboratory plate mill capable of reducing 4.75-mm (No. 4) sieve size coal particles with the production of a minimum of minus 0.60-mm (minus No. 30) sieve size material. The crusher plates shall be serrated and about 100 mm [4 in.] in diameter. The distance between the plates shall be adjustable, and the relative speed of rotation of the plates shall not exceed 200 r/min.

4.8.1 Evidence from HGI standard reference sample user-response forms ([A5.4.4](#)) indicates that the median value of % Yield ([8.3](#)) of the 4.75-mm (No. 4) material as 1.18 \times 0.60 mm (No. 16 \times 30) material, regardless of the HGI level, is about 55 %. Use this median value to gage the effectiveness/efficiency of the stage-crusher and of the stage-crushing process, while noting that, in some situations, the % Yield has been as low as 45%.

4.8.2 The most frequently used plate mill can be equipped with “fine” or “coarse” plates. One independent study⁴ has found evidence of differences in percent recovery resulting from use of different types of plate. In order to obtain the maximum % Yield, only the coarse plate should be used in preparation of both HGI calibration standards and unknown samples.

4.9 *Mechanical Sieving Machine*—The mechanical sieving machine shall accept an assembly of vertically nested circular sieves of 203 mm [8 in.] in diameter, together with cover and receiver. The machine shall simulate the motions given testing sieves during hand sieving by imparting a horizontal oscillatory motion of approximately 28-mm [1.1-in.] amplitude at a rate of approximately 300 oscillations or cycles per minute (cpm). Simultaneously, the top of the oscillating assembly is struck at a rate of approximately 150 blows per minute by a mass of 1.9 kg [4.2 lb] moving through a vertical distance of approximately 28 mm [1.1 in.] under the influence of gravity.

4.9.1 Whenever a mechanical sieving machine other than the reference machine described above is used, the method may be shown to be equivalent by one of two methods (1) side x side equivalency testing of the alternative machine vs. the reference machine (with both calibration and test samples that cover the working range), using the equivalency testing statistical technique of [D6708](#) or (2) acceptable performance in an appropriate proficiency test program that covers the working range.

4.10 *Grindability Machine*—The Hardgrove Grindability Machine such as is shown in [Fig. 1](#) is required for this test. Essential tolerances and specifications are shown in [Fig. 2](#). The grindability machine includes a stationary grinding bowl of polished cast iron, with a circular horizontal track that holds eight polished steel balls, each 25.40 \pm 0.13 mm [1.000 \pm 0.005 in.] in diameter. The balls are driven by an upper grinding ring which is rotated at 20 \pm 1 r/min by means of the upper spindle and which, in turn, is driven by an electric motor through reduction gears or, in newer models, belts. Weights are added to the driving spindle so that the total vertical force on the balls as a result of the weights, shaft, top grinding ring, and gear is equal to 29.0 \pm 0.2 kg [64 \pm 0.5 lb]. The machine is equipped with a counter and automatic device, which can be properly adjusted for stopping the machine after 60 \pm 0.25 revolutions.

4.10.1 It is good laboratory practice to have the dimensions and the tolerances components that are subject to wear verified on a periodic basis.

4.10.2 The position of the counter trip mechanism before and after the test must be used to determine the number of revolutions completed. With some machines, it may be necessary to position strategically the counter trip mechanism at the beginning of the test to accomplish the desired number of revolutions (that is, during a set-up period, watch where the trip mechanism is initially, count the number of revolutions from the point of origin, determine where the trip mechanism is at the end of the test, and determine if the specified 60 \pm 0.25 revolutions are obtained. If not, adjust the position of the trip mechanism at the beginning of the test until the specified number of revolutions are obtained). Periodically, verify that the machine is operated to obtain the specified number of revolutions per test.

5. Gross Samples

5.1 Collect a gross sample of coal, representative of the material from which it is taken. The sample may be collected, in accordance with Practice [D2234/D2234M](#), [D6883](#), or [D7430](#) (or equivalent other international or national standard), and prepared

⁴ D05.07 Minutes, J. Gardner, Georgia Power and G. Linton, October 1990.



FIG. 1 Hardgrove Grindability Machine

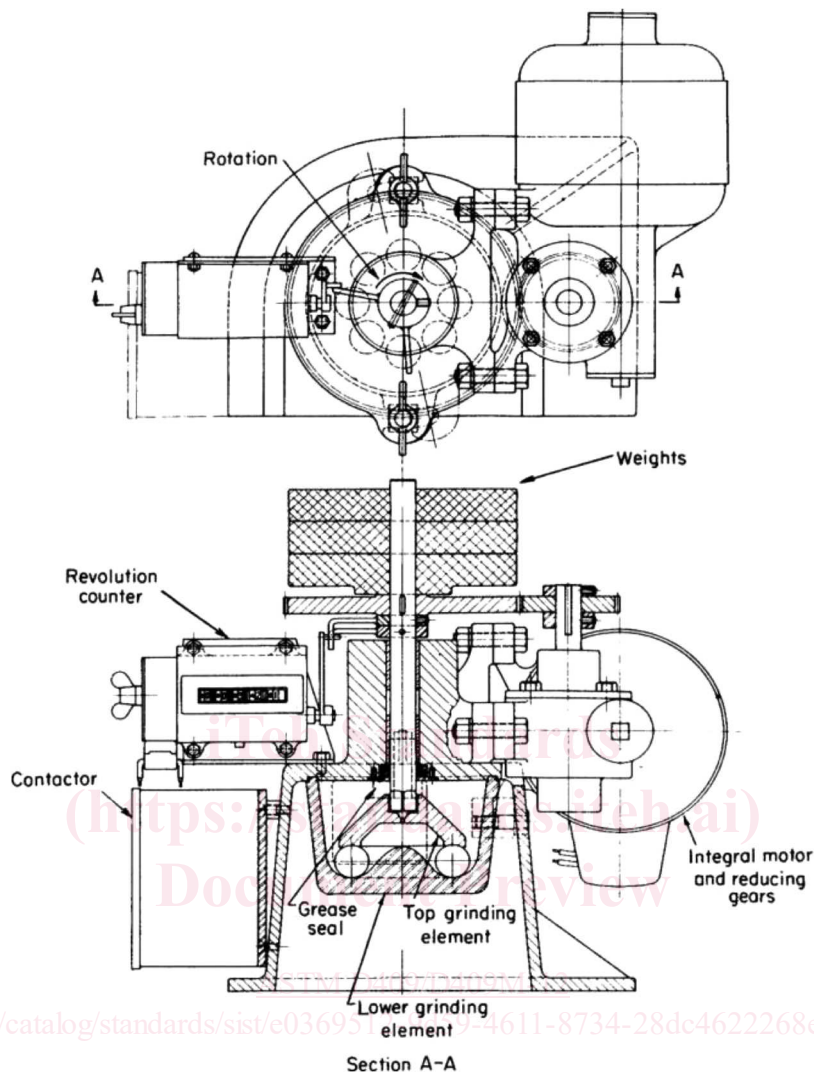

Item	Mass, kg	Mass, lb
Lead	25.9	57.0
Shaft and Gear	2.0 [†]	4.5
Top Ring	1.1	2.5
Total	29.0 ± 0.2	64.0 ± 0.5

[†] Editorially corrected in February 2012.

in accordance with Practice **D2013** (or equivalent other international or national standard) except that the sample tosize shall not be reduced beyond the 4.75-mm (No. 4) sieve and the sample shall have a mass of at least 1000 g.

5.2 If the tosize of the final sample product produced from mechanical sampling system is smaller than 4.75mm (No. 4), the sample does not meet the requirements of this test procedure.

6. Preparation of Test Samples

6.1 Prepare a 1.18 × 0.60 mm (No. 16 × 30) test sample for establishing the HGI of HGI RMs (**Annex A4**), for calibration (**Annex A5**), or for routine determination of HGI.

6.2 When necessary, divide the quantity of 4.75-mm (No. 4) sieve size coal to not less than 1000-g lots using an enclosed riffle or rotary sample divider, and air dry each sample in conformance with Test Method **D3302**. To calculate the % Yield (8.3), record the mass of the air-dried sample (m_1).

6.3 Sieve the entire amount (1000 g) of air-dried 4.75-mm (No. 4) sieve size sample in lots of no greater than 250 g for 2 min 6 10 s in the mechanical sieving machine. Use a set of nested sieves consisting of a 1.18-mm (No. 16) sieve on top of a 0.60-mm (No. 30) sieve. Weigh and record the mass of each sieve size.

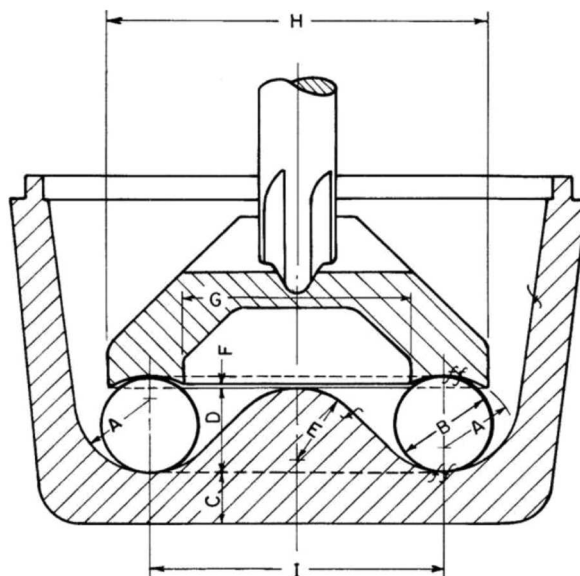

6.3.1 Include a 4.75-mm (No. 4) and a 2.36-mm (No. 8) sieve in this nest of sieves to ease separation, determine and record the “natural” particle size distribution, and to verify that the topsize of the sample is appropriate for this test. Sieving more than 250 g at a time on the 200-mm [8-in.] diameter sieve may not allow each particle to “see” the sieve surface and have an opportunity to pass or to be retained by the sieve.

6.4 Combine and stage crush all of the sieve fractions greater than the 1.18-mm (No. 16) sieve with the crusher adjusted so that only the largest particles are crushed. Sieve the crushed material in portions of no greater than 250 g for 2 min \pm 10 s in the mechanical sieving machine. Return the oversize to the crusher, after setting the crusher so that only the largest particles are crushed. Continue the stage crushing and sieving procedure until all the material passes the 1.18-mm sieve. Retain the 1.18 \times 0.60 mm (No. 16 \times 30) material. After all stage-crushing is completed, to calculate the % Yield (8.3), record the mass of the 1.18 \times 0.60 mm (No. 16 \times 30) fraction (m_2).

6.5 Mix well all the 1.18 \times 0.60 mm (No. 16 \times 30) material accumulated from the stage crushing and sieving process and divide the quantity using an enclosed riffle or rotary sample divider to obtain approximately 120 \pm 10 g.

6.6 As the final step in preparation of the test sample, dedust the 120 \pm 10-g sample from 6.5 by sieving on a 0.60 mm (No. 30) sieve for 5 min \pm 10 s using the mechanical sieving machine.

6.6.1 Determining the mass of each sieve fraction after each stage-crushing step will allow the rate of reduction to be calculated and evaluated as a contributor to achieving adequate % Yield.

7. Procedure

7.1 Clean the grindability machine thoroughly, place the machine on a level surface, and space the balls as evenly as possible around the grinding bowl. Set the automatic stopping device so that the motion of the grindability machine will stop after 60 \pm 0.25 revolutions of the upper grinding ring.

7.1.1 If the grindability machine makes a different number of revolutions other than the specified 60 \pm 0.25 revolutions, the machine must be adjusted to within the tolerance specified. (This is normally done by strategically placing the counter tripper arm at the start of the test. See 4.10.2.)

7.2 Weigh 50 \pm 0.01 g of the 1.18 \times 0.60 mm (No. 16 \times 30) sieve size dedusted material from 6.6 and distribute it evenly in the grinding bowl, brushing any material that falls on the elevated section of the lower grinding element into the lower grinding element, which contains the balls. Fasten the bowl in position and make sure the load is fully applied to the driving spindle.

7.3 Operate the machine for the specified 60.00 \pm 0.25 revolutions.

7.4 Remove the bowl from the machine, lift out the upper grinding ring, and carefully brush adhering coal dust from the bowl and grinding ring onto a 16-mm [$\frac{5}{8}$ -in.] sieve nested on a 75- μ m (No. 200) sieve and a closely fitting receiving pan. Carefully empty the contents of the bowl onto the 16-mm [$\frac{5}{8}$ -in.] sieve. Brush off material adhering to the balls and remove the balls from the 16-mm [$\frac{5}{8}$ -in.] sieve. Brush material adhering to the 16-mm [$\frac{5}{8}$ -in.] sieve, including the underside of the sieve, onto the 75- μ m (No. 200) sieve. Replace the 16-mm [$\frac{5}{8}$ -in.] sieve with a close-fitting cover and shake the nested 75- μ m (No. 200) sieve; cover and pan for 10 min \pm 10 s in a mechanical sieving machine. After the 10-min \pm 10-s period, carefully brush coal dust from the



- A = 19.05 ± 0.13 mm [0.750 ± 0.0005 in.] radius
 B = 25.40 ± 0.13 mm [1.000 ± 0.0005 in.] diameter
 C = 12.70 mm [0.50 in.]
 D = 22.23 mm [0.875 in.]
 E = 19.05 mm [0.750 in.]
 F = 1.42 mm [0.078 in.]
 G = 60.33 mm [2.375 in.]
 H = 98.43 mm [3.875 in.]
 I = 76.20 mm [3.000 in.]
 f = smooth machine surface
 ff = fine machined surface and polished

underside of the 75-µm (No. 200) sieve into the receiving pan using a soft-bristled brush to avoid damaging the sieve. Repeat the shaking of the ball-milled material and the cleaning of the underside of the 75-µm (No. 200) sieve for two more periods each of 5-min ± 10-s duration.

7.4.1 Before emptying the contents of the lower grinding bowl onto the 16-mm [$\frac{5}{8}$ -in.] sieve, the tops of the grinding balls may be brushed and then the balls may be removed from the lower grinding bowl by use of a magnetic extraction tool. Each grinding ball is brushed off and set aside; then, the pulverized coal is emptied from the bowl onto the 16-mm [$\frac{5}{8}$ -in.] sieve.

7.5 Weigh separately to the nearest 0.01 g the coal retained on the 75-µm (No. 200) sieve (m_3) and the coal passing the 75-µm (No. 200) sieve (m_4).

7.5.1 Alternatively, predetermine the tare masses of the 75-µm (No. 200) sieve (m_5) and the catch pan (m_6). After the sieving of 7.4, weigh the 75-µm (No. 200) sieve and its contents (m_7). Subtract the tare mass to obtain the mass of the +75-µm (+No. 200) material = $m_3 = m_7 - m_5$. Weigh the catch pan and its contents (m_8). Subtract the tare mass to obtain the mass of the -75-µm (-No. 200) material = $m_4 = m_8 - m_6$.

7.6 If the sum of the +75-µm (+No. 200) (m_3) and the -75-µm (-No. 200) (m_4) sieve fraction masses differs by more than 0.50 g from the initial mass of 50 ± 0.01 g (m_9 , see 7.2), reject the test and repeat. Use the calculated mass of the coal passing the 75-µm (No. 200) sieve (m_{10}), determined by subtracting the mass retained on the 75-µm (No. 200) sieve (m_3) from the test specimen mass (m_9), in determining the sum-of-least-squares fit (A5.4.3), in preparation of the calibration chart (A5.4.3.2) or in calculation of the grindability index of the sample (8.1) $m_{10} = m_9 - m_3$.

8. Calculation and Report

8.1 Calculate the grindability index corresponding to the calculated mass of test specimen passing the 75-µm (No. 200) sieve (7.5) directly from the equation of the line prepared in A5.4.3 and report to the nearest whole number.

8.2 For ease of comparison between or among laboratories, calculate and report the percent residual moisture in the 1.18 × 0.60 mm (No. 16 × 30) sample (Annex A6).

8.3 Calculate the % Yield of 1.18 × 0.60 mm (No. 16 × 30) material generated from the initial 1000 g of 4.75-mm (No. 4) top-size sample and compare the actual value to a typical median value (4.8.1) to gage the effectiveness/efficiency of the stage-crusher and of the stage-crushing process.

$$Y = \frac{m_2}{m_1} \times 100 \quad (1)$$

where:

- Y = % Yield,
 m_1 = mass of air dried sample (6.2), and
 m_2 = mass of 1.18 × 0.60 mm (No. 16 × 30) material (6.4).

8.4 If other than primary HGI RMs are used for calibration of the test apparatus and method, report the source of the calibration standards used.

8.5 An example of a typical HGI preparation log sheet that has found application for record keeping during preparation of samples to be used for HGI determination is shown in Fig. 3.

9. Precision and Bias⁵

9.1 Precision:

⁵ Supporting data have been filed at ASTM International Headquarters and may be obtained by requesting Research Report RR:D05-1040.



FIG. 2 Grinding Elements of Hardgrove Machine

9.1.1 The precision of this test method for the determination of Hardgrove Grindability Index of Coal, whenever primary HGI reference materials are used for calibration, is shown in [Table 2](#).

9.1.2 For the HGI method, the Repeatability Limit (r) in [Table 2](#) is the value which the absolute difference between two test results of separate and consecutive test determinations, carried out on dedusted 1.18×0.60 mm (No. 16 \times 30) samples in the same laboratory by the same operator using the same apparatus on samples taken at random from a single quantity of homogeneous 4.75 mm (No. 4) material, may be expected to occur with a probability of approximately 95 %.

9.1.3 For the HGI method, the Reproducibility Limit (R) in [Table 2](#) is the value which the absolute difference between two test results, carried out in different laboratories on riffled splits of the 4.75 mm (No. 4) analysis sample, may be expected to occur with a probability of approximately 95 %.

9.1.3.1 The precision of this test method for the determination of Hardgrove Grindability Index of Coal, whenever national (secondary) HGI reference materials are used for calibration, must be determined and reported by each pertinent ISO national member body (NMB) and/or their national organization responsible for obtaining and preparing national (secondary) HGI RMs. The precision limits for this test method, whenever these national (secondary) RMs are used, will be as large or larger than the precision limits stated in [Table 2](#).

9.2 *Bias*—Since this test method (using a calibration procedure) is an empirical standard, the degree of absolute bias cannot be determined.

10. Keywords

10.1 grindability; Hardgrove Grindability Index; HGI; pulverization

iTeh Standards
(<https://standards.iteh.ai>)
Document Preview

[ASTM D409/D409M-12](#)

<https://standards.iteh.ai/catalog/standards/sist/e0369512-9d59-4611-8734-28dc4622268e/astm-d409-d409m-12>



Sample I.D.: _____		Date: _____		Analyst: _____	
Sample Description: _____					
AIR-DRYING					
Air-dry pan mass, (a): _____ g		Ambient Temp: _____ °C [°F]			
Initial sample and air-dry pan mass, (b): _____ g		Time into oven: _____			
Final sample and air-dry pan mass, (c): _____ g		Time out of oven: _____			
Air-dried sample mass, c - a, (d): _____ g		Temperature: _____ °C [°F]			
Mass loss on drying, b - c, (e): _____ g		Heat on at: _____			
Initial sample mass, b - a, (f): _____ g		Heat off at: _____			
% Mass loss on drying, e/f x 100%, (g): _____ %		Fan on at: _____			
				Fan off at: _____	
INITIAL SIEVED MASSES					
+4.75 mm (+No.4), (h): _____ g		1.18 x 0.600 mm (No.16 x 30), (k): _____ g			
4.75 x 2.36 mm (No.4 x 8), (i): _____ g		-0.600 mm (-No.30), (l): _____ g			
2.36 x 1.18 mm (No.8 x 16), (j): _____ g		Topsize: _____			
Total recovered mass after sieving, (h + i + j + k + l), (m): _____ g					
Mass loss on sieving, d - m, (n): _____ g					
% Mass loss on sieving, (n/d) x 100%, (o): _____ %					
REDUCTION OF +1.18 mm (+No. 16)					
Mass, +1.18 mm (+No. 16)		Mass, +1.18 mm (+No. 16)			
Initially, h + i + j, (p): _____ g		>6th crushing of oversize, (v): _____ g			
>1st crushing of oversize, (q): _____ g		>7th crushing of oversize, (w): _____ g			
>2nd crushing of oversize, (r): _____ g		>8th crushing of oversize, (x): _____ g			
>3rd crushing of oversize, (s): _____ g		>9th crushing of oversize, (y): _____ g			
>4th crushing of oversize, (t): _____ g		>10th crushing of oversize, (z): _____ g			
>5th crushing of oversize, (u): _____ g					
Final total mass of 1.18 x 0.600 mm (No.16 x 30), (A): _____ g					
Final total mass of -0.600 mm (-No.30), (B): _____ g					
Final total recovered mass, (A+B), (C): _____ g					
Loss on crushing, (m-C), (D): _____ g					
% loss on crushing, (D/d) x 100%, (E): _____ %					
% Yield of 1.18 x 0.600 mm (No.16 x 30), A/d x 100%, (F): _____ %					
DEDUSTING 120 g OF 1.18 x 0.60 mm (No.16 x No.30) and Milling					
Mass of 1.18 x 0.60 mm (No.16 x 30) dedusted sample placed into HGI bowl, (G): _____ g		Number of revolutions, (I): _____			
No. of increments collected, (H): _____		Seconds to mill, (J): _____ sec			
Start position: _____		RPM, [(I/J.60)]: _____ RPM			
Stop position: _____					
Start time: _____					
Stop time: _____					
SIEVING OF MILLED PRODUCT					
Tare mass of catch pan, (L): _____ g		Mass of -75 µm (-No.200), (N - L), (P): _____ g			
Tare mass of 75 µm (No.200) sieve, (M): _____ g		Mass of +75 µm (+No.200), (O - M), (Q): _____ g			
Mass of catch pan and -75 µm (-No.200), (N): _____ g		Total recover, (P + Q), (R): _____ g			
Mass of 75µm (No.200) sieve and +75 µm (+No.200), (O): _____ g		Loss (±0.50 g), (G - R), (S): _____ g			
Calculated mass of -75 µm (-No.200), (G - Q), (T): _____ g					
ANALYTICAL RESULTS					
HGI Formula (from Least Squares Regression): _____					
HGI(U): _____					
% moisture on 1.18 x 0.600 mm (No.16 x 30) material: _____ %		See the ANNEX, Method for Determining the Moisture Content of the 1.18x0.600mm (No.16x30) Test Sample			

FIG. 3 HGI Log Sheet is for Example Only and is Non-Mandatory



TABLE 2 Repeatability and Reproducibility for HGI of Coal

Repeatability Limit r	Reproducibility Limit R
3	7

ANNEXES

(Mandatory Information)

**A1. METHOD TO OBTAIN AND PREPARE HGI REFERENCE MATERIAL FEEDSTOCK
(HGI RM Feedstock)**
A1.1 Scope

A1.1.1 This method describes the procedures used to obtain and prepare Hardgrove Grindability Index (HGI) reference material feedstock (HGI RM feedstock).

A1.1.1.1 Recognition to obtain and prepare HGI RM feedstock for use as candidate primary HGI RMs is given by ASTM Committee D05 on Coal and Coke.

A1.1.1.2 Authority to obtain and prepare HGI RM feedstock for use as candidate secondary HGI RMs is given by the pertinent ISO national member body (NMB), which maintains oversight responsibility for these activities.

A1.2 Apparatus

A1.2.1 *Sieves; 4.75 mm (No. 4) and 2.36 mm (No. 8)*—Square mesh sieves meeting the requirements of Test Method D4749, used to verify that the candidate HGI RMs are 4.75-mm (No. 4) topsize.

A1.2.2 *Sieve Shaker*—Meeting the requirements of Test Method D4749, used to verify that the candidate HGI RMs are 4.75-mm (No. 4) topsize.

A1.2.2.1 No specifications are given for the sieve shaker used in the processing of the feedstock; as long as the final product meets the specification of being 4.75-mm (No. 4) topsize, there is no need to specify production equipment.

A1.2.3 *Crusher*—Commensurate with the requirement to maximize the 1.18 × 0.60-mm (No. 16 × 30) size fraction while maintaining a 4.75-mm (No. 4) topsize.

A1.3 HGI RM Feedstock Requirements

A1.3.1 Four coals shall be collected and used as the feedstock for the HGI RMs. One feedstock shall have an HGI of approximately 40 (typically between 35 and 45); a second feedstock shall have an HGI of approximately 60 (typically between 55 and 65); a third feedstock shall have an HGI of approximately 80 (typically between 75 and 85); and a fourth feedstock shall have an HGI of approximately 100 (typically between 90 and 110).

A1.3.2 Each HGI RM feedstock shall have a minimum mass of 80 kg [175 lb]. Where 80 kg [175 lb] is not adequate to produce the desired number of candidate RMs, an adequate mass to produce the desired number of candidate HGI RMs shall be obtained. Each candidate RM sample shall have a minimum mass of 1000 g.

A1.3.3 Any feedstock will be acceptable as long as the final production lot meets the homogeneity requirements found in [Annex A3](#) and [A1.3](#).



A1.3.4 To minimize the potential rejection of a production lot of HGI RMs after the lot has been processed, each feedstock coal should have the following characteristics: (1) be from a single seam, containing no blended materials, (2) be double-sieved to pass a 63-mm [2.5-in.] square-hole sieve while being retained on a 3.35-mm [$\frac{1}{8}$ -in.] square-holed sieve, and (3) be mechanically cleaned, having been through a preparation or wash plant to remove non-coal material.

A1.3.5 Each feedstock coal shall be visually inspected upon its receipt to assure the absence of foreign material. If any foreign material (wood, rock, slate, steel, and so forth) is present, the entire shipment shall be rejected.

A1.3.6 Each feedstock coal shall be visually inspected upon its receipt to assure the absence of more than 5 % of undersized –3.35-mm [$\frac{1}{8}$ in.] or of oversized +63- mm [+2.5 in.] particles. If undersized –3.35-mm [$\frac{1}{8}$ in.] or oversized +63-mm [+2.5 in.] material constitutes greater than 5 % of the lot, after air-drying, the entire shipment shall be sieved to remove the undersize or oversize prior to further processing.

A1.4 Preparation of Each Candidate HGI RM

A1.4.1 Each feedstock is prepared according to the instructions in this section.

A1.4.2 Spread the feedstock coal (onto a smooth, flat, non-contaminating surface) to a thickness of no more than three times the particle tosize. A floor fan and periodic stirring can accelerate drying. Air dry the feedstock at room temperature for at least 12 h.

A1.4.2.1 If, after air drying, a feedstock contains greater than 5 % undersize (–3.35-mm) [$\frac{1}{8}$ in.] or greater than 5 % oversize +63-mm [+2.5 in.], sieve the entire feedstock coal to remove the undersize or oversize.

A1.4.3 Reduce the air-dried feedstock to 4.75-mm (No. 4) top size. Use a crusher and a technique that will maximize the 1.18 × 0.60 mm (No. 16 × 30) size fraction while maintaining a 4.75-mm (No. 4) topsize.

A1.4.3.1 Verify that each reduced feedstock is a 4.75-mm (No. 4) topsize by obtaining a sample from each feedstock and conducting a size analysis [at 4.75 and 2.36 mm (No. 4 and 8)] according to the requirements of Test Method **D4749**. No more than 5 % of the sample may be retained on a 4.75-mm (No. 4) sieve and no less than 5 % of the sample may be retained on a 2.36-mm (No. 8) sieve (cumulative retained basis).

A1.4.4 Dedust each feedstock by removing and discarding the –0.30-mm (–No. 50) material.

A1.4.5 If the feedstock is to be transported or held for subsequent processing, package the material in a rigid, non-contaminating container. If necessary, line the container with double plastic liners to preserve the feedstock integrity and avoid excessive handling.

A2. METHOD TO DIVIDE AND CONTAINERIZE CANDIDATE HGI REFERENCE MATERIALS (Candidate HGI RMs)

A2.1 Scope

A2.1.1 This method describes the procedures used to divide and containerize candidate Hardgrove Grindability Index (HGI) reference materials (candidate HGI RMs).

A2.1.2 Recognition to divide and containerize candidate primary HGI RMs for use in determining the HGI of coal (or for calibrating national HGI machines) is given by ASTM Committee D05 on Coal and Coke.