

INTERNATIONAL STANDARD

NORME INTERNATIONALE

Photovoltaic systems – Power conditioners – Procedure for measuring efficiency

Systèmes photovoltaïques – Conditionneurs d'énergie électrique – Procédure de mesure du rendement

IEC 61683:1999

<https://standards.iteh.ai/catalog/standards/sist/27303a7e-a7b7-48fb-a0a9-7e5e5f8a3a7f/iec-61683-1999>



THIS PUBLICATION IS COPYRIGHT PROTECTED
Copyright © 1999 IEC, Geneva, Switzerland

All rights reserved. Unless otherwise specified, no part of this publication may be reproduced or utilized in any form or by any means, electronic or mechanical, including photocopying and microfilm, without permission in writing from either IEC or IEC's member National Committee in the country of the requester. If you have any questions about IEC copyright or have an enquiry about obtaining additional rights to this publication, please contact the address below or your local IEC member National Committee for further information.

Droits de reproduction réservés. Sauf indication contraire, aucune partie de cette publication ne peut être reproduite ni utilisée sous quelque forme que ce soit et par aucun procédé, électronique ou mécanique, y compris la photocopie et les microfilms, sans l'accord écrit de l'IEC ou du Comité national de l'IEC du pays du demandeur. Si vous avez des questions sur le copyright de l'IEC ou si vous désirez obtenir des droits supplémentaires sur cette publication, utilisez les coordonnées ci-après ou contactez le Comité national de l'IEC de votre pays de résidence.

IEC Secretariat
3, rue de Varembe
CH-1211 Geneva 20
Switzerland

Tel.: +41 22 919 02 11
info@iec.ch
www.iec.ch

About the IEC

The International Electrotechnical Commission (IEC) is the leading global organization that prepares and publishes International Standards for all electrical, electronic and related technologies.

About IEC publications

The technical content of IEC publications is kept under constant review by the IEC. Please make sure that you have the latest edition, a corrigendum or an amendment might have been published.

IEC publications search - webstore.iec.ch/advsearchform

The advanced search enables to find IEC publications by a variety of criteria (reference number, text, technical committee, ...). It also gives information on projects, replaced and withdrawn publications.

IEC Products & Services Portal - products.iec.ch

Discover our powerful search engine and read freely all the publications previews. With a subscription you will always have access to up to date content tailored to your needs.

IEC Just Published - webstore.iec.ch/justpublished

Stay up to date on all new IEC publications. Just Published details all new publications released. Available online and once a month by email.

Electropedia - www.electropedia.org

The world's leading online dictionary on electrotechnology, containing more than 22 300 terminological entries in English and French, with equivalent terms in 19 additional languages. Also known as the International Electrotechnical Vocabulary (IEV) online.

IEC Customer Service Centre - webstore.iec.ch/csc

If you wish to give us your feedback on this publication or need further assistance, please contact the Customer Service Centre: sales@iec.ch.

A propos de l'IEC

La Commission Electrotechnique Internationale (IEC) est la première organisation mondiale qui élabore et publie des Normes internationales pour tout ce qui a trait à l'électricité, à l'électronique et aux technologies apparentées.

A propos des publications IEC

Le contenu technique des publications IEC est constamment revu. Veuillez vous assurer que vous possédez l'édition la plus récente, un corrigendum ou amendement peut avoir été publié.

Recherche de publications IEC -

webstore.iec.ch/advsearchform

La recherche avancée permet de trouver des publications IEC en utilisant différents critères (numéro de référence, texte, comité d'études, ...). Elle donne aussi des informations sur les projets et les publications remplacées ou retirées.

Découvrez notre puissant moteur de recherche et consultez gratuitement tous les aperçus des publications. Avec un abonnement, vous aurez toujours accès à un contenu à jour adapté à vos besoins.

IEC Just Published - webstore.iec.ch/justpublished

Restez informé sur les nouvelles publications IEC. Just Published détaille les nouvelles publications parues. Disponible en ligne et une fois par mois par email.

Electropedia - www.electropedia.org

Le premier dictionnaire d'électrotechnologie en ligne au monde, avec plus de 22 300 articles terminologiques en anglais et en français, ainsi que les termes équivalents dans 19 langues additionnelles. Egalement appelé Vocabulaire Electrotechnique International (IEV) en ligne.

Service Clients - webstore.iec.ch/csc

Si vous désirez nous donner des commentaires sur cette publication ou si vous avez des questions contactez-nous: sales@iec.ch.

IEC Products & Services Portal - products.iec.ch

INTERNATIONAL STANDARD

NORME INTERNATIONALE

iTeh STANDARD

Photovoltaic systems – Power conditioners – Procedure for measuring efficiency

PREVIEW

(standards.iteh.ai)

Systemes photovoltaïques – Conditionneurs d'énergie électrique –
Procédure de mesure du rendement

IEC 61683:1999

<https://standards.iteh.ai/catalog/standards/sist/27303a7e-a7b7-48fb-a0a9-7e5e5f8a3a7f/iec-61683-1999>

INTERNATIONAL
ELECTROTECHNICAL
COMMISSION

COMMISSION
ELECTROTECHNIQUE
INTERNATIONALE

ICS 27.160

ISBN 978-2-8322-1092-2

Warning! Make sure that you obtained this publication from an authorized distributor.
Attention! Veuillez vous assurer que vous avez obtenu cette publication via un distributeur agréé.

CONTENTS

FOREWORD.....	3
INTRODUCTION.....	4
1 Scope.....	5
2 Normative reference.....	5
3 Definitions.....	5
4 Efficiency measurement conditions.....	6
4.1 DC power source for testing.....	6
4.2 Temperature.....	6
4.3 Output voltage and frequency.....	6
4.4 Input voltage.....	7
4.5 Ripple and distortion.....	7
4.6 Resistive loads/utility grid.....	7
4.7 Reactive loads.....	7
4.8 Resistive plus non-linear loads.....	8
4.9 Complex loads.....	8
5 Efficiency calculations.....	8
5.1 Rated output efficiency.....	8
5.2 Partial output efficiency.....	8
5.3 Energy efficiency.....	9
5.4 Efficiency tolerances.....	9
6 Efficiency test circuits.....	9
6.1 Test circuits.....	9
6.2 Measurement procedure.....	10
7 Loss measurement.....	10
7.1 No-load loss.....	10
7.2 Standby loss.....	11
Annex A (informative) Power conditioner description.....	12
Annex B (informative) Power efficiency and conversion factor.....	14
Annex C (informative) Weighted-average energy efficiency.....	16
Annex D (informative) Derivation of efficiency tolerance in table 2.....	19
Bibliography.....	20

iTech STANDARD
PREVIEW
(standards.iteh.ai)

IEC 61683:1999

<https://standards.iteh.ai/catalog/standards/sist/27303a7e-a7b7-48fb-a0a9-7e5e5f8a3a7f/iec-61683-1999>

INTERNATIONAL ELECTROTECHNICAL COMMISSION

**PHOTOVOLTAIC SYSTEMS – POWER CONDITIONERS –
PROCEDURE FOR MEASURING EFFICIENCY**

FOREWORD

- 1) The IEC (International Electrotechnical Commission) is a worldwide organization for standardization comprising all national electrotechnical committees (IEC National Committees). The object of the IEC is to promote international co-operation on all questions concerning standardization in the electrical and electronic fields. To this end and in addition to other activities, the IEC publishes International Standards. Their preparation is entrusted to technical committees; any IEC National Committee interested in the subject dealt with may participate in this preparatory work. International, governmental and non-governmental organizations liaising with the IEC also participate in this preparation. The IEC collaborates closely with the International Organization for Standardization (ISO) in accordance with conditions determined by agreement between the two organizations.
- 2) The formal decisions or agreements of the IEC on technical matters express, as nearly as possible, an international consensus of opinion on the relevant subjects since each technical committee has representation from all interested National Committees.
- 3) The documents produced have the form of recommendations for international use and are published in the form of standards, technical specifications, technical reports or guides and they are accepted by the National Committees in that sense.
- 4) In order to promote international unification, IEC National Committees undertake to apply IEC International Standards transparently to the maximum extent possible in their national and regional standards. Any divergence between the IEC Standard and the corresponding national or regional standard shall be clearly indicated in the latter.
- 5) The IEC provides no marking procedure to indicate its approval and cannot be rendered responsible for any equipment declared to be in conformity with one of its standards.
- 6) Attention is drawn to the possibility that some of the elements of this International Standard may be the subject of patent rights. The IEC shall not be held responsible for identifying any or all such patent rights.

International Standard IEC 61683 has been prepared by IEC technical committee 82: Solar photovoltaic energy systems.

The text of this standard is based on the following documents:

FDIS	Report on voting
82/229/FDIS	82/233/RVD

Full information on the voting for the approval of this standard can be found in the report on voting indicated in the above table.

This publication has been drafted in accordance with the ISO/IEC Directives, Part 3.

Annexes A, B, C and D are for information only.

A bilingual version of this standard may be issued at a later date.

The committee has decided that this publication remains valid until 2003. At this date, in accordance with the committee's decision, the publication will be

- reconfirmed;
- withdrawn;
- replaced by a revised edition, or
- amended.

INTRODUCTION

Among the principal characteristics of power conditioners, efficiency is considered as an important factor. A standardized procedure for measuring the efficiency of power conditioners is necessary for their widespread use in photovoltaic systems by increasing the reliability of their claimed efficiency.

Generally speaking, power conditioner efficiency is affected by the following parameters:

- power level;
- input voltage;
- output voltage;
- power factor;
- harmonic content;
- load non-linearity;
- temperature.

These parameters are considered to be included in the test condition of this standard explicitly or implicitly.

The purpose of this standard is to provide the means to evaluate the intrinsic efficiency of power conditioners by a direct measurement of input and output power in the factory. Therefore, indirect items such as maximum power-point tracking accuracy are outside the scope of this document. It is expected that those will be dealt with in future relevant IEC standard(s).

[IEC 61683:1999](https://standards.iteh.ai/catalog/standards/sist/27303a7e-a7b7-48fb-a0a9-7e5e5f8a3a7f/iec-61683-1999)

<https://standards.iteh.ai/catalog/standards/sist/27303a7e-a7b7-48fb-a0a9-7e5e5f8a3a7f/iec-61683-1999>

PHOTOVOLTAIC SYSTEMS – POWER CONDITIONERS – PROCEDURE FOR MEASURING EFFICIENCY

1 Scope

This standard describes guidelines for measuring the efficiency of power conditioners used in stand-alone and utility-interactive photovoltaic systems, where the output of the power conditioner is a stable a.c. voltage of constant frequency or a stable d.c. voltage. The efficiency is calculated from a direct measurement of input and output power in the factory. An isolation transformer is included where it is applicable.

2 Normative reference

The following normative documents contain provisions which, through reference in this text, constitute provisions of this International Standard. For dated references, subsequent amendments to, or revisions of, any of these publications do not apply. However, parties to agreements based on this International Standard are encouraged to investigate the possibility of applying the most recent editions of the normative documents indicated below. For undated references, the latest edition of the normative document referred to applies. Members of IEC and ISO maintain registers of currently valid International Standards.

IEC 60146-1-1:1991, *Semiconductor convertors – General requirements and line commutated convertors – Part 1-1: Specifications of basic requirements*

3 Definitions

For the purposes of this standard, the following definitions apply. All efficiency definitions are applied to electric power conversion alone and do not consider any heat production. The above normative references contain other definitions.

In annex A, the definition of power conditioner is given. Power efficiency and conversion factor are explained in annex B.

3.1

rated output efficiency

ratio of output power to input power when the power conditioner is operating at its rated output

3.2

partial output efficiency

ratio of output power to input power when the power conditioner is operating below its rated output

3.3

energy efficiency

ratio of output energy to input energy during an identified period

3.4

efficiency tolerance

permissible tolerance between the manufacturer's specified efficiency and the measured efficiency

3.5

PV array simulator

simulator which has I-V characteristics equivalent to a PV array

3.6

no-load loss

input power of the power conditioner when its load is disconnected or its output power is zero

3.7

standby loss

for a utility interactive power conditioner, power drawn from the utility grid when the power conditioner is in standby mode. For a stand-alone power conditioner, d.c. input power when the power conditioner is in standby mode

3.8

maximum power point tracking (MPPT)

control strategy whereby the power conditioner input voltage is always at or near the maximum power point of the PV array

4 Efficiency measurement conditions

Efficiency shall be measured under the matrix of conditions as described in the following clauses and table 1. Specific conditions may be excluded by mutual agreement when those conditions are outside the manufacturer's allowable operating range. The resulting data shall be presented in tabular form and may also be presented graphically.

NOTE For example, stand-alone power conditioners are typically designed to handle short-term overload significantly above the rated power. The test at 120 % of rated capacity is included to give an indication of the performance of the power conditioner under these conditions. Some power conditioners are not designed to provide more than their rated output and might be damaged if operated at 120 % of rated capacity. In such cases, test documentation shall note that the test was excluded due to limitation in the power conditioner.

4.1 DC power source for testing

For power conditioners operating with fixed input voltage, the d.c. power source shall be a storage battery or constant voltage power source to maintain the input voltage.

For power conditioners that employ maximum power point tracking (MPPT) and shunt-type power conditioners, either a photovoltaic array or a photovoltaic array simulator shall be utilized.

4.2 Temperature

All measurements are to be made at an ambient temperature of $25\text{ °C} \pm 2\text{ °C}$. Other ambient temperatures may be allowed by mutual agreement. However, the temperature used must be clearly stated in all documentation.

4.3 Output voltage and frequency

The output voltage and frequency shall be maintained at the manufacturer's stated nominal values.

Table 1 – Efficiency recording sheet

Input voltage: _____ (± _____ V)

Total load, % of rated VA		5	10	25	50	75	100	120
Grid-connected	Resistive load	–	()*	()	()	()	()	()
Stand-alone	Resistive load	()	()	()	()	()	()	()
	Reactive load							
	PF = 0,25 or minimum	–	–	()	()	–	()	–
	PF = 0,50 (> minimum)	–	–	()	()	–	()	–
	PF = 0,75 (> minimum)	–	–	()	()	–	()	–
	Non-linear load							
	NL = 25 % of rated VA	–	–	()	()	–	()	–
	NL = 50 % of rated VA	–	–	–	()	–	()	–
	Complex load	–	–	–	()	–	()	–

* The symbol () denotes a condition to be tested.

4.4 Input voltage

Measurements performed in each of the following tests shall be repeated at three power conditioner input voltages:

- manufacturer's minimum rated input voltage;
- the inverter's nominal voltage (or the average of its rated input range);
- 90 % of the inverter's maximum input voltage.

In the case where a power conditioner is to be connected with a battery at its input terminals, only the nominal or rated input voltage may be applied.

4.5 Ripple and distortion

Record input voltage and current ripple for each measurement. Also record output voltage and current distortion (if a.c.) or ripple (if d.c.). Ensure that these measurements remain within the manufacturer's specified values. Note that ripple and distortion may not be specified at low power levels, but readings shall be recorded.

4.6 Resistive loads/utility grid

At unity power factor, or at the intrinsic power factor of grid-connected inverters without power factor adjustment, measure the efficiency for power levels of 10 %, 25 %, 50 %, 75 %, 100 % and 120 % of the inverter's rating. Stand-alone inverters shall also be measured at a power level of 5 % of rated. The power conditioner test should be conducted with a specified resistive and reactive grid impedance.

4.7 Reactive loads

For stand-alone inverters, measure the efficiency with a load which provides a power factor equal to the manufacturer's specified minimum level (or 0,25, whichever is greater) and at power levels of 25 %, 50 % and 100 % of rated VA. Repeat for power factors of 0,5 and 0,75 (do not go below the manufacturer's specified minimum PF) and power levels of 25 %, 50 %, and 100 % of rated VA.

4.8 Resistive plus non-linear loads

For stand-alone inverters, measure the efficiency with a fixed non-linear load (total harmonic distortion (THD) = $(80 \pm 5) \%$) equal to $(25 \pm 5) \%$ of the inverter's rated VA plus sufficient resistive load in parallel to achieve a total load of 25 %, 50 % and 100 % of rated VA. Repeat the measurements with a fixed non-linear load equivalent to $(50 \pm 5) \%$ of the inverter's rated VA plus sufficient resistive load in parallel to achieve a total load of 50 % and 100 % of rated VA. The type of non-linear load must be clearly stated in all documentation.

4.9 Complex loads

When a non-linear plus a sufficient reactive load condition is specified for stand-alone inverters, measure the efficiency with a fixed non-linear load (THD = $(80 \pm 5) \%$) equal to $(50 \pm 5) \%$ of the inverter's rated VA plus a sufficient reactive load (PF = 0,5) in parallel to achieve a total load of 50 % and 100 % of rated VA. The type of complex load shall be clearly stated in all documentation.

5 Efficiency calculations

5.1 Rated output efficiency

Rated output efficiency shall be calculated from measured data as follows:

$$\eta_R = (P_o / P_i) \times 100 \quad (1)$$

where

η_R is the rated output efficiency (%);

P_o is the rated output power from power conditioner (kW);

P_i is the input power to power conditioner at rated output (kW).

NOTE Any auxiliary input power (kW), such as for the inverter's control system (or gate driver) shall be included in P_i in equation (1).

5.2 Partial output efficiency

Partial output efficiency shall be calculated from measured data as follows:

$$\eta_{par} = (P_{op} / P_{ip}) \times 100 \quad (2)$$

where

η_{par} is the partial output efficiency (%);

P_{op} is the partial output power from power conditioner (kW);

P_{ip} is the input power to power conditioner at partial output (kW).

NOTE Any auxiliary input power (kW) such as for the inverter's control system (or gate driver) shall be included into P_i in equation (2).

5.3 Energy efficiency

Energy efficiency shall be calculated from measured data as follows:

$$\eta_E = (W_o / W_i) \times 100 \quad (3)$$

where

η_E is the energy efficiency (%);

W_o is the output energy during a specified operating period (kWh);

W_i is the input energy during a specified operating period (kWh).

NOTE 1 The operating period and the load profile shall be determined by mutual agreement between user and manufacturer.

NOTE 2 Some auxiliary input energy (kWh) such as for the inverter's control system (or gate driver) shall be included in W_i in equation (3).

NOTE 3 See annex C for an explanation of weighted-average energy efficiency η_{wt} which can supplant the energy efficiency.

5.4 Efficiency tolerances

When an efficiency value has been guaranteed, the tolerance of this value shall be within the value at rated conditions indicated in table 2.

Table 2 – Efficiency tolerances

Item	Tolerance	Remarks
Efficiency of power conditioner	$-0,2(1 - \eta)\eta(\%)$	η : guaranteed efficiency
NOTE The efficiency tolerance is derived in annex D. See 4.3 of IEC 60146-1-1. The tolerance corresponds to +0,2 per unit of the losses with a minimum efficiency tolerance of –0,002 per unit.		

6 Efficiency test circuits

6.1 Test circuits

Figure 1 shows recommended test circuits for power conditioners which have a single-phase a.c. output or d.c. output. It can as well be regarded as a single-phase representation of a test set-up for multiphase power conditioners.

Figures 1a and 1b shall be applied to stand-alone and utility-interactive power conditioners respectively.

The proposed test circuits in figure 1 are not mandatory, but together with the test descriptions, are intended to establish a base for mutual agreement between user and manufacturer.

The type of power source shall be indicated on all tests and shall adhere to the requirements of 4.1.

6.2 Measurement procedure

- a) Efficiency is calculated with equation (1) or (2) using measured P_i , P_o or P_{ip} , P_{op} . DC input power P_i , P_{ip} can be measured by wattmeter W_1 , or determined by multiplying the d.c. voltmeter V_1 and d.c. ammeter A_1 readings. Output power P_o , P_{op} is measured with wattmeter W_2 .
- b) DC input voltage, which is measured by d.c. voltmeter V_1 , shall be varied in the defined range where the output current, which is measured with a.c. ammeter A_2 , is varied from low output to the rated output.
- c) An average indicating instrument shall be used for the d.c. voltmeter and d.c. ammeter. A true r.m.s. type of indicating instrument shall be used for the a.c. voltmeter and a.c. ammeter. The d.c. wattmeter W_1 shall be a d.c. measuring type. The wattmeter W_2 shall be an a.c. or d.c. measuring type according to the output.
- d) Power factor (PF in per cent) can be measured by a power factor meter PF , or calculated from the readings of V_2 , A_2 , W_2 and as follows:

$$PF = (W_2 / (V_2 \times A_2)) \times 100 \quad (4)$$

- e) Each meter may be an analogue type or a digital type. The measurement accuracy shall be better than $\pm 0,5$ % of the full-scale value for each power measured. Digital power instruments for W_1 and W_2 are also recommended.
- f) An MPPT dynamically adjusts the input voltage so as to maximize the output power. In principle, the monitoring equipment shall sample all of the electrical parameters, such as input voltage and current, output power and current, within the update period of the MPPT. If the MPPT and input source (PV array or PV array simulator) interact in such a way that the input voltage varies by less than 5 % then averaging of readings is acceptable. The averaging period shall be 30 s or longer.

7 Loss measurement

IEC 61683:1999

<https://standards.iteh.ai/catalog/standards/sist/27303a7e-a7b7-48fb-a0a9-7e5e5f8a3a7f/iec-61683-1999>

7.1 No-load loss

No-load loss shall be measured as follows.

If the power conditioner is a stand-alone type, the reading of d.c. input voltage, output voltage and frequency is given with meters V_1 , V_2 and F respectively in figure 1a, and shall be adjusted to the rated values.

The no-load loss is thus the indicated value of d.c. input wattmeter, W_1 , when the load is disconnected from the power conditioner.

If the power conditioner is a utility-interactive type, the reading of d.c. input voltmeter V_1 , a.c. output voltmeter V_2 and frequency meter F in figure 1b shall be adjusted to meet the specified voltages and frequency.

No-load loss is thus the indicated value of d.c. input wattmeter, W_1 , when a.c. wattmeter, W_2 , indicates a zero value. For the measurement, allow the power conditioner time to transfer to its no-load operating state, if applicable.

7.2 Standby loss

Standby loss shall be measured as follows.

If the power conditioner is a utility-interactive type, standby loss is defined as the consumption of utility power when the power conditioner is not operating but is under standby condition. Standby loss is indicated with a.c. wattmeter, W_2 in figure 1b at the rated a.c. output voltage.

If the power conditioner is a stand-alone type, standby loss is defined as the consumption from the d.c. source when the power conditioner is not operating but is under standby condition. Standby loss is indicated with d.c. wattmeter, W_1 in figure 1a (without a.c. or d.c. output voltage).

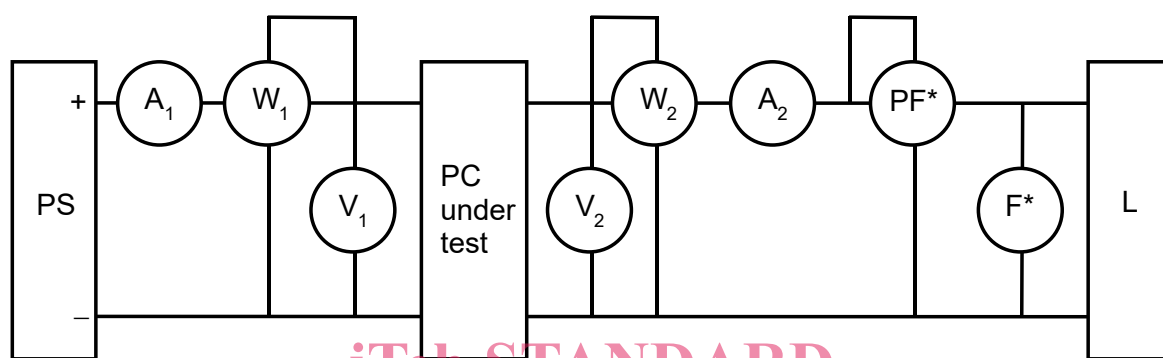

Figure 1a – Stand-alone type

IEC 1566/99

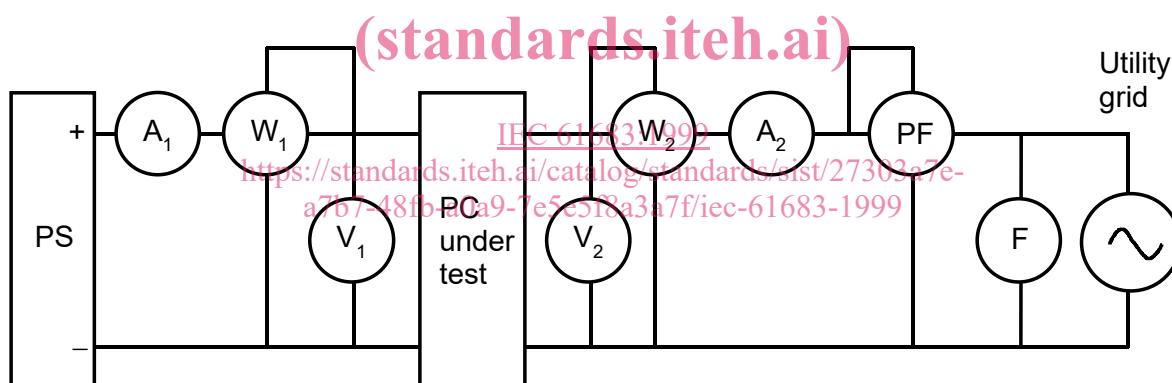

Figure 1b – Utility-interactive type

IEC 1567/99

PC	power conditioner	L	load
PS	variable voltage-current d.c. power supply	F	frequency meter
A_1	DC ammeter	V_1	DC voltmeter
A_2	AC or d.c. ammeter	V_2	AC or d.c. voltmeter
W_1	DC wattmeter	PF	power factor meter
W_2	AC or d.c. wattmeter		

NOTE 1 The d.c. input voltage or current ripple will vary according to the d.c. power supply's internal impedance, and should be defined by mutual agreement between user and manufacturer. For example, the impedance might be selected as the current-voltage ratio $\Delta V/\Delta I$ at the operating point on the PV array I-V curve. When the power conditioner includes the MPPT, a PV array simulator is recommended as the d.c. power source.

NOTE 2 Frequency meter F^* and power factor meter PF^* are ignored in the case of d.c. output.

Figure 1 – Power conditioner test circuits