



Standard Specification for Cold Expansion Fittings with PEX Reinforcing Rings for Use with Cross-linked Polyethylene (PEX) Tubing¹

This standard is issued under the fixed designation F1960; the number immediately following the designation indicates the year of original adoption or, in the case of revision, the year of last revision. A number in parentheses indicates the year of last reapproval. A superscript epsilon (ϵ) indicates an editorial change since the last revision or reapproval.

¹NOTE—~~Figures 1 and 2 and footnote 1 were editorially updated in July 2011.~~

1. Scope*

1.1 This specification covers cold expansion fittings and cross-linked (PEX) reinforcing rings for use with cross-linked polyethylene (PEX) plastic tubing in $\frac{3}{8}$, $\frac{1}{2}$, $\frac{5}{8}$, $\frac{3}{4}$, 1, 1- $\frac{1}{4}$, 1 $\frac{1}{2}$ in. and 2 in. nominal diameters that meet the requirements of Specifications **F876** and **F877**. These fittings are intended for use in 100 psi (690 kPa) cold- and hot-water distribution systems operating at temperatures up to and including 180°F (82°C). The system is comprised of a PEX reinforcing ring and a cold expansion fitting. Included are the requirements for materials, workmanship, dimensions, and markings to be used on the fitting components. The components covered by this specification are intended for use in residential and commercial, hot and cold, potable water distribution systems as well as sealed central heating, including under-floor-heating systems.

1.2 The values stated in inch-pound units are to be regarded as the standard. The values given in parentheses are mathematical conversions to SI units which are provided for information only and are not considered standard.

1.3 *This standard does not purport to address all of the safety concerns, if any, associated with its use. It is the responsibility of the user of this standard to establish appropriate safety and health practices and determine the applicability of regulatory limitations prior to use.*

2. Referenced Documents

2.1 ASTM Standards:²

- [A351/A351M Specification for Castings, Austenitic, for Pressure-Containing Parts](#)
- [B16/B16M Specification for Free-Cutting Brass Rod, Bar and Shapes for Use in Screw Machines](#)
- [B140/B140M Specification for Copper-Zinc-Lead \(Red Brass or Hardware Bronze\) Rod, Bar, and Shapes](#)
- [B62 Specification for Composition Bronze or Ounce Metal Castings](#)
- [B75 Specification for Seamless Copper Tube](#)
- [B283 Specification for Copper and Copper-Alloy Die Forgings \(Hot-Pressed\)](#)
- [B371/B371M Specification for Copper-Zinc-Silicon Alloy Rod](#)
- [B584 Specification for Copper Alloy Sand Castings for General Applications](#)
- [B967/B967M Specification for Copper-Zinc-Tin-Bismuth Alloy Rod, Bar and Wire](#)
- [D792 Test Methods for Density and Specific Gravity \(Relative Density\) of Plastics by Displacement](#)
- [D1505 Test Method for Density of Plastics by the Density-Gradient Technique](#)
- [D1600 Terminology for Abbreviated Terms Relating to Plastics](#)
- [D2122 Test Method for Determining Dimensions of Thermoplastic Pipe and Fittings](#)
- [D2765 Test Methods for Determination of Gel Content and Swell Ratio of Crosslinked Ethylene Plastics](#)
- [D3035 Specification for Polyethylene \(PE\) Plastic Pipe \(DR-PR\) Based on Controlled Outside Diameter](#)
- [D6394 Specification for Sulfone Plastics \(SP\)](#)
- [F412 Terminology Relating to Plastic Piping Systems](#)
- [F876 Specification for Crosslinked Polyethylene \(PEX\) Tubing](#)
- [F877 Specification for Crosslinked Polyethylene \(PEX\) Hot- and Cold-Water Distribution Systems](#)

¹ This specification is under the jurisdiction of ASTM Committee **F17** on Plastic Piping Systems and is the direct responsibility of Subcommittee **F17.10** on Fittings. Current edition approved June 1, 2011; Aug. 1, 2012. Published June 2011. Originally approved in 1999. Last previous edition approved in 2011 as **F1960 – 10; F1960 – 11**¹. DOI: 10.1520/F1960-11E01.10.1520/F1960-12.

² For referenced ASTM standards, visit the ASTM website, www.astm.org, or contact ASTM Customer Service at service@astm.org. For *Annual Book of ASTM Standards* volume information, refer to the standard's Document Summary page on the ASTM website.

*A Summary of Changes section appears at the end of this standard

2.2 *ANSI Standard:*

B1.20 Pipe Threads General Purpose³

B16.18 Cast Copper Alloy Solder Joint Pressure Fittings

B16.22 Wrought Copper and Copper Alloy Solder Joint Pressure Fittings

2.3 *NSF Standards:*

NSF 14 for Plastic Piping Components and Related Materials⁴

NSF 61 for Drinking Water System Components-Health Effects⁴

2.4 *Manufacturers' Standardization Society Standards:*

SP-104 Wrought Copper Solder Joint Pressure Fittings⁵

3. Terminology

3.1 *Definitions:*

3.1.1 Definitions are in accordance with Terminology **F412** and abbreviations are in accordance with Terminology **D1600**, unless otherwise indicated.

3.1.2 *PEX reinforcing rings*—cross-linked polyethylene rings used to add contraction force around the cold expansion fittings.

4. Classification

4.1 This specification covers one class of cold expansion fittings with PEX reinforcing rings suitable for use with PEX tubing that meets the requirements of Specifications **F876** and **F877**.

5. Materials and Manufacture

5.1 Cold expansion fittings shall be made from one of the following materials:

5.1.1 Brass:

5.1.1.1 *Machined Brass*—Machined brass fittings shall be made from material meeting the requirements of Specification **B140/B140M** Copper Alloy UNS No. C31400, or Specification **B16/B16M** copper alloy UNS No. C36000, or Specification **B371/B371M** Copper Alloy UNS No. C69300, or Standard EN 12164, copper alloy CW614N, or Copper Alloy UNS No. C35330, Copper Alloy UNS No. C27450 or Specification **B967/B967M** copper alloy UNS No. C49260 or C49340.

5.1.1.2 *Forged Brass*—Forged brass fittings shall be made from material meeting the requirements of Specification **B283**, Copper Alloy UNS Nos. C27450, C35330, C36500, C37700, C46400, C48600, C49260, C49340, or C69300.

5.1.1.3 *Cast Copper Alloys*—Cast copper alloy fittings shall be made from material meeting the requirements of Specification **B584**, Copper Alloy UNS Nos. C84400, C83800, C87850 or C89844 or C89836 or Specification **B62**, Copper Alloy UNS No. C83600, or Standard EN 1982, copper alloy EN Symbol CuSn4Zn6Pb3–C.

5.1.2 Sulfone:

5.1.2.1 *20 % Glass-Filled Polysulfone*—Polysulfone fittings produced using glass reinforcement shall be molded from polysulfone materials as specified in Specification **D6394**. The polymers shall consist of polysulfone and glass fiber and meet the following line call out for additional properties (SP0113G20A30430).

5.1.2.2 *Unreinforced Sulfone Plastic (SP)*—Fittings shall be molded from sulfone plastic (SP) as specified in Specification **D6394**. The material shall be unreinforced polysulfone (group 01, class 1, grade 2), or polyphenylsulfone (group 3, class 1, grade 2.) Material may also be an unreinforced blend of these two materials with the polyphenylsulfone continuous phase comprising 55 to 80% of the blend.

5.1.2.3 Clean rework material of the same commercial designation, generated for the manufacturer's own production may be used by the same manufacturer, provided the fittings meet all of the requirements of this specification. Rework material shall not be introduced at a ratio exceeding 25%.

5.2 Reinforcing rings shall be made from PEX material meeting the performance requirements of **6.1**.

5.3 *Stainless Steel*—fittings shall be made from material meeting the requirements of Specification **A351/A351M**, stainless steel UNS No. J92800.

5.4 *Wrought Copper*—Wrought copper fittings shall be made from material meeting the requirements of Specification **B75** for one of the following coppers: copper UNS C10200, C10300, C10800, or C12200.

6. General Requirements

6.1 The following sections of Specification **F877** constitute a part of this specification.

6.1.1 Requirements,

³ Available from American National Standards Institute (ANSI), 25 W. 43rd St., 4th Floor, New York, NY 10036, <http://www.ansi.org>

⁴ Available from NSF International, P.O. Box 130140, 789 N. Dixboro Rd., Ann Arbor, MI 48113-0140, <http://www.nsf.org>.

⁵ Available from Manufacturers Standardization Society of the Valve and Fittings Industry (MSS), 127 Park St., NE, Vienna, VA 22180-4602, <http://www.mss-hq.com>.

- 6.1.2 Test Methods, and
- 6.1.3 Retest and Rejection.

6.2 In addition, when a section with a title identical to that referenced in 6.1, above, appears in this specification, it contains additional requirements that supplement those appearing in F877.

6.3 System Performance Requirements:

6.3.1 General—All performance tests shall be performed on assemblies of fittings, PEX reinforcing rings and PEX tubing. Fittings and reinforcing rings shall meet the material and dimensional requirements of this specification. PEX tubing shall meet the requirements of Specifications F876 and F877. Assembly of test specimens shall be in accordance with 10.1. Each assembly shall contain at least two joints. Use separate sets of assemblies for each performance test requirement.

6.3.2 Dimensions—Any randomly selected fitting or fittings and PEX reinforcing rings shall be used to determine dimensions. Measurements shall be made in accordance with Test Method D2122, except determine diameter by making measurements at four locations spaced at approximately 45° apart around the circumference. Inspection and gauging of solder joint ends shall be accordance with ANSI B16.18, ANSI B16.22, or Manufacturers’ Standardization Society SP-104.

7. Performance Requirements

7.1 PEX Reinforcing Rings:

7.1.1 Density—When determined in accordance with 11.1, the PEX reinforcing rings shall have a density in the range from 926 to 940 kg/m³.

7.1.2 Degree of Cross-linking—When tested in accordance with 11.2, the degree of cross-linking for PEX reinforcing rings shall be within the range from 70 to 89% inclusive.

7.1.3 Stabilizer Migration Resistance—When tested in accordance with 11.3, the time t², shall be at least 50% of the time, t¹.

8. Dimensions

8.1 Dimensions and Tolerances—The dimensions and tolerances of fittings and PEX reinforcing rings shall be as shown in Figs. 1 and 2 and Fig. 4 when measured in accordance with 6.3.2.

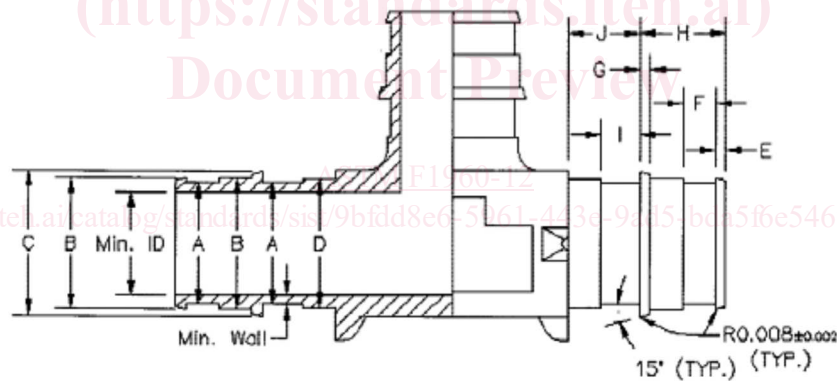

NOTE-BREAK ALL INTERNAL CORNERS .003-.015
ALL DIAMETER CONCENTRICITY .005 TIR

Brass, Stainless Steel and Wrought Copper Dimensions

Size	Min. Wall	Min. ID	A	B	C	D	E	F	G	H	I	J
3/8 in.	0.047	0.260	0.375	0.433	0.472	0.407	0.051	0.108	0.051	0.305	0.107	0.266
			0.395	0.441	0.480	0.427	0.067	0.128	0.067	0.325	0.127	0.286
1/2 in.	0.057	0.378	0.513	0.571	0.610	0.545	0.051	0.108	0.051	0.384	0.147	0.305
			0.533	0.579	0.618	0.565	0.067	0.128	0.067	0.404	0.167	0.325
5/8 in.	0.057	0.500	0.635	0.689	0.740	0.663	0.051	0.147	0.051	0.462	0.187	0.384
			0.655	0.697	0.748	0.683	0.067	0.167	0.067	0.482	0.207	0.404
3/4 in.	0.057	0.595	0.728	0.787	0.866	0.762	0.051	0.187	0.051	0.502	0.226	0.423
			0.748	0.795	0.874	0.782	0.067	0.207	0.067	0.522	0.246	0.443
1 in.	0.072	0.795	0.965	1.024	1.102	0.978	0.051	0.226	0.051	0.620	0.265	0.541
			0.985	1.032	1.110	0.998	0.067	0.246	0.067	0.640	0.285	0.561
1-1/4 in.	0.075	0.960	1.139	1.266	1.352	1.217	0.064	0.279	0.064	0.761	0.328	0.664
			1.159	1.276	1.362	1.237	0.080	0.299	0.080	0.781	0.348	0.684
1-1/2 in.	0.095	1.084	1.304	1.374	1.486	1.329	0.077	0.331	0.077	0.899	0.388	0.785
			1.324	1.382	1.494	1.349	0.093	0.351	0.093	0.919	0.408	0.805
2 in.	0.095	1.550	1.800	1.958	2.079	1.891	0.093	0.467	0.093	1.137	0.521	1.030
			1.780	1.950	2.071	1.871	0.077	0.447	0.077	1.117	0.501	1.010

FIG. 1 Brass and Stainless Steel and Wrought Copper Insert Dimensions and Tolerances

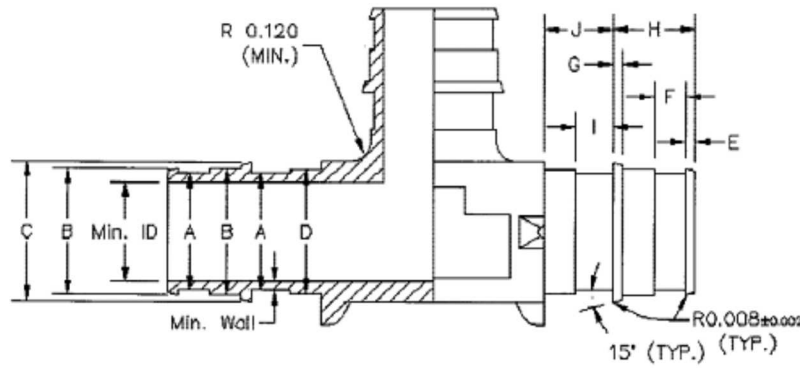

NOTE-BREAK ALL INTERNAL CORNERS .003-.015
ALL DIAMETER CONCENTRICITY .005 TIR

Sulfone Dimensions

Size	Min. Wall	Min. ID	A	B	C	D	E	F	G	H	I	J	Max Flash and Mismatch
3/8 in.	0.047	0.268	0.382	0.433	0.472	0.407	0.051	0.108	0.051	0.305	0.108	0.266	0.005
			0.402	0.441	0.480	0.427	0.067	0.128	0.067	0.325	0.128	0.306	
1/2 in.	0.057	0.385	0.520	0.571	0.610	0.545	0.051	0.108	0.051	0.384	0.147	0.305	0.005
			0.540	0.579	0.618	0.565	0.067	0.128	0.067	0.404	0.167	0.345	
5/8 in.	0.057	0.494	0.628	0.689	0.740	0.663	0.051	0.147	0.051	0.462	0.187	0.384	0.005
			0.648	0.697	0.748	0.683	0.067	0.167	0.067	0.482	0.207	0.424	
3/4 in.	0.057	0.590	0.735	0.787	0.866	0.762	0.051	0.187	0.051	0.502	0.226	0.423	0.005
			0.755	0.795	0.874	0.782	0.067	0.207	0.067	0.522	0.246	0.463	
1 in.	0.072	0.788	0.972	1.024	1.102	0.978	0.051	0.226	0.051	0.620	0.266	0.541	0.005
			0.992	1.032	1.110	0.998	0.067	0.246	0.067	0.640	0.286	0.581	
1-1/4 in.	0.075	0.970	1.139	1.266	1.352	1.217	0.064	0.279	0.064	0.761	0.328	0.664	0.005
			1.159	1.276	1.362	1.237	0.080	0.299	0.080	0.781	0.348	0.704	
1-1/2 in.	0.095	1.084	1.308	1.374	1.486	1.329	0.077	0.331	0.077	0.899	0.388	0.785	0.005
			1.328	1.382	1.494	1.349	0.093	0.351	0.093	0.919	0.408	0.825	
2	0.128	1.484	1.800	1.958	2.079	1.891	0.093	0.467	0.093	1.137	0.521	1.050	0.005
			1.780	1.950	2.071	1.871	0.077	0.447	0.077	1.117	0.501	1.010	

FIG. 2 Sulfone Insert Dimensions and Tolerances

<https://standards.iteh.ai/catalog/standards/sist/9bfdd8e6-5961-443e-9ad5-bda5f6e5469b/astm-f1960-12>

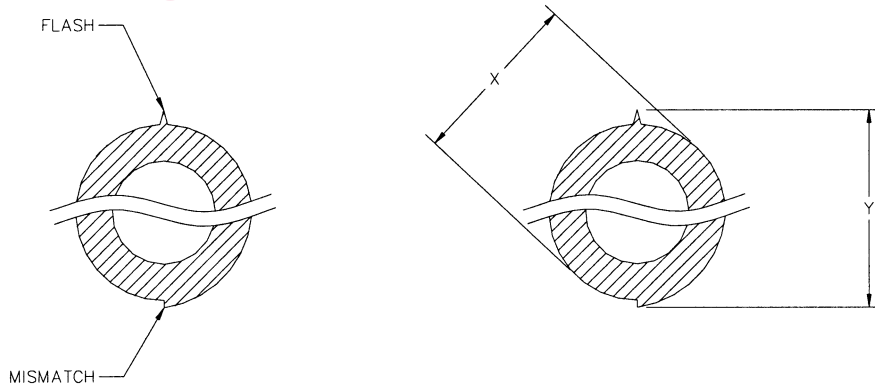
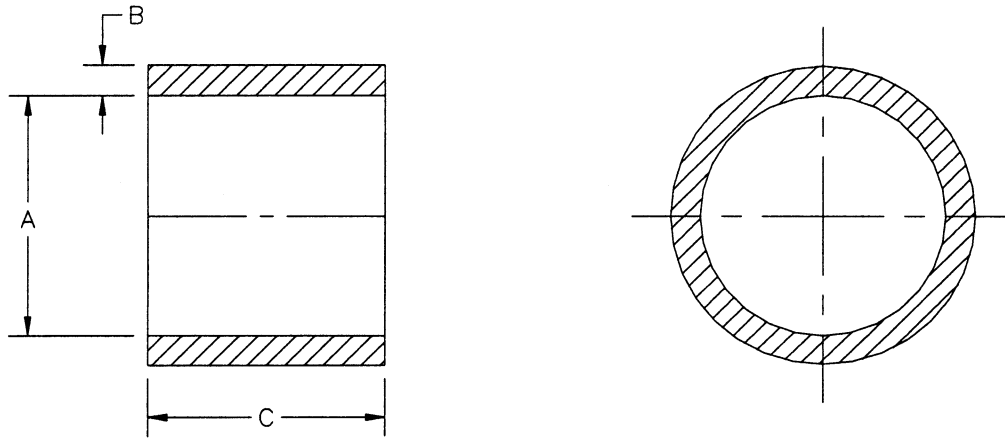

FIG. 3 Flash and Mismatch Created by Imperfection in Die Half Interfaces

8.1.1 *Alignment*—The maximum angular variation of any opening shall not exceed 1° off the true centerline axis.

8.1.2 *Fittings with Solder Joint Ends*—Solder joint ends shall be in accordance with ANSI B16.22, ANSI B16.18 or MSS SP-104.

8.1.3 *Tapered Threaded Ends*—Fitting threads shall be right-hand conforming to ANSI B1.20.1. They shall be taper threads (NPT).



Tube Size	Inside Diameter (A)	Max. out of Round	Wall Thickness (B)	Width (C)
3/8 in.	0.486 ± 0.004	0.012	0.123 ± 0.006	0.540 ± 0.020
1/2 in.	0.633 ± 0.003	0.012	0.123 ± 0.005	0.630 ± 0.020
5/8 in.	0.757 ± 0.003	0.012	0.123 ± 0.005	0.787 ± 0.020
3/4 in.	0.882 ± 0.004	0.016	0.123 ± 0.005	0.866 ± 0.020
1 in.	1.134 ± 0.004	0.020	0.143 ± 0.006	1.102 ± 0.030
1-1/4 in.	1.382 ± 0.004	0.020	0.138 ± 0.006	1.349 ± 0.040
1-1/4 in.	1.388 ± 0.004	0.035	0.138 ± 0.006	1.349 ± 0.040
1-1/2 in.	1.634 ± 0.004	0.020	0.138 ± 0.006	1.605 ± 0.040
1-1/2 in.	1.642 ± 0.004	0.035	0.138 ± 0.006	1.605 ± 0.040
2 in.	2.136 ± 0.004	0.025	0.236 ± 0.012	1.968 ± 0.040
2 in.	2.154 ± 0.004	0.080	0.236 ± 0.012	1.968 ± 0.040

ITeH Standards
 (https://standards.iteh.ai)
 Document Preview

9. Workmanship, Finish, and Appearance

9.1 The fittings shall be made from compounds that are homogeneous throughout. The sealing surfaces of the insert shall be smooth and free of foreign material. The fitting walls shall be free of cracks, holes, blisters, voids, foreign inclusions, or other defects that are visible to the naked eye and that affect wall integrity.

10. Assembly

10.1 *Cold Expansion Joints*—Fittings shall be joined to PEX tubing by the contraction of the tubing and reinforcing ring over the insert of the cold expansion fitting. Fittings and PEX reinforcing rings shall meet the dimensional and material requirements of this standard. PEX tubing shall meet the requirements of Specification F876 or F877.

10.2 *Expansion Tool*—The expansion tool shall expand the PEX tubing and reinforcing ring to a maximum inside diameter as listed in Table 1. The expanded tubing shall be round to ensure uniform contraction of the tubing around the cold expansion fitting. The expansion tool shall be inspected for wear according to the manufacturer’s instructions.

10.3 *Procedure:*

10.3.1 *Assembly of Connections*—Affix the cold expansion fitting to the PEX tubing by sliding the PEX reinforcing ring onto the tubing and positioning the ring so that the end of the ring overhangs the end of the tubing a maximum of 1/16 in. (1.6 mm). Insert the expansion head into the tubing as far as it will go. Holding the tool so that the centerline of the expansion head is approximately in line with the centerline of the tubing, operate the tool until the tubing and reinforcing ring are fully expanded. After completing the expansion process, remove the expansion tool and insert the cold expansion fitting until the tubing hits the shoulder of the fitting or the tube stop. Hold the fitting in place until the tubing contracts sufficiently to hold the fitting in place.

10.3.2 *Improper Connections*—If the insert fitting was not fully inserted to its shoulder or tube stop or the reinforcing ring was not placed in accordance with 10.3.1, remove the tubing and ring from the fitting and trim 2 in. from the tubing. Using a new reinforcing ring, repeat the procedure in 10.3.1.

11. Reinforcing Ring Testing Methods

11.1 *Density*—Determine the density of the reinforcing ring material in accordance with Test Method D1505, or Test Method D792, using three specimens.

11.2 *Degree of Cross-Linking*—Determine the degree of cross-linking in accordance with Test Method D2765, Method B except for the following: during sample preparation, place a reinforcing ring in a lathe with automatic feeding. Shave a strip approximately

NOTE 1—All dimensions shall be measured with appropriate micrometers, such as pin or ball micrometers for wall thickness and outside diameter micrometers with flat anvils to measure outside diameter and width of rings.

0.004 in.-thick that consists of the full thickness of the ring. For the purpose of this specification, the degree of cross-linking (V) is defined as 100 % minus the extract percent = V .

11.3 *Stabilizer Migration Resistance*—Cut two 0.4-in. (10-mm) long samples from the reinforcing ring. Store one of the samples covered at room temperature for 1000 h. Place the other sample in a round-bottom flask with large-mouth, ground-glass or cork joint. The flask size shall be 500 mL for each test sample. Fill with distilled water. Put the flask in a heating mantle to heat the flask to boil water. Put a reflux condenser with ground-glass or cork joint to fit into the flask. Boil for 1000 h but change the distilled water at even intervals two times per week. Place the two samples hanging on a thin steel rod (approximately 0.1-in. (2.5-mm) diameter) in an oven at 311°F (155°C) in accordance with Practice **D3035**. Let the samples hang in the oven until both have failed. Failure is an obvious change in the shape or color of the samples, observed visually. The start of melting of surfaces, drip formation, or cracks indicates a shape change. Color change must be significant if it shall be counted as a failure. Observation of the tube samples must be made at intervals making it possible to read the time-to-failure within 15 % of the total testing time. Measure the time-to-failure of the unboiled sample (t_1) and the boiled sample (t_2).

12. Product Marking

12.1 *Cold Expansion Fitting:*

12.1.1 *Quality of Marking*—The marking shall be applied to the fittings in such a manner that it remains legible after installation and inspection.

12.1.2 *Content of Marking:*

12.1.2.1 Manufacturer's name or trademark, or both,

12.1.2.2 This designation, F1960,

12.1.2.3 Certification mark or seal of the laboratory making the evaluation for this purpose, and

12.1.2.4 Nominal size.

12.1.3 Where recessed marking is used on the fittings, in no case shall the marking cause cracks or reduce the wall thickness below the minimum specified.

12.2 *PEX Reinforcing Rings*—The product shall be marked with the following information:

12.2.1 Manufacturer's name or trademark, or both,

12.2.2 Nominal size,

12.2.3 Certification mark or seal of the laboratory making the evaluation for this purpose, and

12.2.4 This designation, F1960.

13. Quality Assurance

13.1 When the product is marked with this designation (ASTM F1960), the manufacturer affirms that the product was manufactured, inspected, sampled, and tested in accordance with this specification and has been found to meet the requirements of this specification.

14. Keywords

14.1 cold expansion fittings; cross-linked polyethylene; hot and cold water distribution; PEX; PEX reinforcing rings