



Designation: **C1231/C1231M—10a** C1231/C1231M – 12

## Standard Practice for Use of Unbonded Caps in Determination of Compressive Strength of Hardened Concrete Cylinders<sup>1</sup>

This standard is issued under the fixed designation C1231/C1231M; the number immediately following the designation indicates the year of original adoption or, in the case of revision, the year of last revision. A number in parentheses indicates the year of last reappraisal. A superscript epsilon ( $\epsilon$ ) indicates an editorial change since the last revision or reappraisal.

### 1. Scope\*

1.1 This practice covers requirements for a capping system using unbonded caps for testing concrete cylinders molded in accordance with Practice **C31/C31M** or **C192/C192M**. *Unbonded neoprene caps of a defined hardness are permitted to be used for testing for a specified maximum number of reuses without qualification testing up to a certain concrete compressive strength level. Above that strength, level neoprene caps will require qualification testing. Qualification testing is required for all elastomeric materials other than neoprene regardless of the concrete strength.*

1.2 Unbonded caps are not to be used for acceptance testing of concrete with compressive strength below 1500 psi [10 MPa] or above 12 000 psi [80 MPa].

1.3 The values stated in either SI units or inch-pound units are to be regarded separately as standard. The values stated in each system may not be exact equivalents; therefore, each system shall be used independently of the other. Combining values from the two systems may result in non-conformance with the standard.

1.4 *This standard does not purport to address all of the safety concerns, if any, associated with its use. It is the responsibility of the user of this standard to establish appropriate safety and health practices and determine the applicability of regulatory limitations prior to use. (Warning—Concrete cylinders tested with unbonded caps rupture more violently than comparable cylinders tested with bonded caps. The safety precautions given in the Manual of Aggregate and Concrete Testing are recommended.)<sup>2</sup>*

### 2. Referenced Documents

2.1 *ASTM Standards:*<sup>3</sup>

**C31/C31M** Practice for Making and Curing Concrete Test Specimens in the Field

**C39/C39M** Test Method for Compressive Strength of Cylindrical Concrete Specimens

**C192/C192M** Practice for Making and Curing Concrete Test Specimens in the Laboratory <https://doi.org/10.1520/C1231-C1231M-12>

**C617** Practice for Capping Cylindrical Concrete Specimens

**D2000** Classification System for Rubber Products in Automotive Applications

### 3. Terminology

3.1 *Definitions of Terms Specific to This Standard:*

3.1.1 *pad, n*—an unbonded elastomeric pad.

3.1.2 *unbonded cap, n*—a metal retainer and an elastomeric pad.

### 4. Significance and Use

4.1 This practice provides for using an unbonded capping system in testing hardened concrete cylinders made in accordance with Practices **C31/C31M** or **C192/C192M** in lieu of the capping systems described in Practice **C617**.

<sup>1</sup> This practice is under the jurisdiction of ASTM Committee C09 on Concrete and Concrete Aggregates and is the direct responsibility of Subcommittee C09.61 on Testing for Strength.

Current edition approved Oct. 1, 2010; Nov. 15, 2012. Published November 2010/December 2012. Originally approved in 1993. Last previous edition approved in 2010 as C1231/C1231M-10-10a. DOI: 10.1520/C1231-C1231M-10a; 10.1520/C1231-C1231M-12.

<sup>2</sup> Section on Safety Precautions, Manual of Aggregate and Concrete Testing, *Annual Book of ASTM Standards*, Vol. 04.02.

<sup>3</sup> For referenced ASTM standards, visit the ASTM website, [www.astm.org](http://www.astm.org), or contact ASTM Customer Service at [service@astm.org](mailto:service@astm.org). For *Annual Book of ASTM Standards* volume information, refer to the standard's Document Summary page on the ASTM website.

\*A Summary of Changes section appears at the end of this standard

4.2 The elastomeric pads deform in initial loading to conform to the contour of the ends of the cylinder and are restrained from excessive lateral spreading by plates and metal rings to provide a uniform distribution of load from the bearing blocks of the testing machine to the ends of the concrete or mortar cylinders.

## 5. Materials and Apparatus

5.1 Materials and equipment necessary to produce ends of the reference cylinders that conform to planeness requirements of Test Method **C39/C39M** and the requirements of Practice **C617**. This may include grinding equipment or capping materials and equipment to produce neat cement paste, high strength gypsum plaster, or sulfur mortar caps.

### 5.2 Elastomeric Pads:

5.2.1 Pads shall be  $\frac{1}{2} \pm \frac{1}{16}$  in. [ $13 \pm 2$  mm] thick and the diameter shall not be more than  $\frac{1}{16}$  in. [2 mm] smaller than the inside diameter of the retaining ring.

5.2.2 Pads shall be made from polychloroprene (neoprene) meeting the requirements of Classification **D2000** as follows:

Shore A Durometer	Classification <b>D2000</b> Line Call-Out
50	M2BC514
60	M2BC614
70	M2BC714

The tolerance on Shore A durometer hardness is  $\pm 5$ . **Table 1** provides requirements for use of caps made from material meeting the requirements of Classification **D2000**, above.

5.2.3 Other elastomeric materials that meet the performance requirements of qualification tests in Section 8 are permitted.

5.2.4 Elastomeric pads shall be supplied with the following information:

5.2.4.1 The manufacturer's or supplier's name,

5.2.4.2 The Shore A hardness, and

5.2.4.3 The applicable range of concrete compressive strength from **Table 1** or from qualification testing.

5.2.5 The user shall maintain a record indicating the date the pads are placed in service, the pad durometer, and the number of uses to which they have been subjected.

5.3 *Retainers*, are a pair of metal fixtures used to provide support for and alignment of the neoprene pads and the cylinder ends (See **Note 1** and **Fig. 1**). Each retainer (upper and lower) includes a (retaining) ring that is welded to or manufactured integrally with a base plate. The height of the retaining ring shall be  $25 \pm 3$  mm [ $1.0 \pm 0.1$  in.]. The inside diameter of the retaining ring shall not be less than 102 % or greater than 107 % of the diameter of the cylinder. The thickness of the retaining ring shall be at least 12 mm [0.47 in.] for 150 mm [6 in.] diameter retainers and at least 9 mm [0.35 in.] for 100 mm [4 in.] diameter retainers. The surface of the base plate that contacts the bearing block of the testing machine shall be plane to within 0.05 mm [0.002 in.]. The thickness of the base plate shall be at least 12 mm [0.47 in.] for 150 mm [6 in.] retainers and at least 8 mm [0.3 in.] for 100 mm [4 in.] retainers. The bearing surfaces of the retainers shall not have gouges, grooves, protrusions, or indentations greater than 0.25 mm [0.010 in.] deep or greater than 32 mm<sup>2</sup> [0.05 in.<sup>2</sup>] in surface area.

NOTE 1—Retainers made from steel and some aluminum alloys have been found acceptable.

## 6. Test Specimens

6.1 The specimens shall be either 6 by 12 in. [150 by 300 mm] or 4 by 8 in. [100 by 200 mm] cylinders made in accordance with Practices **C31/C31M** or **C192/C192M**. Neither end of a cylinder shall depart from perpendicularity to the axis by more than 0.5° (approximately **Note 2** equivalent to)  $\frac{1}{8}$  in. in 12 in. [3 mm in 300 mm]). No individual diameter of a cylinder may differ from any other diameter by more than 2 %.

**TABLE 1 Requirements for Use of Polychloroprene (Neoprene) Pads**

Compressive Strength, <sup>A</sup> psi [MPa]	Shore A Durometer Hardness	Qualification Tests Required	Maximum Reuses <sup>B</sup>
Less than 1500 [10]		Not permitted	
<del>1 500 to 6 000 [10 to 40]</del>	50	None	400
1500 to 6000 [10 to 40]	50	None	100
<del>2 500 to 7 000 [17 to 50]</del>	60	None	400
2500 to 7000 [17 to 50]	60	None	100
<del>4 000 to 7 000 [28 to 50]</del>	70	None	400
4000 to 7000 [28 to 50]	70	None	100
<del>7 000 to 12 000 [50 to 80]</del>	70	Required	50
7000 to 12,000 [50 to 80]	70	Required	50
Greater than 12,000 [80]		Not permitted	

<sup>A</sup>Compressive strength of concrete at age of testing as specified in Contract Documents. For acceptance testing, it is the specified compressive strength  $f'_c$ .

<sup>B</sup> Maximum number of reuses will be less if pads wear, crack or split. See 7.2.

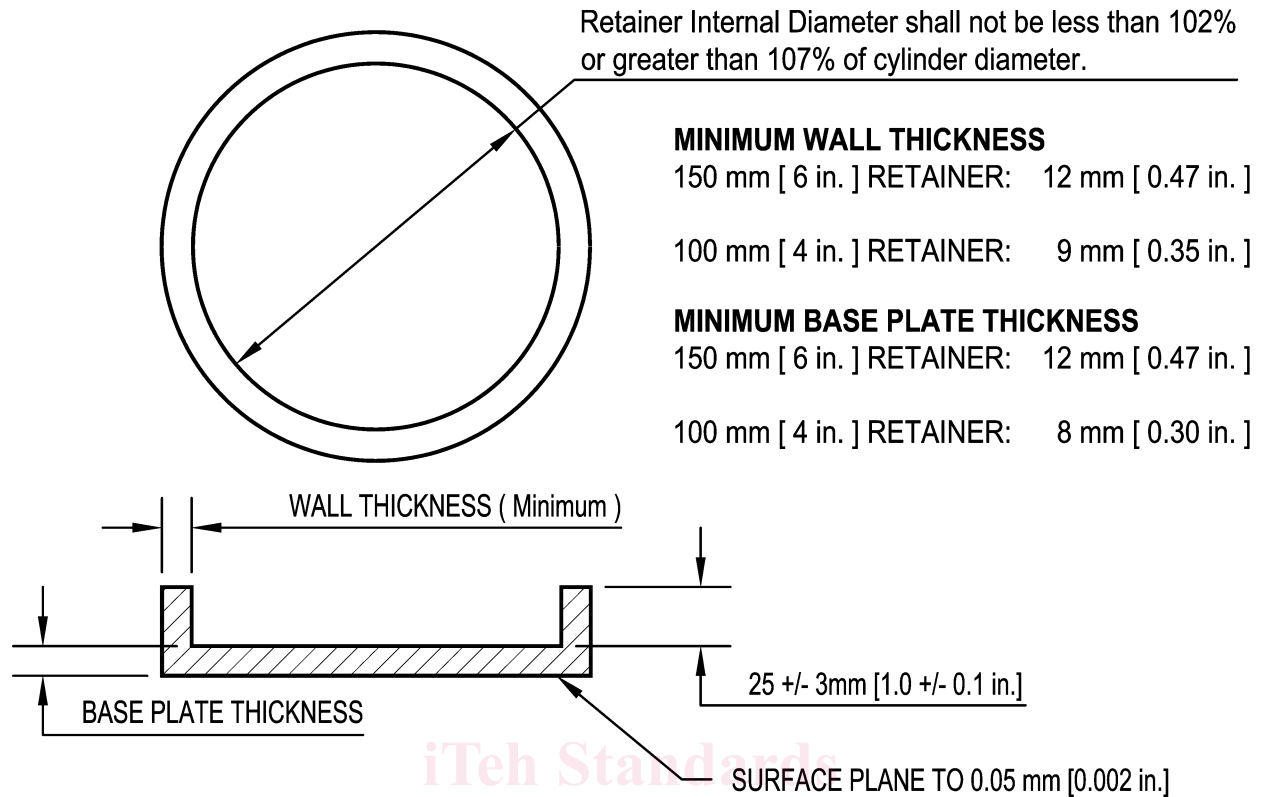

FIG. 1 Example of Retaining Ring and Base Plate

NOTE 2—One method of measuring the perpendicularity of ends of cylinders is to place a try square across any diameter and measure the departure of the longer blade from an element of the cylindrical surface. An alternative method is to place the end of the cylinder on a plane surface and support the try square on that surface. A deviation from perpendicularity of  $0.5^\circ$  is equal to a slope of approximately 1 mm in 100 mm [ $\frac{1}{8}$  in. in 12 in.].

6.2 Depressions under a straight edge measured with a round wire gage across any diameter shall not exceed 0.20 in. [5 mm]. If cylinder ends do not meet this tolerance, the cylinder shall not be tested unless irregularities are corrected by sawing or grinding.

## 7. Procedure

7.1 Unbonded caps are permitted to be used on one or both ends of a cylinder in lieu of a cap or caps meeting Practice C617, provided the caps meet the requirements of Section 5. Pad hardness shall be in accordance with Table 1. (See Note 3)

NOTE 3—The specified strength in the contract documents is for various stages of construction. This may include strength test requirements for formwork removal or release of prestress in addition to the test requirements for verification of specified compressive strength. Therefore, pad selection is based on the strength requirement for the designated stage of construction.

7.2 Examine both sides of pads for excessive wear or damage. Replace pads that have cracks or splits in their top or bottom surface that exceed  $\frac{3}{8}$  in. [10 mm] in length regardless of depth. Insert pad in the retainer before it is placed on the cylinder (Note 4).

NOTE 4—Some manufacturers recommend dusting the pads and the ends of the cylinders with corn starch or talcum powder prior to testing.

7.3 Center the unbonded cap or caps on the cylinder and place the cylinder on the lower bearing block of the testing machine. Carefully align the axis of the cylinder with the center of thrust of the testing machine by centering the upper retaining ring on the spherically seated bearing block. As the spherically seated block is brought to bear on the upper retaining ring, rotate its movable portion gently by hand so that uniform seating is obtained. After application of load, but before reaching 10 % of the anticipated specimen strength, check to see that the axis of the cylinder is vertical within a tolerance of does not depart from vertical by more than  $0.5^\circ$  [ $\frac{1}{4}$  (Note 5 in. in 12 in. [3.2 mm in 300 mm])] and that the ends of the cylinder are centered within the retaining rings. If the cylinder alignment does not meet these requirements, release the load, check compliance with 6.1, and carefully recenter the specimen. Reapply load and recheck specimen centering and alignment. A pause in load application to check cylinder alignment is permissible.

NOTE 5—An angle of  $0.5^\circ$  is equal to a slope of approximately 1 mm in 100 mm [ $\frac{1}{8}$  in. in 12 in.].

7.4 Complete the load application, testing, calculation, and reporting of results in accordance with Test Method C39/C39M (see Notes 56 and 67).