



# SLOVENSKI STANDARD

## SIST EN 28676:1996

01-april-1996

---

### Vijaki s šest robo glavo z metriskim drobnim navojem - Razreda izdelave A in B

Hexagon head screws with metric fine pitch thread - Product grades A and B (ISO 8676:1988)

Sechskantschrauben mit Gewinde bis Kopf - Metrisches Feingewinde - Produktklassen A und B (ISO 8676:1988)

Vis a tete hexagonale, a filetage métrique a pas fin - Grades A et B (ISO 8676:1988)

iTeh STANDARD PREVIEW

(standards.iteh.ai)

Ta slovenski standard je istoveten z: **EN 28676:1991**

SIST EN 28676:1996  
<https://standards.iteh.ai/catalog/standards/sist/e1752441-c8f5-4d18-810d-831ca8b7e143/sist-en-28676-1996>

---

#### **ICS:**

21.040.10	Metriski navoji	Metric screw threads
21.060.10	Sorniki, vijaki, stebelni vijaki	Bolts, screws, studs

**SIST EN 28676:1996**

**en**

**iTeh STANDARD PREVIEW**  
**(standards.iteh.ai)**

SIST EN 28676:1996

<https://standards.iteh.ai/catalog/standards/sist/e1732f41-e8f5-4d18-810d-831ca8b7e143/sist-en-28676-1996>

EUROPEAN STANDARD

EN 28676:1991

NORME EUROPEENNE

EUROPAISCHE NORM

October 1991

UDC 621.882.211

Descriptors : Fasteners, screws, hexagonal head screws, screw threads, specifications, dimensions, designation

## English version

Hexagon head screws with metric fine pitch thread  
- Product grades A and B (ISO 8676:1988)

Vis à tête hexagonale, à filetage  
métrique à pas fin - Grades A et B (ISO  
8676:1988)

Sechskantschrauben mit Gewinde bis  
Kopf - Metrisches Feingewinde - Produktklassen  
A und B (ISO 8676:1988)

This European Standard was approved by CEN on 1991-10-10 and is identical to the ISO standard as referred to.

CEN members are bound to comply with the CEN/CENELEC Internal Regulations which stipulate the conditions for giving this European Standard the status of a national standard without any alteration.

Up-to-date lists and bibliographical references concerning such national standards may be obtained on application to the Central Secretariat or to any CEN member.

SIST EN 28676:1996

<https://standards.iteh.ai/catalog/standards/sist/e1732f41-e8f5-4d18-810d-331a8b707e81-0128676-1996>

This European Standard exists in three official versions (English, French, German). A version in any other language made by translation under the responsibility of a CEN member into its own language and notified to the Central Secretariat has the same status as the official versions.

CEN members are the national standards bodies of Austria, Belgium, Denmark, Finland, France, Germany, Greece, Iceland, Ireland, Italy, Luxembourg, Netherlands, Norway, Portugal, Spain, Sweden, Switzerland and United Kingdom.

CEN

European Committee for Standardization  
Comité Européen de Normalisation  
Europäisches Komitee für Normung

Central Secretariat: rue de Stassart 36, B-1050 Brussels

(c) CEN 1991 Copyright reserved to all CEN members

Ref. No. EN 28676:1991 E

### FOREWORD

In 1990, ISO 8676:1988 was submitted to the CEN P.Q.-procedure.

Following the positive result of the P.Q., CEN/BT agreed to submit ISO 8676:1988 with the following modifications to Formal Vote.

In the French version replace :

- "boulon" by : "vis partiellement filetée"
- "vis" by : "vis entièrement filetée".

In accordance with the Common CEN/CENELEC Rules, the following countries are bound to implement this European Standard :

Austria, Belgium, Denmark, Finland, France, Germany, Greece, Iceland, Ireland, Italy, Luxembourg, Netherlands, Norway, Portugal, Spain, Sweden, Switzerland and United Kingdom.

(standards.iteh.ai)

#### Endorsement notice 996

<https://standards.iteh.ai/catalog/standards/sist/e1732f41-e8f5-4d18-810d-831ca8b7e143/sist-en-28676-1996>

The text of the International Standard ISO 8676:1988 was approved by CEN as a European Standard with agreed common modifications as given above.

# INTERNATIONAL STANDARD

ISO  
8676

First edition  
1988-10-01



INTERNATIONAL ORGANIZATION FOR STANDARDIZATION  
ORGANISATION INTERNATIONALE DE NORMALISATION  
МЕЖДУНАРОДНАЯ ОРГАНИЗАЦИЯ ПО СТАНДАРТИЗАЦИИ

## Hexagon head screws with metric fine pitch thread — Product grades A and B

*Vis à tête hexagonale, à filetage métrique à pas fin — Grades A et B*

**ITeH STANDARD PREVIEW**

**(standards.iteh.ai)**

SIST EN 28676:1996

<https://standards.iteh.ai/catalog/standards/sist/e1732f41-e8f5-4d18-810d-831ca8b7e143/sist-en-28676-1996>

ISO 8676 : 1988 (E)

## Foreword

ISO (the International Organization for Standardization) is a worldwide federation of national standards bodies (ISO member bodies). The work of preparing International Standards is normally carried out through ISO technical committees. Each member body interested in a subject for which a technical committee has been established has the right to be represented on that committee. International organizations, governmental and non-governmental, in liaison with ISO, also take part in the work. ISO collaborates closely with the International Electrotechnical Commission (IEC) on all matters of electrotechnical standardization.

Draft International Standards adopted by the technical committees are circulated to the member bodies for approval before their acceptance as International Standards by the ISO Council. They are approved in accordance with ISO procedures requiring at least 75 % approval by the member bodies voting.

(standards.iteh.ai)

International Standard ISO 8676 was prepared by Technical Committee ISO/TC 2, *Fasteners*.

[SIST EN 28676:1996](#)

<https://standards.iteh.ai/catalog/standards/sist/e1732f41-e8f5-4d18-810d->

Users should note that all International Standards undergo revision from time to time and that any reference made herein to any other International Standard implies its latest edition, unless otherwise stated.

# Hexagon head screws with metric fine pitch thread — Product grades A and B

## 0 Introduction

iTeh STANDARD PREVIEW

(standards.iteh.ai)

This International Standard is part of the complete ISO product standard series on hexagon drive fasteners. The series comprises:

- a) hexagon head bolts (ISO 4014, ISO 4015, ISO 4016 and ISO 8765);
- b) hexagon head screws (ISO 4017, ISO 4018 and ISO 8676);
- c) hexagon nuts (ISO 4032, ISO 4033, ISO 4034, ISO 4035, ISO 4036, ISO 8673, ISO 8674 and ISO 8675);
- d) hexagon flanged bolts (ISO 4162 and ISO 8102);
- e) hexagon flanged screws;<sup>1)</sup>
- f) hexagon flanged nuts (ISO 4161, ISO 7043 and ISO 7044);
- g) structural bolting (ISO 4775, ISO 7411 to ISO 7414, and ISO 7417).

## 1 Scope and field of application

This International Standard gives specifications for hexagon head screws with metric fine pitch thread with nominal thread diameters from 8 to 64 mm, of product grade A for nominal thread diameters from 8 to 24 mm and nominal lengths,  $l$ , up to and including  $10d$  or 150 mm, whichever is shorter, and of product grade B for nominal thread diameters over 24 mm or nominal lengths,  $l$ , over  $10d$  or 150 mm, whichever is shorter.

If, in special cases, specifications other than those listed in this International Standard are required, they should be selected from existing International Standards, for example ISO 261, ISO 888, ISO 898-1, ISO 965-2, ISO 3506 and ISO 4759-1.

Coarse thread screws according to ISO 4017 should be first choice.

1) These will form the subjects of future International Standards.

## ISO 8676 : 1988 (E)

**2 References**

ISO 225, *Fasteners — Bolts, screws and nuts — Symbols and designations of dimensions.*

ISO 261, *ISO general purpose metric screw threads — General plan.*

ISO 262, *ISO general purpose metric screw threads — Selected sizes for screws, bolts and nuts.*

ISO 888, *Bolts, screws and studs — Nominal lengths and thread lengths for general purpose bolts and screws.*

ISO 898-1, *Mechanical properties of fasteners — Part 1: Bolts, screws and studs.*

ISO 965-2, *ISO general purpose metric screw threads — Tolerances — Part 2 : Limits of sizes for general purpose bolt and nut threads — Medium quality.*

ISO 3269, *Fasteners — Acceptance inspection.*

ISO 3506, *Corrosion-resistant stainless steel fasteners — Specifications.*

ISO 4042, *Threaded components — Electroplated coatings.*<sup>1)</sup>

ISO 4753, *Fasteners — Ends of parts with external metric ISO thread.*

ISO 4759-1, *Tolerances for fasteners — Part 1: Bolts, screws and nuts with thread diameters > 1,6 and < 150 mm and product grades A, B and C.*

ISO 6157-1, *Fasteners — Surface discontinuities — Part 1 : Bolts, screws and studs for general requirements.*

ISO 6157-3, *Fasteners — Surface discontinuities — Part 3 : Bolts, screws and studs for special requirements.*

ISO 8839, *Mechanical properties of fasteners — Bolts, screws, studs and nuts made of non-ferrous metals.*

ISO 8992, *Fasteners — General requirements for bolts, screws and nuts.*

SIST EN 28676:1996  
<https://standards.iteh.ai/catalog/standards/sist/e1732f41-e8f5-4d18-810d-831ca8b7e143/sist-en-28676-1996>

1) At present at the stage of draft.



### 3 Dimensions

NOTE — Symbols and designations for dimensions are specified in ISO 225.

Dimensions in millimetres

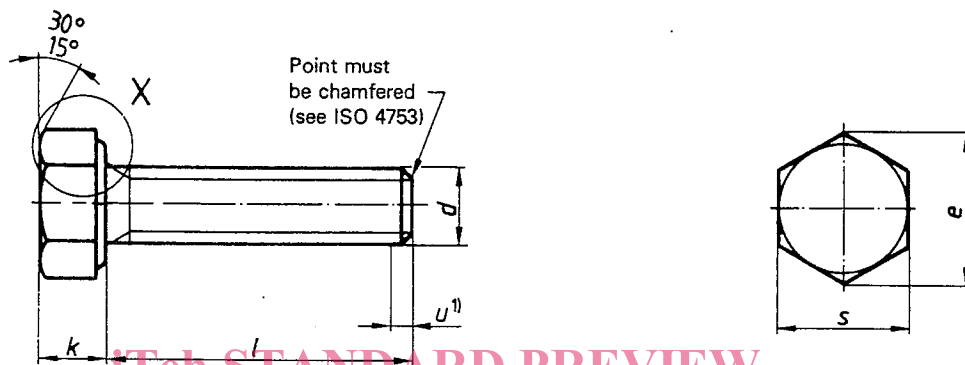

ITeh STANDARD PREVIEW  
(standards.iteh.ai)

SIST EN 28676:1996

<https://standards.iteh.ai/catalog/standards/sist/e1732f41-e8f5-4d18-810d-831ca8b7e143/sist-en-28676-1996>

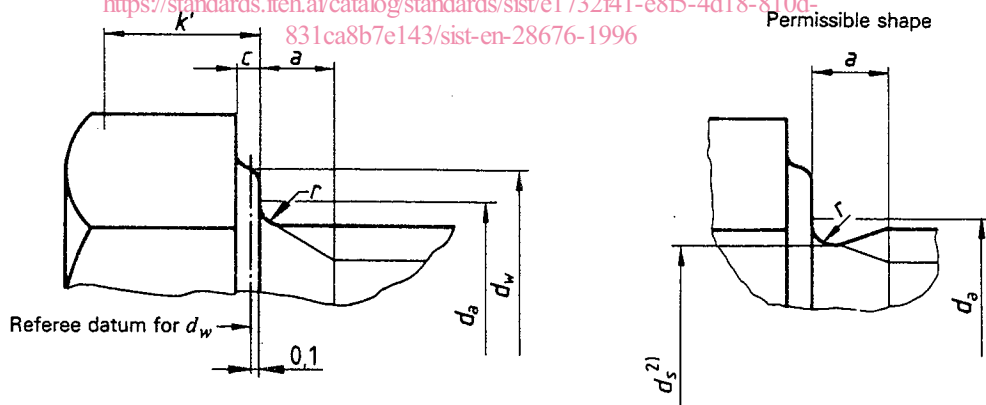

1) Incomplete thread  $u < 2 P$ .

2)  $d_s \approx$  pitch diameter.