



Designation: **D4186—06 D4186/D4186M – 12**

Standard Test Method for One-Dimensional Consolidation Properties of Saturated Cohesive Soils Using Controlled-Strain Loading¹

This standard is issued under the fixed designation **D4186/D4186M**; the number immediately following the designation indicates the year of original adoption or, in the case of revision, the year of last revision. A number in parentheses indicates the year of last reappraisal. A superscript epsilon (ϵ) indicates an editorial change since the last revision or reappraisal.

1. Scope*

1.1 This test method is for the determination of the magnitude and rate-of-consolidation of saturated cohesive soils using continuous controlled-strain axial compression. The specimen is restrained laterally and drained axially to one surface. The axial force and base excess pressure are measured during the deformation process. Controlled strain compression is typically referred to as constant rate-of-strain (CRS) testing.

1.2 This test method provides for the calculation of total and effective axial stresses, and axial strain from the measurement of axial force, axial deformation, chamber pressure, and base excess pressure. The effective stress is computed using steady state equations.

1.3 This test method provides for the calculation of the coefficient of consolidation and the hydraulic conductivity throughout the loading process. These values are also based on steady state equations.

1.4 This test method makes use of steady state equations resulting from a theory formulated under particular assumptions. Section 5.45.5 presents these assumptions.

1.5 The behavior of cohesive soils is strain rate dependent and hence the results of a CRS test are sensitive to the imposed rate of strain. This test method imposes limits on the strain rate to provide comparable results to the incremental consolidation ~~test~~ test (Test Method D2435).

1.6 The determination of the rate and magnitude of consolidation of soil when it is subjected to incremental loading is covered by Test Method D2435.

1.7 This test method applies to intact (Group C and Group D of Practice D4220), remolded, or laboratory reconstituted ~~samples or specimens~~ samples.

1.8 This test method is most often used for materials of relatively low hydraulic conductivity that generate measurable excess base pressures. It may be used to measure the compression behavior of essentially free draining soils but will not provide a measure of the hydraulic conductivity or coefficient of consolidation.

1.9 All recorded and calculated values shall conform to the guide for significant digits and rounding established in Practice D6026, unless superseded by this test method. The significant digits specified throughout this standard are based on the assumption that data will be collected over an axial stress range from 1% of the maximum stress to the maximum stress value.

1.9.1 The procedures used to specify how data are collected/recorded and calculated in this standard are regarded as the industry standard. In addition, they are representative of the significant digits that should generally be retained. The procedures used do not consider material variation, purpose for obtaining the data, special purpose studies, or any considerations for the user's objectives; and it is common practice to increase or reduce significant digits of reported data to be commensurate with these considerations. It is beyond the scope of this standard to consider significant digits used in analysis methods for engineering design.

1.9.2 Measurements made to more significant digits or better sensitivity than specified in this standard shall not be regarded a non-conformance with this standard.

1.10 Units—This standard is written using SI units. Inch-pound units are provided for convenience. The values stated in either SI units or inch-pound units [given in brackets] are to be regarded separately as standard. The values stated in inch-pound units each system may not be exact equivalents; therefore, they each system shall be used independently of the SI system. Other. Combining values from the two systems may result in non-conformance with the this standard.

¹ This test method is under the jurisdiction of ASTM Committee **D18** on Soil and Rock and is the direct responsibility of Subcommittee **D18.05** on Strength and Compressibility of Soils.

Current edition approved ~~Sept. 1, 2006~~ Nov. 1, 2012. Published ~~December 2006~~ December 2012. Originally approved in 1982. Last previous edition approved in ~~1998~~ 2006 as ~~D4186—89 (1998)~~ D4186—06—1. DOI: ~~10.1520/D4186-06-1~~ 10.1520/D4186_D4186M-12.

*A Summary of Changes section appears at the end of this standard



1.10.1 The gravitational system of ~~inch-pound units~~ is used when ~~dealing~~working with inch-pound units. In this system, the pound (lbf) represents a unit of force (weight), while the unit for mass is slugs. The rationalized slug unit is not given, unless dynamic ($F = ma$) calculations are involved.

1.10.2 It is common practice in the engineering/construction profession to concurrently use pounds to represent both a unit of mass (lbm) and of force (lbf). This implicitly combines two separate systems of units; that is, the absolute system and the gravitational system. It is scientifically undesirable to combine the use of two separate sets of inch-pound units within a single standard. As stated, this standard includes the gravitational system of inch-pound units and does not use/present the slug unit for mass. However, the use of balances or scales recording pounds of mass (lbm) or recording density in lbm/ft^3 shall not be regarded as non-conformance with this standard.

1.11 *This standard may involve hazardous materials, operations, and equipment. This standard does not purport to address all of the safety concerns, if any, associated with its use. It is the responsibility of the user of this standard to establish appropriate safety and health practices and determine the applicability of regulatory limitations prior to use.*

2. Referenced Documents

2.1 ASTM Standards:²

[D653 Terminology Relating to Soil, Rock, and Contained Fluids](#)

[D854 Test Methods for Specific Gravity of Soil Solids by Water Pycnometer](#)

[D1587 Practice for Thin-Walled Tube Sampling of Soils for Geotechnical Purposes](#)

[D2216 Test Methods for Laboratory Determination of Water \(Moisture\) Content of Soil and Rock by Mass](#)

[D2435 Test Methods for One-Dimensional Consolidation Properties of Soils Using Incremental Loading](#)

[D2487 Practice for Classification of Soils for Engineering Purposes \(Unified Soil Classification System\)](#)

[D2488 Practice for Description and Identification of Soils \(Visual-Manual Procedure\)](#)

[D3213 Practices for Handling, Storing, and Preparing Soft Intact Marine Soil](#)

[D3550 Practice for Thick Wall, Ring-Lined, Split Barrel, Drive Sampling of Soils](#)

[D3740 Practice for Minimum Requirements for Agencies Engaged in Testing and/or Inspection of Soil and Rock as Used in Engineering Design and Construction](#)

[D4220 Practices for Preserving and Transporting Soil Samples](#)

[D4318 Test Methods for Liquid Limit, Plastic Limit, and Plasticity Index of Soils](#)

[D4452 Practice for X-Ray Radiography of Soil Samples](#)

[D4753 Guide for Evaluating, Selecting, and Specifying Balances and Standard Masses for Use in Soil, Rock, and Construction Materials Testing](#)

[D5720 Practice for Static Calibration of Electronic Transducer-Based Pressure Measurement Systems for Geotechnical Purposes](#)

[D6026 Practice for Using Significant Digits in Geotechnical Data](#)

[D6027 Practice for Calibrating Linear Displacement Transducers for Geotechnical Purposes](#)

[D6519 Practice for Sampling of Soil Using the Hydraulically Operated Stationary Piston Sampler](#)

[D6913 Test Methods for Particle-Size Distribution \(Gradation\) of Soils Using Sieve Analysis](#)

[D7015 Practices for Obtaining Intact Block \(Cubical and Cylindrical\) Samples of Soils](#)

3. Terminology

3.1 Definitions:

3.1.1 For definitions of ~~other~~technical terms used in this Test Method, see Terminology [D653](#).

3.2 Definitions of Terms:

3.2.1 *back pressure, (u_b (FL^{-2}))*—a fluid pressure in excess of atmospheric pressure that is applied to the drainage boundary of a test specimen.

² For referenced ASTM standards, visit the ASTM website, www.astm.org, or contact ASTM Customer Service at service@astm.org. For *Annual Book of ASTM Standards* volume information, refer to the standard's Document Summary page on the ASTM website.

3.2.1.1 Discussion—

Typically, the back pressure is applied to cause air in the pore spaces to pass into solution, thus saturating the specimen.

3.2.2 *consolidometer*—an apparatus containing a specimen under conditions of ~~none~~negligible lateral deformation while allowing one-dimensional axial deformation and one directional axial flow.

3.2.3 *excess pore-water pressure, u (FL^{-2})*—*in effective stress testing*, the pressure that exists in the pore fluid relative to (above or below) the back pressure.

3.2.4 *total axial stress, σ_a (FL^{-2})*—*in effective stress testing*, the ~~total~~normal stress applied to the ~~free draining surface axial boundary~~ of the specimen in excess of the back pressure.



3.3 Definitions of Terms Specific to This Standard:

3.3.1 *axial displacement reading, AD (volts)*—readings taken during the test of the axial displacement transducer.

3.3.2 *axial force reading, AF (volts)*—readings taken during the test of the axial force transducer.

3.3.1 *average effective axial stress, σ_a (FL^{-2})*—the effective stress calculated using either the linear or nonlinear theory equations to represent the average value during at any time under steady state constant strain rate conditions.

3.3.2 *axial deformation reading, AD (volts)*—readings taken during the test of the axial deformation transducer.

3.3.3 *axial force reading, AF (volts)*—readings taken during the test of the axial force transducer.

3.3.4 *base excess pressure, u_m (FL^{-2})*—the fluid pressure in excess (above or below) of the back pressure that is measured at the impervious/sealed boundary of the specimen under conditions of one way drainage. The base excess pressure will be positive during loading and negative during unloading.

3.3.5 *base excess pressure ratio, R_u (D)*—the ratio of (1) the base excess pressure to (2) the total axial stress. This value will be positive during loading and negative during unloading.

3.3.6 *base excess pressure reading, BEP (volts)*—readings taken during the test of the base excess pressure transducer when using a differential pressure transducer which is referenced to the chamber pressure.

3.3.7 *base pressure, u_m (FL^{-2})*—the fluid pressure measured at the impervious/sealed boundary (usually at the base of the consolidometer) of the specimen under conditions of one way drainage.

3.3.8 *base pressure reading, BP (volts)*—readings taken during the test of the base pressure transducer.

3.3.9 *chamber pressure, p_c (FL^{-2})*—the fluid pressure inside the consolidometer. In most CRS consolidometers, the chamber fluid is in direct contact with the specimen. For these devices (and this test method), the chamber pressure will be equal to the back pressure.

3.3.10 *chamber pressure reading, CP (volts)*—readings taken during the test of the chamber pressure transducer.

3.3.11 *constant rate-of-strain, CRS*—a method of consolidating a specimen in which the surface is deformed at a uniform rate while measuring the axial deformation, axial reaction force, and induced base excess pressure.

3.3.12 *dissipation*—change over time of an excess initial condition to a time independent condition.

3.3.13 *equilibrated water*—~~potable~~ test water that has come to equilibrium with the current room conditions including temperature, chemistry, dissolved air, and stress state.

3.3.14 *linear theory (calculation method)*—a set of equations derived based on the assumption that the coefficient of volume compressibility (m_v) is ~~constant~~ constant (the soil follows a linear strain versus effective stress relationship).

3.3.15 *monofilament nylon screen*—thin porous synthetic woven ~~filter~~ fabric made of single untwisted filament nylon.

3.3.16 *nonlinear theory (calculation method)*—a set of equations derived based on the assumption that the compression index (C_c) is ~~constant~~ constant (the soil follows a linear strain versus log effective stress relationship).

3.3.17 *steady state condition—in CRS testing*, a time independent strain distribution within the specimen that changes in average value as loading proceeds.

3.3.18 ~~pore-water pressure~~ *steady state factor, F (D)*—a dimensionless number equal to the change in total axial stress minus the base excess pressure divided by the change in total axial stress.

3.3.16 ~~pore-water pressure~~ *ratio, R_u (D)*—the base excess pressure divided by the total axial stress.

3.3.17 ~~steady state condition—in CRS testing~~, a time independent strain distribution within the specimen that changes in average value as loading proceeds.

3.3.19 *transient condition—in CRS testing*, a time dependent variation in the strain distribution within the specimen that is created at the start of a CRS loading or unloading phase or when the strain rate changes and then decays with time to a steady state strain distribution.

3.3.20 *unit conversion factor*—a constant used in an equation to unify the system of units (eg, SI to inch pound) or prefix of variables (eg. cm to m) within the same system of units.

4. Summary of Test Method

4.1 In this test method the specimen is constrained axially between two parallel, rigid ~~platens~~ boundaries and laterally such that the cross sectional area remains essentially constant. Drainage is provided along one boundary (typically the top) and the fluid pressure is measured at the other sealed boundary (typically the ~~base~~ base) of the consolidometer.

4.2 A back pressure is applied to saturate both the specimen and the base pressure measurement system.

4.3 The specimen is deformed axially at a constant rate while measuring the time, axial deformation, reaction force, chamber pressure, and base pressure. A standard test includes one loading phase, one constant load phase, and one unloading phase. The



constant load phase allows the base excess pressure to return to near zero prior to unloading. More extensive tests can be performed by including more phases to obtain unload-reload cycle(s).

4.4 The rate of deformation is selected to produce a ~~pore-base excess~~ pressure ratio that is between ~~3% and 15%~~ about 3% and 15% at the end of the loading phase.

NOTE 1—The base excess pressure ratio typically decreases during loading. The lower limit provides sufficient pressure to compute the rate parameters and the upper limit reduces the differences between the linear and non linear model calculations. It also helps constrain differences in the compression behavior when testing rate sensitive materials.

4.5 During loading and unloading, the measurements are first evaluated in order to be sure transient effects are ~~small~~ small as defined by the steady state factor. Steady state equations are then used to compute the one-dimensional effective axial stress versus strain relationship. During the loading phase, when base excess pressures are ~~significant~~ significant and transient effects are small, the measurements are used to compute both the coefficient of consolidation and hydraulic conductivity throughout the test.

4.6 It is possible to interpret measurements made during the test when transient effects are significant but these equations are complicated and beyond the scope of this standard test method. Interpretation of transient conditions does not constitute non-conformance of this test method.

5. Significance and Use

5.1 Information concerning magnitude of compression and rate-of-consolidation of soil is essential in the design of earth structures and earth supported structures. The results of this test method may be used to analyze or estimate one-dimensional settlements, rates of settlement associated with the dissipation of excess pore-water pressure, and rates of fluid transport due to hydraulic gradients. This test method does not provide information concerning the rate of secondary compression.

5.2 Strain Rate Effects:

5.2.1 It is recognized that the stress-strain results of consolidation tests are strain rate dependent. Strain rates are limited in this test method by specification of the ~~pore-water pressure ratio~~ acceptable magnitudes of the base excess pressure ratio during the loading phase. This specification provides comparable results to the ~~100% consolidation~~ 100% consolidation (end of primary) compression behavior obtained using Test Method [D2435](#).

5.2.2 Field strain rates vary greatly with time, depth below the loaded area, and radial distance from the loaded area. Field strain rates during consolidation processes are generally much slower than laboratory strain rates and cannot be accurately determined or predicted. For these reasons, it is not practical to replicate the field strain rates with the laboratory test strain rate.

5.3 Temperature Effects:

5.3.1 Temperature affects the rate parameters such as hydraulic conductivity and the coefficient of consolidation. The primary cause of temperature effects is due to the changes in pore fluid viscosity but soil sensitivity may also be important. This test method provides results under room temperature conditions, corrections may be required to account for specific field conditions. Such corrections are beyond the scope of this test method. Special accommodation maybe made to replicate field temperature conditions and still be in conformance with this test method.

5.4 ~~This test method may not be used to measure the properties of partially saturated soils because the method requires the material to be back pressure saturated prior to consolidation.~~ Saturation Effects:

5.4.1 ~~This test method may not be used to measure the properties of partially saturated soils because the method requires the material to be back pressure saturated prior to consolidation.~~

5.5 Test Interpretation Assumptions— The equations used in this test method are based on the following assumptions:

5.5.1 The soil is saturated.

5.5.2 The soil is homogeneous.

5.5.3 The compressibility of the soil particles and water is negligible.

5.5.4 Flow of pore water occurs only in the vertical direction.

5.5.5 Darcy's law for flow through porous media applies.

5.5.6 The ratio of soil hydraulic conductivity to compressibility is constant throughout the specimen during the time interval between individual ~~readings~~ reading sets.

5.5.7 The compressibility of the base excess pressure measurement system is negligible compared to that of the soil.

5.6 Theoretical Solutions:

5.6.1 Solutions for constant rate of strain consolidation are available for both linear and nonlinear soil models.

5.6.1.1 The linear model assumes that the soil has a constant coefficient of volume compressibility (m_v). These equations are presented in [13.4](#).

5.6.1.2 The nonlinear model assumes that the soil has a constant compression index (C_c). These equations are presented in [Appendix XI](#).

NOTE 2—The base excess pressure measured at the boundary of the specimen is assumed equal to the maximum excess pore-water pressure in the specimen. The distribution of excess pore-water pressure throughout the specimen is unknown. Each model predicts a different distribution. As the

magnitude of the base excess pressure increases, the difference between the two model predictions increases. At a base excess pressure ratio of 15 %, the difference in the average effective stress calculation between the two models is about 0.3 %.

5.6.2 The equations for the linear case are used for this test method. This test method limits the ~~maximum~~ time interval between readings and the maximum ~~po~~re-water-base excess pressure ratio to values that yield similar results when using either theory. However, it is more precise to use the model that most closely matches the shape to the compression curve.

5.6.3 The nonlinear equations are presented in **Appendix X1** and their use is not considered a non-conformance with this test method.

5.6.4 The equations used in this test method apply only to steady state conditions. The transient strain distribution at the start of ~~the test~~ a loading or unloading phase is insignificant after the ~~po~~re-water pressure steady state factor (F) exceeds 0.4. Data corresponding to lower ~~po~~re-water pressure steady state factors are not used in this test method.

5.7 This test method may be used to measure the compression behavior of free draining soils. For such materials, the base excess pressure will be zero and it will not be possible to compute the coefficient of consolidation or the hydraulic conductivity. In this case, the average effective axial stress is equal to the total axial stress and the results are independent of model.

5.8 The procedures presented in this test method assume a high permeability porous disk is used in the base pressure measurement system. Use of a low permeability porous disk or high-air entry (> 1 bar) disk will require modification of the equipment specifications and procedures. These modifications are beyond the scope of this test method and are not considered a non-conformance.

NOTE 3—The quality of the results produced by application of this standard is dependent on the competence of the personnel performing it, and the suitability of the equipment and facilities. Agencies that meet the criteria of Practice **D3740** are generally considered capable of competent and objective testing/sampling/inspection/etc. Users of this standard are cautioned that compliance with Practice **D3740** does not in itself assure reliable results. Reliable results depend on many factors; Practice **D3740** provides a means of evaluating some of those factors.

6. Apparatus

6.1 *Overview*—**Fig. 1** presents an overview of the arrangement of components for a device used to perform the constant rate of strain consolidation test. This figure is provided to aid the reader and does not describe any specific device. The figure shows the essential components and one of many possible configurations. Other arrangements meeting the individual component specifications outlined in the following sections are equally acceptable.

6.2 *Electronics*—This test method requires the use of electronic transducers along with the necessary apparatus to energize (power supply) and read (digital ~~voltmeter~~multimeter) these transducers. In addition, automatic data acquisition will be necessary to achieve the required reading frequency.

6.2.1 Transducers are required to measure the base pressure (or base excess pressure), the ~~back~~chamber pressure, the axial deformation, and the axial force. Each transducer must meet the accuracy and capacity requirement specified for the particular measurement. The capacity of the force and pressure transducers will depend on the stiffness of the soil and magnitude of the back pressure.

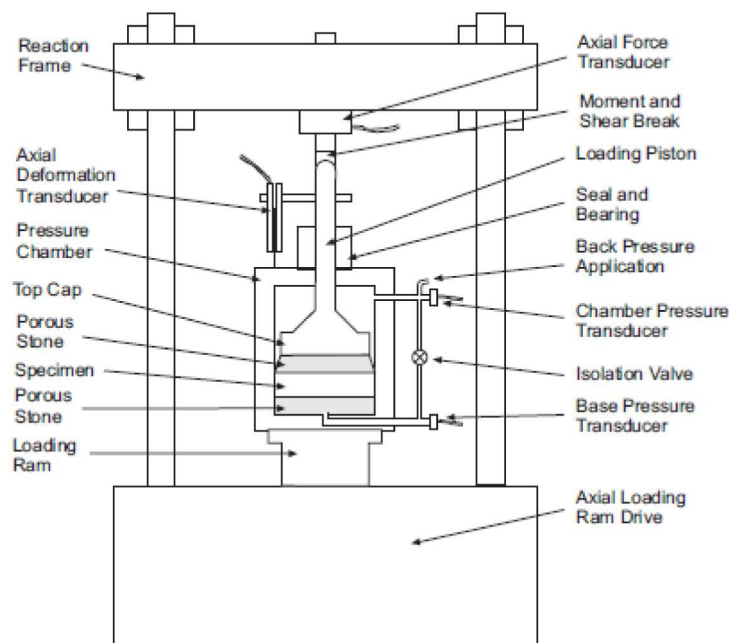

FIG. 1 Overview of Primary Components of a CRS Apparatus



6.2.2 A power supply is required to energize each ~~transducer~~ these transducers. The specific type of power supply will depend on the details of the individual transducers. Ideally, all the transducers will operate using the same power supply. Some data acquisition systems provide transducer power.

6.2.3 The calculations presented in this standard assume that the transducers produce a linear normalized voltage output as a function of the parameter being measured as specified in D5720 and D6027. Many other types of transducers exist and are acceptable options for this standard provided that they meet the accuracy and capacity requirements. These transducers may produce current rather than voltage, have non-linear rather than linear outputs, or may not require normalization to the excitation voltage.

6.2.4 Recording Devices:

6.2.4.1 A digital ~~voltmeter~~ multimeter is useful in setting up tests and obtaining zero readings but ~~the actual~~ conducting a test requires far too many readings (frequency and duration) to be collected manually.

6.2.4.2 A data acquisition system is required to collect and store data during the test. The specifications (bit precision and voltage input range) of the data acquisition system must be matched to the individual transducers in order to obtain the capacity necessary for the individual test and readability requirement for each device. These requirements will depend on the stiffness of the soil, the magnitude of the back pressure, and the output characteristics of the specific transducers.

6.2.4.3 A reading set must contain a measurement of base pressure (or base excess pressure), back chamber pressure, axial force, axial deformation, ~~excitation voltage~~, transducer excitation (if using normalized conversion equations), and elapsed time (or time). Time—When determining the hydraulic conductivity or the coefficient of consolidation, time must be recorded to three significant digits of the reading interval. The interval and the reading set must be completed within 0.1 s if the measurements are made sequentially. The reading interval will depend on the strain rate.

6.3 *Axial Loading Device*—This device may be a screw jack driven by an electric motor through a geared transmission, a hydraulic or pneumatic loading device, or any other compression device with sufficient force and deformation capacity. It must be able to apply a constant rate of deformation as well as maintain a constant force. During a single loading or unloading phase of the test, the deformation rate should be monotonic and should not vary by more than a factor of 5. The rate can gradually change due to the system stiffness but should not have more than $\pm 10\%$ cyclic variation. During a constant load phase of the test, the load must be maintained to $\pm 2\%$ of the target value. Vibration due to the operation of the loading device shall be considered sufficiently small when there are no visible ripples in a glass of water placed on the loading platform when the device is operating at the typical test speed.

6.4 *Axial Load Force Measuring Device*—This device may be a load ring, ~~strain-gage~~ strain-gauge load cell, hydraulic load cell, or any other ~~load-measuring force-measuring~~ device capable of the accuracy prescribed in this paragraph and may be a part of the axial loading device. The axial ~~load-measuring force-measuring~~ device shall be capable of measuring the axial load to 0.1% ~~have an accuracy of 0.25% (or better) of full range and a readability of equivalent to at least 54 significant digits at the maximum load force applied to the specimen.~~

6.4.1 For a constant rate-of-deformation to be transmitted from the axial loading device through the ~~load-measuring force-measuring~~ device, it is important that the ~~load-measuring force-measuring~~ device be relatively stiff. Most electronic load cells are sufficiently stiff, while ~~load~~ proving rings are typically not stiff (that is, they are compressible).

6.5 *Back Chamber Pressure Maintaining Device*—~~A device~~ This device is used to back pressure saturate the specimen and base pressure measuring system. It must be capable of applying and controlling the back chamber pressure to within $\pm 2\%$ ~~$\pm 2\%$~~ of the target back-pressure throughout the test. This device may consist of a single unit or separate units connected to the top and bottom of the specimen. The device may be a pressurized hydraulic system or a partially filled reservoir with a gas/water interface. The bottom drainage lines shall be connected to the bottom drainage valve and shall be designed to minimize dead space in the lines. This valve, when open, shall permit the application of ~~back~~ the chamber pressure to the base of the specimen; when closed, it shall prevent the leakage of water from the specimen base and base pressure measuring device. However, if a high air entry stones are used, stone is used on the non drainage boundary of the specimen, then different means will be required to keep the system saturated.

6.5.1 A pressurized hydraulic system may be activated by deadweight acting on a piston, a gear driven piston with feedback control, a hydraulic regulator, or any other pressure-maintaining device capable of applying and controlling the back chamber pressure within the specifications stated above. The system should be filled with equilibrated ~~potable~~ test water.

6.5.2 A pressure reservoir partially filled with ~~potable~~ test water and having a gas/water interface may be controlled by a precision pressure regulator. As much as practicable, the device should minimize the air diffusion into the ~~back pressure chamber~~ water. All gas/water interfaces should be small in area relative to the ~~area~~ volume of water in the specimen and should be in ~~reservoir and the reservoirs~~ connected to the consolidometer by a length of small diameter tubing. Any water remaining in the reservoir should be flushed out after each test and replenished with equilibrated water.

6.5.3 The bottom drainage valve may be assumed to produce minimum volume change if opening or closing the valve in a closed, saturated pore-water pressure system does not induce a pressure change of greater than 0.71 kPa (± 0.1 lbf/in. [0.1 lbf/in²]). All valves must be capable of withstanding applied pressures without significant leakage.

NOTE 4—Ball valves have been found to provide minimum volume-change characteristics; however, any other type of valve having suitable volume-change characteristics may be used.

6.6 *Back Chamber Pressure Measuring Device*—A pressure transducer arranged to measure the applied back chamber pressure shall have an accuracy of $\pm 0.25\%$ $\pm 0.25\%$ (or better) of full range, a capacity in excess of the applied back chamber pressure, and a readability of equivalent to at least 54 significant digits at the maximum applied axial stress.

6.7 *Base Pressure Measuring Device*—This device can be a differential pressure transducer referenced to the back chamber pressure or a separate pressure transducer measuring pressure at the base of the specimen. If a separate pressure transducer is used, then its zero value must be adjusted to give the same pressure reading as the back chamber pressure transducer at the end of back pressure saturation and with the bottom drainage valve open. The device shall be constructed and located such that the water pressure at the base of the specimen can be measured with negligible drainage from the specimen due to changes in pore-water pressure. To achieve this requirement, a very stiff electronic pressure transducer must be used. The compliance of all the assembled parts of the base pressure measurement system relative to the total volume of the specimen shall satisfy the following requirement:

$$(V/V)/u_m < 3.2 \times 10^{-6} \text{ m}^2/\text{kN} \text{ (} 2.2 \times 10^{-5} \text{ in}^2/\text{lbf)} \quad (1)$$

$$(V/V)/u_m < 3.2 \times 10^{-6} \text{ m}^2/\text{kN} \text{ [} 2.2 \times 10^{-5} \text{ in}^2/\text{lbf]} \quad (1)$$

where:

ΔV = change in volume of the base measurement system due to a pressure change, mm^3 (in^3);

V = total volume of the specimen, mm^3 (in^3), and

u_m = change in base excess pressure, kPa (lbf/in^2).

ΔV = change in volume of the base measurement system due to a pressure change, mm^3 [in^3],

V = total volume of the specimen, mm^3 [in^3], and

u_m = change in base excess pressure, kPa [lbf/in^2].

NOTE 5—To meet this compressibility requirement, tubing between the specimen and the measuring device should be short and thick-walled with small bores. Thermoplastic, copper, and stainless steel tubing have been used successfully.

6.7.1 A differential pressure transducer shall have an accuracy of $\pm 0.25\%$ $\pm 0.25\%$ (or better) of full range, a capacity of at least ~~50%~~ 50% of the maximum applied axial stress, a burst pressure that exceeds the applied back pressure plus ~~50%~~ 50% of the maximum applied axial stress, and a readability of equivalent to at least 54 significant digits at the maximum applied axial stress.

6.7.2 A separate pressure transducer shall have an accuracy of $\pm 0.25\%$ $\pm 0.25\%$ (or better) of full range, a capacity of at least the applied back pressure plus ~~50%~~ 50% of the maximum applied axial stress, and a readability of equivalent to at least 54 significant digits at the maximum applied axial stress.

NOTE 6—Typically, pressure transducers with a capacity of 1500 kPa (200 [200 lbf/in^2]) will meet these requirements.

6.8 *Deformation Measuring Device*—The axial deformation of the specimen is usually determined from the travel of the piston acting on the top platen of the specimen. The deformation measuring device may be a linear variable differential transformer (LVDT), ~~extensometer, a digital dial gauge (DDG), an extensometer, a linear strain transducer (LST),~~ or other electronic measuring device and shall have a range of at least ~~50%~~ 50% of the initial height of the specimen. The device shall have an accuracy of at least 0.25%–0.25% (or better) of full range and a readability of at least 54 significant digits at the initial specimen height.

6.9 *Consolidometer*—This device must hold the specimen in a confinement ring sealed to a rigid base, with porous disks on each face of the specimen and ~~apply contained within a back pressure to the specimen pressure vessel.~~ The pressure vessel must contain the chamber pressure and provide alignment and a pressure seal for the piston. A high air entry stone can be used in place of the porous disk on the bottom of the specimen provided that the high air entry stone is ~~always kept saturated.~~ saturated prior to setting up the specimen. The top platen should be attached to the piston and rigid enough to uniformly distribute the axial load to the top stone. Any potentially submerged parts of the consolidometer shall be made of a material that is noncorrosive in relation to the soil or other parts of the consolidometer. The bottom of the confinement ring shall form a leak proof seal with the rigid base capable of withstanding ~~internal pressures of 1500 kPa (200 lbf/in.~~ the base excess pressure. 2). The consolidometer shall be constructed such that placement of the confinement ring (with specimen) into the consolidometer will not entrap air at the base of the specimen. The axial loading device and back chamber pressure maintaining device may be an integral part of the consolidometer. A schematic drawing of ~~a typical~~ the essential components of a generic CRS consolidometer is shown in Fig. 12.

6.9.1 *Axial Loading Piston*—~~The axial load piston seal must be designed so the variation in axial load due to friction does not exceed 0.05% of the maximum axial load applied to the specimen.~~ loading piston transfers force to the specimen and passes through the pressure vessel.

6.9.1.1 The piston should be constructed of hardened stainless steel with surface roughness and tolerance meeting the specifications set by the bushing manufacturer. The external end of the piston should be concave or convex to mate with the moment break. The internal end should connect rigidly to the top platen.

6.9.1.2 The axial load piston seal must be designed so the variation in axial load due to friction does not exceed 0.05% of the maximum axial load applied to the specimen.

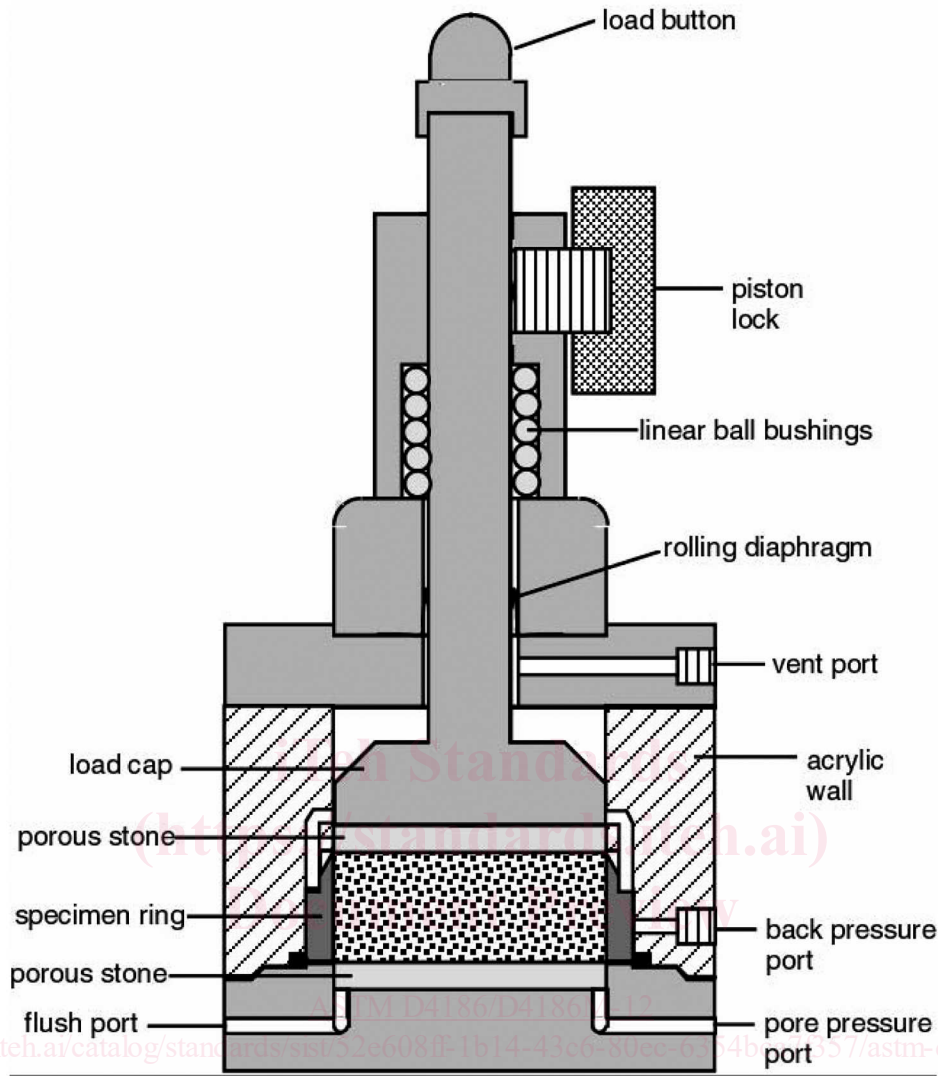

FIG. 42 Example of a CRS Consolidometer

NOTE 7—The use of two linear ball bushings to guide the piston is recommended to minimize friction and maintain alignment.

6.9.1.3 The external end of the piston should be fitted with a shear and moment break. This element allows precise alignment of the loading piston with the load cell while preventing transfer of either a bending moment or lateral force.

6.9.2 *Specimen Confinement Ring*—The confinement ring shall be made of a material that is noncorrosive in relation to the soil and pore fluid. The inner surface shall be polished and coated with a low-friction material (silicone/vacuum grease). The inside diameter of the ring shall be stiff enough to prevent significant lateral deformation of the specimen throughout the test, fabricated to a tolerance of at least 0.1 percent of the diameter.

6.9.2.1 *Ring Rigidity*—The thickness of the ring (for metallic rings) shall be no less than 3.2 mm (ring shall be stiff enough $\frac{1}{8}$ in.) for stresses up to 3000 kPa (400 lbf/in.²) or 6.4 mm (of the specimen throughout $\frac{1}{4}$ in.) for stresses up to 6000 kPa (800 lbf/in.²), such that, under hydrostatic stress conditions in the specimen, the change in diameter of the ring will not exceed 0.04 percent of the diameter under the greatest load applied.

NOTE 8—For example, a ring thickness (for metallic rings) of 3.2 mm [$\frac{1}{8}$ in.] will be adequate for stresses up to 6000 kPa [900 lbf/in.²] for a specimen diameter of 63.5 mm [2.5 in.].

6.9.3 *Specimen Geometry*—The test specimen dimensions shall conform to the following specifications.

6.9.3.1 The minimum diameter shall be about 50 mm (2.0 in.); [2.0 in.].

6.9.3.2 The minimum height shall be about 20 mm (0.75 in.); [0.75 in.], but shall not be less than 10 times the maximum particle diameter as determined in accordance with Test Method D6913. If, after completion of a test, it is found based on visual observation that oversize (> 2 mm; 0.075 in.)mm [0.075 in.] particles are present, indicate this information in the report of test data.



6.9.3.3 The maximum height-to-diameter ratio shall be $0.5-0.4$.

6.10 *Porous Disks*—The porous disks at the top and bottom of the specimen shall be made of silicon carbide, aluminum oxide, or other material of similar stiffness that is not corroded by the specimen or pore fluid. The disks shall have plane and smooth surfaces and be free of cracks, chips, and nonuniformities. They shall be checked regularly to ensure that they are not clogged. For fine-grained soils, fine-grade porous disks shall be used. The disks shall be fine enough that the soil will not penetrate into their pores, but have sufficient hydraulic conductivity so as not to impede the flow of water from the specimen. ~~(Exact criteria have not been established but the disc should be at least 10 times more permeable than the soil.)~~ The disk thickness and hydraulic conductivity should result in an impedance factor of at least 100.

NOTE 9—The impedance factor is defined as the ratio of the hydraulic conductivity of the stones times the drainage thickness of the soil to the hydraulic conductivity of the soil times the thickness of the stone.

6.10.1 The diameter of the top disk shall be 0.2 to 0.5 mm ~~(0.01 to 0.02 in.)~~ in.] less than the inside diameter of the confinement ring.

6.10.2 The surfaces of the disks, as well as the bearing surfaces in contact with them, shall be flat and rigid enough to prevent breakage of these disks.

6.10.3 The disks shall be regularly cleaned by ultrasonification or boiling and brushing and checked routinely for signs of clogging. Disks will last longer if stored in water between testing.

6.11 *Filter Screen—Filtering Element*—To prevent intrusion of material into the pores of the porous disk, a ~~filter screen~~ filtering element must be placed between the top porous disk and the specimen. ~~The screen element~~ shall have negligibly small hydraulic impedance. ~~A fine monofilament-nylon filter-screen or Whatman No. 54 mesh or high grade hardened, low ash filter paper may be used for the top of the specimen.~~ filtering element.

NOTE 10—Filters—Filtering elements should be cut to approximately the same shape as the cross section of the test specimen. Soak the filter paper, if used, in a container of test water to allow it to equilibrate before testing.

6.12 *Balances—Balance*—The ~~balance~~ balance(s) shall be suitable for determining the mass of the specimen ~~and plus the containment ring~~ and for making the water content measurements. ~~The balance(s) shall be selected as discussed in Specification D4753.~~ The mass of specimens shall be determined to at least four significant digits.

6.13 *Sample Extruder*—When the material being tested is contained in a sampling tube, the soil shall be removed from the sampling tube with an extruder. The sample extruder shall be capable of extruding the soil from the sampling tube in the same direction of travel that the soil entered the tube and with minimum disturbance of the soil. If the soil is not extruded vertically, care should be taken to avoid bending stresses on the soil due to gravity. Conditions at the time of soil extrusion may dictate the direction of removal, but the principle concern is to avoid causing further sample disturbance.

NOTE 11—Removing the soil from a short section of the tube will reduce the amount of force required to extrude the sample and hence cause less disturbance. This can be done by cutting a section from the tube with a band saw or tube cutter prior to extrusion. When using a tube cutter it will be necessary to provide additional support to prevent ovalization of the tube. This technique is very effective when combined with radiography to nondestructively examine the soil and select test locations.

6.14 *Specimen Trimming Devices*—A trimming turntable or a cylindrical cutting ring may be used for cutting the cylindrical samples to the proper specimen diameter. The cutting ring may be part of the confinement ring or a separate piece that fits on the confinement ring. The cutter shall have a sharp edge, a highly polished surface, and be coated with a low-friction material. Alternatively, a turntable or trimming lathe may be used. In either case, the cutting tool must be properly aligned to form a specimen of the same or slightly larger diameter as that of the confinement ring. The top and bottom surface of the specimen may be rough trimmed with a wire saw. All flat surfaces must be finish trimmed with a sharpened straight edge and shall have a flatness tolerance of ± 0.05 mm ~~(0.002 in.)~~ [0.002 in.].

6.15 *Recess Spacer*—A disc (usually made of acrylic) used to create a gap between the top of the specimen and the top edge of the confinement ring. The disc should be thick enough to be rigid and larger in diameter than the outside diameter of the confinement ring. One surface of the disc should have a protrusion that is about 0.1 mm ~~(0.005 in.)~~ [0.005 in.] less than the inside diameter of the confinement ring, a ~~thickness~~ step height of at least 1.2 mm ~~(0.050 in.)~~ [0.050 in.] and a flatness tolerance of ± 0.03 mm ~~(0.001 in.)~~ [0.001 in.].

6.16 *Specimen Measuring Device*—The specimen height may be computed from the height of the confinement ring and the recess spacer or measured directly. If applicable, the device to measure the ~~thickness~~ height of the specimen shall be capable of measuring to the nearest 0.01 mm ~~(0.001 in.)~~ [0.001 in.] or better and shall be constructed such that its use will not penetrate the surface of the specimen. The specimen diameter may be assumed equal to the inside diameter of the confinement ring.

6.17 *Temperature Maintaining Device*—~~The temperature of the~~ Unless otherwise specified by the requesting agency, the standard test temperature shall be in the range of $22 \pm 5^\circ\text{C}$. In addition, the temperature of the consolidometer, test specimen, and reservoir of pore fluid shall not vary more than $\pm 3^\circ\text{C}$ ($\pm 6^\circ\text{F}$). ~~2°C .~~ Normally, this is accomplished by performing the test in a room with a relatively constant temperature. If such a room is not available, the apparatus shall be placed in an insulated chamber or other device that maintains a temperature within the tolerance specified above.



6.18 *Test Water*—Water is necessary to saturate the porous stones, fill the pressure chamber and the back pressure system. Ideally, this water would be similar in composition to the specimen pore fluid. Options include extracted pore water from the field, potable tap water, demineralized water, or saline water. The requesting agency should specify the water option. In the absence of a specification, the test should be performed with potable tap water.

6.19 *Water Content Containers*—In accordance with Test Method D2216.

6.20 *Drying Oven*—In accordance with Test Method D2216.

6.21 *Miscellaneous Equipment*—Specimen trimming and carving tools such as spatulas, knives, and wire saws, data sheets, and wax paper or ~~teflon~~-polytetrafluoroethylene (PTFE) sheet as required.

7. Calibration

7.1 Measure diameter (D_r) and height (H_r) of the confinement ring to the nearest 0.01 mm (0.001 in.).

7.2 The cross sectional area (A) of the specimen may be computed from the inside diameter of the consolidometer ring to four significant digits in mm^2 (in.^2).

7.1 *Apparatus Constants*—Apply a thin coat of grease to the inside perimeter and measure the mass of the confinement ring plus the filter screen and the recess spacer (The following information is required to determine the physical characteristics M_r) to the nearest 0.01 g: specimen.

7.1.1 Measure diameter (D_r) and height (H_r) of the confinement ring to the nearest 0.01 mm [0.001 in.].

7.1.2 The cross sectional area (A) of the specimen may be computed from the inside diameter of the confinement ring to four significant digits in cm^2 [in.^2].

7.1.3 Apply a thin coat of grease to the inside perimeter and measure the mass of the confinement ring plus one filtering element and the recess spacer (M_r) to the nearest 0.01 g.

7.1.4 Measure the thickness of the recess spacer plus one filtering element (T_{rs}) to the nearest 0.01 mm [0.001 in.].

7.4 Measure the thickness of the recess spacer plus the filter screen (T_{rs}).

7.2 *Miscellaneous Loading Elements*—The consolidometer deflects due to both changes in cell pressure and axial load, referred to as apparatus compressibility. The apparatus compressibility must be subtracted from the measured deformations in order to correctly compute the specimen axial strain. Determine the cumulative mass (to the nearest 0.001 kg) of the top porous disk plus any other apparatus components that rest on the specimen and are not counterbalanced by the load frame, *strain*: M_a .

7.6 During consolidation, the measured axial displacements shall be corrected for apparatus compressibility whenever the equipment deformation exceeds 0.05 % of the specimen height.

7.6.1 Assemble the apparatus with a copper or steel disk of approximately the same size as the specimen, the filter screen and the porous disks.

7.6.2 Record readings of the axial displacement (AD_n) and axial force (AF_n) as the axial force is increased from the seating value to its maximum value and then returned to the seating value.

7.6.3 Use these data to establish the relationship between apparatus deformation (c_p) as a function of net force (F_n).

7.3 *Consolidometer Deflection*—During back pressure saturation, the measured axial displacement shall be corrected for apparatus compressibility whenever the equipment deformation exceeds 0.05 % of the specimen height. The consolidometer deflects due to both changes in axial load and chamber pressure, referred to as apparatus compressibility. The apparatus compressibility must be subtracted from the measured deformations in order to correctly compute the specimen axial strain.

7.3.1 *Correction due to Axial Load*—Assemble the apparatus with a copper or steel disk of approximately the same size as the specimen, the filter screen and the porous disks. During consolidation, the measured axial deformations shall be corrected for apparatus compressibility whenever the equipment deformation exceeds 0.10 % of the initial specimen height. If the correction is warranted at any point during the test, then it should be applied to all measurements throughout the test.

7.3.1.1 Assemble the apparatus with a copper, steel, or aluminum disk of approximately the same size as the specimen, the filtering element and the porous disks.

7.3.1.2 Record readings of the axial deformation (AD_n) and axial force (AF_n) as the axial force is increased from the seating value to its maximum value and then returned to the seating value.

7.3.1.3 Use these data to establish the relationship between apparatus deformation (c_p) in mm [in.] as a function of net force (F_n) in kN [lbf].

7.3.2 *Correction due to Chamber Pressure*—Apply a seating net force to the calibration disk (During back pressure saturation, the measured axial deformation $F_{a,0}$) prior to applying any chamber pressure and record the axial displacement (shall be corrected for apparatus compressibility whenever the equipment deformation exceeds ΔD 0.10 % of the specimen height. If the correction is warranted at any point during the test, then correction should be applied throughout the test.

7.3.2.1 Assemble the apparatus with a copper, steel, or aluminum disk of approximately the same size as the specimen, the filtering element, and the porous disks.