**Hydraulic fluid power — Dimensions
and requirements of quick-action
couplings, flush-face type**

*Transmissions hydrauliques — Dimensions et exigences des raccords
rapides de type à face plane*

iTeh STANDARD PREVIEW
(standards.iteh.ai)

ISO 16028:2023

<https://standards.iteh.ai/catalog/standards/sist/95621111-0690-4c0c-9de7-082bfa3bb1c3/iso-16028-2023>



iTeh STANDARD PREVIEW
(standards.iteh.ai)

ISO 16028:2023

<https://standards.iteh.ai/catalog/standards/sist/95621111-0690-4c0c-9de7-082bfa3bb1c3/iso-16028-2023>



COPYRIGHT PROTECTED DOCUMENT

© ISO 2023

All rights reserved. Unless otherwise specified, or required in the context of its implementation, no part of this publication may be reproduced or utilized otherwise in any form or by any means, electronic or mechanical, including photocopying, or posting on the internet or an intranet, without prior written permission. Permission can be requested from either ISO at the address below or ISO's member body in the country of the requester.

ISO copyright office
CP 401 • Ch. de Blandonnet 8
CH-1214 Vernier, Geneva
Phone: +41 22 749 01 11
Email: copyright@iso.org
Website: www.iso.org

Published in Switzerland

Contents

	Page
Foreword.....	iv
Introduction.....	v
1 Scope.....	1
2 Normative references.....	1
3 Terms and definitions.....	1
4 Dimensional requirements.....	1
5 Performance requirements.....	4
6 Marking.....	4
7 Identification statement (Reference to this document).....	4
Bibliography.....	6

iTeh STANDARD PREVIEW (standards.iteh.ai)

ISO 16028:2023

<https://standards.iteh.ai/catalog/standards/sist/95621111-0690-4c0c-9de7-082bfa3bb1c3/iso-16028-2023>

Foreword

ISO (the International Organization for Standardization) is a worldwide federation of national standards bodies (ISO member bodies). The work of preparing International Standards is normally carried out through ISO technical committees. Each member body interested in a subject for which a technical committee has been established has the right to be represented on that committee. International organizations, governmental and non-governmental, in liaison with ISO, also take part in the work. ISO collaborates closely with the International Electrotechnical Commission (IEC) on all matters of electrotechnical standardization.

The procedures used to develop this document and those intended for its further maintenance are described in the ISO/IEC Directives, Part 1. In particular, the different approval criteria needed for the different types of ISO documents should be noted. This document was drafted in accordance with the editorial rules of the ISO/IEC Directives, Part 2 (see www.iso.org/directives).

Attention is drawn to the possibility that some of the elements of this document may be the subject of patent rights. ISO shall not be held responsible for identifying any or all such patent rights. Details of any patent rights identified during the development of the document will be in the Introduction and/or on the ISO list of patent declarations received (see www.iso.org/patents).

Any trade name used in this document is information given for the convenience of users and does not constitute an endorsement.

For an explanation of the voluntary nature of standards, the meaning of ISO specific terms and expressions related to conformity assessment, as well as information about ISO's adherence to the World Trade Organization (WTO) principles in the Technical Barriers to Trade (TBT), see www.iso.org/iso/foreword.html.

This document was prepared by Technical Committee ISO/TC 131, *Fluid power systems*, Subcommittee SC 4, *Connectors and similar products and components*.

This second edition cancels and replaces the first edition (ISO 16028:1999), which has been technically revised. It also incorporates the Amendment ISO 16028:1999/Amd.1:2006.

The main changes are as follows:

- the normative references ([Clause 2](#)) have been updated;
- size 31,5, size 38 and size 51 have been added to [Table 1](#) and [Table 2](#);
- [Figure 1](#) has been updated;
- the performance requirements have been updated ([5.2](#) to [5.6](#));
- a new [Clause 6](#), Marking, has been added;
- the title of ISO 16028 has been deleted from the identification statement ([Clause 7](#)).

Any feedback or questions on this document should be directed to the user's national standards body. A complete listing of these bodies can be found at www.iso.org/members.html.

Introduction

In hydraulic fluid power systems, power is transmitted and controlled through a liquid under pressure within an enclosed circuit. Quick-action couplings are used to quickly join or separate fluid conductor lines, without the use of tools or special devices.

iTeh STANDARD PREVIEW
(standards.iteh.ai)

ISO 16028:2023

<https://standards.iteh.ai/catalog/standards/sist/95621111-0690-4c0c-9de7-082bfa3bb1c3/iso-16028-2023>

Hydraulic fluid power — Dimensions and requirements of quick-action couplings, flush-face type

1 Scope

This document specifies the interface dimensions for interchangeability and specifies the performance requirements for hydraulic quick-action couplings, flush-face type, for use at pressures of 10 MPa (100 bar) to 31,5 MPa (315 bar), depending upon the coupling size.

Couplings in accordance with this document are not designed to connect or disconnect under pressure.

Couplings in accordance with this document provide for automatic sealing of the fluid pressure on the upstream side and on the downstream side when the coupling is disconnected.

2 Normative references

The following documents are referred to in the text in such a way that some or all of their content constitutes requirements of this document. For dated references, only the edition cited applies. For undated references, the latest edition of the referenced document (including any amendments) applies.

ISO 5598, *Fluid power systems and components — Vocabulary*

ISO 6803, *Rubber or plastics hoses and hose assemblies — Hydraulic-pressure impulse test without flexing*

ISO 18869, *Hydraulic fluid power — Test methods for couplings actuated with or without tools*

3 Terms and definitions

For the purposes of this document, the terms and definitions given in ISO 5598 apply.

ISO and IEC maintain terminology databases for use in standardization at the following addresses:

- ISO Online browsing platform: available at <https://www.iso.org/obp>
- IEC Electropedia: available at <https://www.electropedia.org/>

4 Dimensional requirements

Hydraulic flush-face quick-action couplings shall conform to the dimensions shown in [Figure 1](#) and given in [Table 1](#). The coupling size relates to the nominal inside diameter of the hose, in accordance with ISO 4397, that is recommended for use with the coupling.

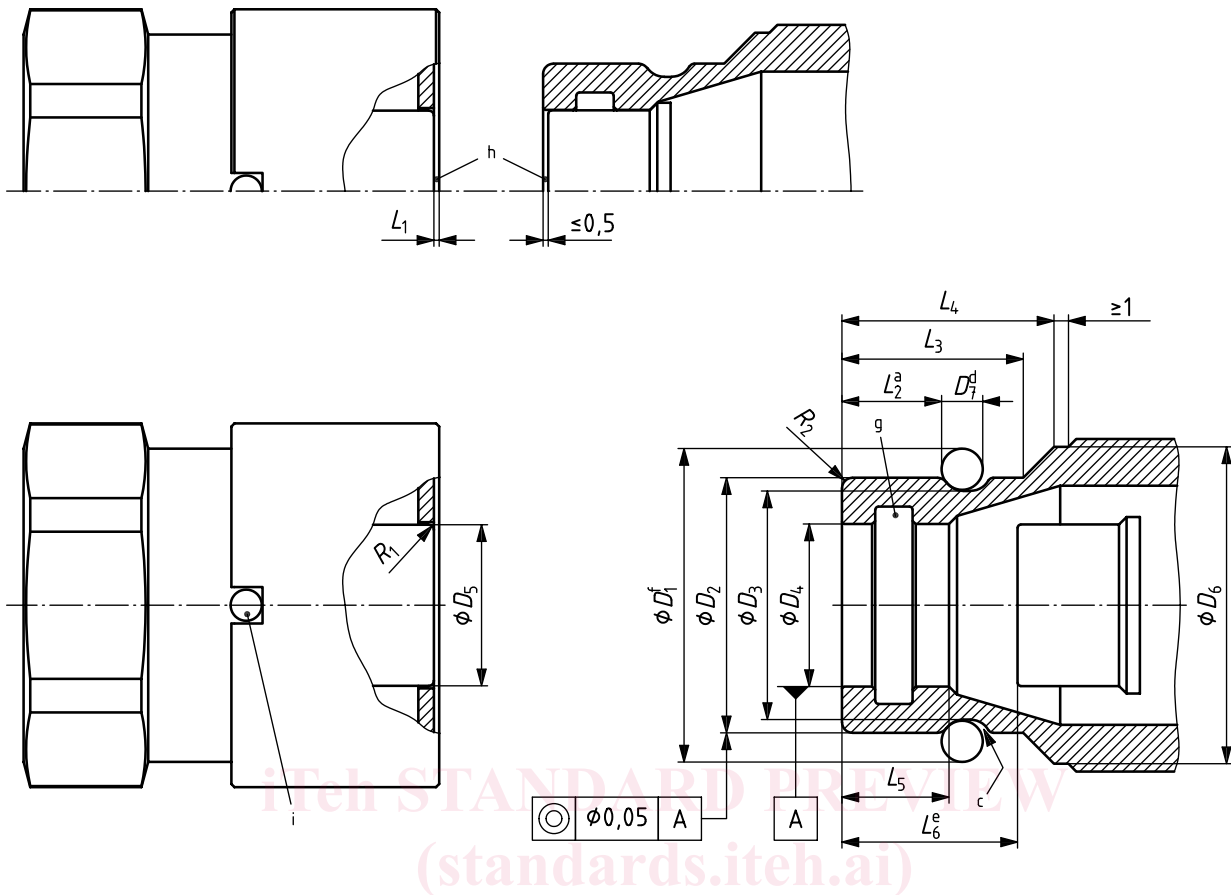

- a Dimension L_2 is measured to the ball.
- b Minimum hardness 50 HRC in ball contact area. See ISO 6508-1.
- c The shape of the neck receiving the balls in the coupled position is left to the manufacturer.
- d Dimension $\varnothing D_7$ is the diameter of the gauge ball.
- e Minimum with poppet against its stop.
- f Dimension $\varnothing D_1$ is the gauge diameter.
- g Locate seal within length L_5 to seal on $\varnothing D_5$.
- h This surface shall be flush within L_1 respectively within the stated measure.
- i Locking collar optional (see 5.7).

Figure 1 — Hydraulic, flush-face type, quick-action coupling

Table 1 — Dimensions for hydraulic, flush-face type, quick-action couplings

Dimensions in millimetres

Size ^a	D ₁		D ₂		D ₃		D ₄		D ₅		D ₆		D ₇		L ₁		L ₂		L ₃		L ₄		L ₅		L ₆		Radius R ₁		Radius R ₂ ^b				
	min.	max.	min.	max.	min.	max.	min.	max.	min.	max.	min.	max.	min.	max.	±	max.	0,0025	max.	min.	max.	min.	max.	min.	max.	min.	max.	min.	max.	min.	max.			
6,3	20,50	16,10	16,20	13,85	14,05	9,70	9,75	20,70	20,80	3,175	0,60	5,70	5,80	11,56	13,85	13,95	7,65	10,80	0,18	0,33	0,25	0,75											
10	24,10	19,66	19,79	17,53	17,73	12,65	12,70	23,24	23,34	3,175	0,60	4,68	4,86	16,25	18,11	18,21	9,65	15,60	0,25	0,41	0,25	1,15											
12,5	30,15	24,45	24,58	21,90	22,10	15,62	15,70	30,40	30,50	3,969	0,70	9,75	9,95	17,35	20,30	20,40	10,40	16,90	0,25	0,41	0,5	1											
16	32,65	26,95	27,08	24,40	24,60	17,62	17,70	32,90	33,00	3,969	0,70	9,75	9,95	17,35	20,30	20,40	10,50	17,50	0,30	0,46	0,5	1											
19	36,68	29,87	30,00	26,80	27,00	20,67	20,75	38,00	38,10	4,7625	0,90	11,30	11,50	23,20	27,30	27,40	11,25	21,50	0,30	0,46	0,5	1											
25	44,85	35,94	36,07	31,90	32,10	23,67	23,75	45,25	45,35	6,350	1,10	10,80	11,00	23,20	29,85	29,95	13,05	22,60	0,43	0,58	0,75	1,25											
31,5	53,00	43,95	44,05	39,90	40,1	30,65	30,75	53,95	54,05	6,350	1,10	8,30	8,50	24,50	29,45	29,55	11,90	22,50	0,40	0,60	0,75	1,25											
38	67,20	56,95	57,05	52,30	52,50	39,65	39,75	66,50	66,60	7,144	1,60	8,95	9,15	30,50	33,50	33,60	12,00	27,60	0,60	0,80	0,75	1,25											
51	82,30	72,90	73,00	67,60	67,80	50,10	50,20	83,40	83,50	7,144	7,00	13,20	13,40	40,50	45,70	45,90	15,00	32,50	0,65	0,85	1,20	1,70											

^a The size designation corresponds to the nominal size of the hose recommended for use with the coupling, see ISO 4397.

^b Radius or chamfer length.

5 Performance requirements

5.1 Hydraulic, flush-face, quick-action couplings in accordance with this document shall meet or exceed the performance requirements given in [Table 2](#).

5.2 The rated pressure shall be verified by pressure impulse testing in accordance with ISO 6803 as required in ISO 18869 for 1 000 000 cycles in the coupled condition and 100 000 cycles in the uncoupled condition. For the test in the coupled condition the flush-face, quick-action couplings shall be assembled between the test apparatus and an appropriate hose assembly. The nominal diameter of the hose assemblies shall not exceed one size smaller or larger than the quick-action coupling size. See ISO 4397. The rated pressure of the hose assemblies shall be equal or higher than the rated pressure of the quick-action couplings.

5.3 The minimum burst pressure shall be verified by burst pressure testing conducted in accordance with ISO 18869 in the coupled and uncoupled condition.

5.4 The maximum pressure drop at rated flow shall be verified by pressure drop testing conducted in accordance with ISO 18869.

5.5 The fluid loss per disconnect shall be verified by spillage testing conducted in accordance with ISO 18869.

5.6 The flow rate surge shall be verified by long duration surge flow testing for all sizes and short duration surge flow testing up to and including size 25 conducted in accordance with ISO 18869.

5.7 Provisions for locking the coupling in the coupled condition, to reduce the probability of accidental disconnect, shall be agreed upon between the manufacturer and the user.

6 Marking

Couplings conforming to this document shall be permanently marked at a minimum with the manufacturer's name, logo, or product identification.

7 Identification statement (Reference to this document)

Use the following statement in test reports, catalogues and sales literature when electing to conform with this document:

"Dimensional and performance requirements in accordance with ISO 16028:2023"