



SLOVENSKI STANDARD

SIST EN 27436:2002

01-september-2002

BUj c' b] ' nUj] ' n' nUf Ync '] b ' _cb] bc ' n' cVfc Ughja ' fYn] ca ' fIGC ' +(' * .% , ' Ł

Slotted set screws with cup point (ISO 7436:1983)

Gewindestifte mit Schlitz und Ringschneide (ISO 7436:1983)

Vis sans tete, fendues, a bout cuvette (ISO 7436:1983)

Ta slovenski standard je istoveten z: EN 27436:1992

[SIST EN 27436:2002](https://standards.iteh.ai/catalog/standards/sist/67c88823-0fce-44ff-ba3b-0fa1ac621d54/sist-en-27436-2002)

<https://standards.iteh.ai/catalog/standards/sist/67c88823-0fce-44ff-ba3b-0fa1ac621d54/sist-en-27436-2002>

ICS:

21.060.10 Sorniki, vijaki, stebelni vijaki Bolts, screws, studs

SIST EN 27436:2002

en

iTeh STANDARD PREVIEW
(standards.iteh.ai)

[SIST EN 27436:2002](#)

<https://standards.iteh.ai/catalog/standards/sist/67c88823-0fce-44ff-ba3b-0fa1ac621d54/sist-en-27436-2002>

EUROPEAN STANDARD

EN 27436:1992

NORME EUROPÉENNE

EUROPÄISCHE NORM

July 1992

UDC 621.882.219.71.092.6

Descriptors: Fasteners, screws, set screws, specifications, dimensions, designation

English version

Slotted set screws with cup point (ISO 7436:1983)

Vis sans tête, fendues, à bout cuvette (ISO 7436:1983)

Gewindestifte mit Schlitz und Ringschneide (ISO 7436:1983)

iTeh STANDARD PREVIEW
(standards.iteh.ai)

SIST EN 27436:2002

<https://standards.iteh.ai/catalog/standards/sist/67c88823-0fce-44ff-ba3b-0fa1ac621d54/sist-en-27436-2002>

This European Standard was approved by CEN on 1992-07-17. CEN members are bound to comply with the CEN/CENELEC Internal Regulations which stipulate the conditions for giving this European Standard the status of a national standard without any alteration.

Up-to-date lists and bibliographical references concerning such national standards may be obtained on application to the Central Secretariat or to any CEN member.

The European Standards exist in three official versions (English, French, German). A version in any other language made by translation under the responsibility of a CEN member into its own language and notified to the Central Secretariat has the same status as the official versions.

CEN members are the national standards bodies of Austria, Belgium, Denmark, Finland, France, Germany, Greece, Iceland, Ireland, Italy, Luxembourg, Netherlands, Norway, Portugal, Spain, Sweden, Switzerland and United Kingdom.

CEN

European Committee for Standardization
Comité Européen de Normalisation
Europäisches Komitee für Normung

Central Secretariat: rue de Stassart, 36 B-1050 Brussels

FOREWORD

In 1992, CEN Technical Committee CEN/TC 185 "Threaded and non threaded mechanical fasteners and accessories" the secretariat of which is held by DIN decided to submit the International Standard

ISO 7436:1983 - "Slotted set screws with cup point"

to the formal vote procedure.

The result was positive.

In the countries bound to implement this European Standard a national standard identical to this European standard shall be published at the latest by 1993-01-31 and conflicting national standards shall be withdrawn at the latest by 1993-01-31.

iTeh STANDARD PREVIEW

According to the CEN/CENELEC Common Rules the following countries are bound to implement this European Standard : Austria, Belgium, Denmark, Finland, France, Germany, Greece, Iceland, Ireland, Italy, Luxembourg, Netherlands, Norway, Spain, Portugal, Sweden, Switzerland and United Kingdom.

<https://standards.iteh.ai/catalog/standards/sist/67c88823-0fce-44ff-ba3b-0fa1ac621d54/sist-en-27436-2002>

Endorsement notice

The text of the International Standard ISO 7436:1983 was approved by CEN as a European Standard without any modification.

International Standard



7436

INTERNATIONAL ORGANIZATION FOR STANDARDIZATION • МЕЖДУНАРОДНАЯ ОРГАНИЗАЦИЯ ПО СТАНДАРТИЗАЦИИ • ORGANISATION INTERNATIONALE DE NORMALISATION

Slotted set screws with cup point

Vis sans tête, fendues, à bout cuvette

First edition — 1983-09-01

iTeh STANDARD PREVIEW
(standards.iteh.ai)

[SIST EN 27436:2002](#)

<https://standards.iteh.ai/catalog/standards/sist/67c88823-0fce-44ff-ba3b-0fa1ac621d54/sist-en-27436-2002>

UDC 621.882.219.4.092.6

Ref. No. ISO 7436-1983 (E)

Descriptors : fasteners, screws, slotted headless screws, dimensions, specifications, designation.

Foreword

ISO (the International Organization for Standardization) is a worldwide federation of national standards bodies (ISO member bodies). The work of developing International Standards is carried out through ISO technical committees. Every member body interested in a subject for which a technical committee has been authorized has the right to be represented on that committee. International organizations, governmental and non-governmental, in liaison with ISO, also take part in the work.

Draft International Standards adopted by the technical committees are circulated to the member bodies for approval before their acceptance as International Standards by the ISO Council.

iTeh STANDARD PREVIEW

International Standard ISO 7436 was developed by Technical Committee ISO/TC 2, *Fasteners*, and was circulated to the member bodies in December 1981. (standards.iteh.ai)

It has been approved by the member bodies of the following countries: <https://standards.iteh.ai/catalog/standards/sist/67c88823-0fce-44ff-ba3b-0fa1ac621c74/sist-en-27436-2002>

Austria	Hungary	Poland
Belgium	India	Romania
Brazil	Ireland	South Africa, Rep. of
China	Japan	Spain
Czechoslovakia	Korea, Dem. P. Rep. of	Sri Lanka
Denmark	Korea, Rep. of	Sweden
Egypt, Arab Rep. of	Mexico	Switzerland
Finland	Netherlands	United Kingdom
France	New Zealand	USSR
Germany, F.R.	Norway	

No member body expressed disapproval of the document.

Slotted set screws with cup point

iTeh STANDARD PREVIEW (standards.iteh.ai)

1 Scope and field of application

This International Standard specifies the characteristics of slotted set screws with cup point and thread sizes from M 1,6 to M 12 inclusive and product grade A.

If other specifications are required, it is recommended that they should be selected from existing International Standards, for example ISO 261, ISO 888, ISO 898, ISO 965, ISO 3506, ISO 4759/1.

2 References

ISO 225, *Fasteners — Bolts, screws, studs and nuts — Symbols and designations of dimensions.*

ISO 261, *ISO general purpose metric screw threads — General plan.*

ISO 888, *Bolts, screws and studs — Nominal lengths, and thread lengths for general purpose bolts.*

ISO 898, *Mechanical properties of fasteners.*

ISO 965, *ISO general purpose metric screw threads — Tolerances.*

ISO 3269, *Fasteners — Acceptance inspection.*¹⁾

ISO 3506, *Corrosion-resistant stainless steel fasteners — Specifications.*

ISO 4042, *Threaded components — Electroplated coatings components.*¹⁾

ISO 4753, *Fasteners — Ends of parts with external metric ISO thread.*

ISO 4759/1, *Tolerances for fasteners — Part 1: Bolts, screws and nuts with thread diameters > 1,6 and < 150 mm and product grades A, B and C.*

1) At present at the stage of draft.

ISO 7436-1983 (E)

3 Dimensions

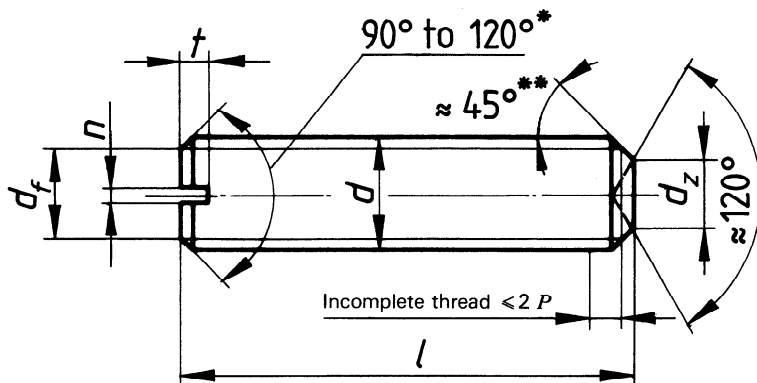

* The 120° angle is mandatory for short length screws above the dotted stepped line.

** The 45° angle applies only to the portion of the point below the root diameter of the thread.

Dimensions in millimetres

Thread size <i>d</i>	M 1,6	M 2	M 2,5	M 3	(M 3,5) ¹⁾	M 4	M 5	M 6	M 8	M 10	M 12	
<i>p</i> ²⁾	0,35	0,4	0,45	0,5	0,6	0,7	0,8	1	1,25	1,5	1,75	
<i>d_f</i>	Minor thread diameter											
<i>d_z</i>	min.	0,55	0,75	0,95	1,15	1,45	1,75	2,25	2,75	4,7	5,7	7,7
	max.	0,8	1	1,2	1,4	1,7	2	2,5	3	5	6	8
<i>n</i>	nom.	0,25	0,25	0,4	0,4	0,5	0,6	0,8	1	1,2	1,6	2
	min.	0,31	0,31	0,46	0,46	0,56	0,66	0,86	1,06	1,26	1,66	2,06
	max.	0,45	0,45	0,6	0,6	0,7	0,8	1	1,2	1,51	1,91	2,31
<i>t</i>	min.	0,56	0,64	0,72	0,8	0,96	1,12	1,28	1,6	2	2,4	2,8
	max.	0,74	0,84	0,95	1,05	1,21	1,42	1,63	2	2,5	3	3,6
SIST EN 27436:2002 https://standards.itech.ai/catalog/standards/sist/67c88823-0fce-44ff-ba3b-0fa1ac621d54/sist-en-27436-2002												
(1), 3)												
nom.	min.	max.										
2	1,8	2,2										
2,5	2,3	2,7										
3	2,8	3,2										
4	3,7	4,3										
5	4,7	5,3										
6	5,7	6,3										
8	7,7	8,3										
10	9,7	10,3	Range									
12	11,6	12,4	of									
(14)	13,6	14,4	commercial									
16	15,6	16,4	lengths									
20	19,6	20,4										
25	24,6	25,4										
30	29,6	30,4										
35	34,5	35,5										
40	39,5	40,5										
45	44,5	45,5										
50	49,5	50,5										
55	54,4	55,6										
60	59,4	60,6										

- 1) Sizes in brackets should be avoided if possible.
- 2) *P* = pitch of the thread.
- 3) Min. and max. values according to ISO 4759/1, but rounded to one decimal place.