



FINAL DRAFT International Standard

ISO/FDIS 6626-2

Internal combustion engines — Piston rings —

Part 2: Coil-spring-loaded oil control rings of narrow width made of cast iron

Moteurs à combustion interne — Segments de piston —

*Partie 2: Segments racleurs régulateurs d'huile étroits, en fonte,
mis en charge par ressort hélicoïdal*

[ISO/FDIS 6626-2](https://standards.iteh.ai/catalog/standards/iso/b630565a-351f-4eb6-8a52-f77a74c4db79/iso-fdis-6626-2)

<https://standards.iteh.ai/catalog/standards/iso/b630565a-351f-4eb6-8a52-f77a74c4db79/iso-fdis-6626-2>

ISO/TC 22/SC 34

Secretariat: ANSI

Voting begins on:
2024-02-27

Voting terminates on:
2024-04-23

RECIPIENTS OF THIS DRAFT ARE INVITED TO SUBMIT, WITH THEIR COMMENTS, NOTIFICATION OF ANY RELEVANT PATENT RIGHTS OF WHICH THEY ARE AWARE AND TO PROVIDE SUPPORTING DOCUMENTATION.

IN ADDITION TO THEIR EVALUATION AS BEING ACCEPTABLE FOR INDUSTRIAL, TECHNOLOGICAL, COMMERCIAL AND USER PURPOSES, DRAFT INTERNATIONAL STANDARDS MAY ON OCCASION HAVE TO BE CONSIDERED IN THE LIGHT OF THEIR POTENTIAL TO BECOME STANDARDS TO WHICH REFERENCE MAY BE MADE IN NATIONAL REGULATIONS.

iTeh Standards
(<https://standards.iteh.ai>)
Document Preview

[ISO/FDIS 6626-2](https://standards.iteh.ai/catalog/standards/iso/b630565a-351f-4eb6-8a52-f77a74e4db79/iso-fdis-6626-2)

<https://standards.iteh.ai/catalog/standards/iso/b630565a-351f-4eb6-8a52-f77a74e4db79/iso-fdis-6626-2>



COPYRIGHT PROTECTED DOCUMENT

© ISO 2024

All rights reserved. Unless otherwise specified, or required in the context of its implementation, no part of this publication may be reproduced or utilized otherwise in any form or by any means, electronic or mechanical, including photocopying, or posting on the internet or an intranet, without prior written permission. Permission can be requested from either ISO at the address below or ISO's member body in the country of the requester.

ISO copyright office
CP 401 • Ch. de Blandonnet 8
CH-1214 Vernier, Geneva
Phone: +41 22 749 01 11
Email: copyright@iso.org
Website: www.iso.org

Published in Switzerland

Contents

Page

Foreword	v
Introduction	vi
1 Scope	1
2 Normative references	1
3 Terms and definitions	1
4 Overview	1
5 Piston ring types and designation	2
5.1 Types DFS-C, DFS-CNP, SSF, GSF, DSF, DSF-NG, and SSF-L — General features and dimensions.....	2
5.2 Type DSF-C — Coil-spring loaded bevelled edge oil control ring, chromium plated and profile ground.....	2
5.2.1 General features and dimensions.....	2
5.2.2 Designation of a Type DSF-C piston ring in accordance with ISO 6626-2.....	3
5.3 Type DSF-CNP — Coil-spring loaded bevelled edge oil control ring, chromium plated not profile ground.....	4
5.3.1 General features and dimensions.....	4
5.3.2 Designation of a Type DSF-CNP piston ring in accordance with ISO 6626-2.....	4
5.4 Type SSF — Coil-spring loaded slotted oil control ring.....	5
5.4.1 General features and dimensions.....	5
5.4.2 Designation of a Type SSF piston ring in accordance with ISO 6626-2.....	5
5.5 Type GSF — Coil-spring loaded double bevelled oil control ring.....	5
5.5.1 General features and dimensions.....	5
5.5.2 Designation of a Type GSF piston ring in accordance with ISO 6626-2.....	6
5.6 Type DSF — Coil-spring loaded bevelled edge oil control ring.....	6
5.6.1 General features and dimensions.....	6
5.6.2 Designation of a Type DSF piston ring in accordance with ISO 6626-2.....	7
5.7 Type DSF-NG — Coil-spring loaded bevelled edge oil control ring (face geometry similar to type DSF-C or type DSF-CNP).....	7
5.7.1 General features and dimensions.....	7
5.7.2 Designation of a Type DSF-NG piston ring in accordance with ISO 6626-2.....	8
5.8 Type SSF-L — Coil-spring loaded slotted oil control ring with 0,4 mm nominal land width.....	8
5.8.1 General features and dimensions.....	8
5.8.2 Designation of a Type SSF-L piston ring in accordance with ISO 6626-2.....	9
6 Common features	9
6.1 Oil drainage by slots or holes.....	9
6.1.1 Arrangement of slots.....	9
6.1.2 Slot length.....	11
6.1.3 Arrangement of holes.....	11
6.1.4 Diameter and number of holes.....	11
6.2 Plating thickness — DSF-C and DSF-CNP (coil-spring loaded bevelled edge oil control ring, chromium plated).....	11
6.3 Peripheral edges at gap of chromium plated oil control rings.....	12
6.4 Spring groove, slot, and land offsets.....	12
7 Coil springs	12
7.1 Types of coil spring.....	12
7.2 Latch pin and location of small pitch in the coil spring.....	14
7.3 Coil spring excursion (extended gap).....	14
7.4 Position of coil spring gap and fixing.....	15
7.5 Material.....	15
8 Tangential force and nominal contact pressure	15
8.1 Tangential force, F_t	15
8.1.1 Force factors.....	15

ISO/FDIS 6626-2:2024(en)

8.1.2	General tangential force, F_t	15
8.1.3	Actual tangential force, F_{tv} , and tolerance.....	16
8.1.4	Normalized tangential force, F_N	16
8.2	Nominal contact pressure, p_0	16
9	Dimensions	16
	Bibliography	31

iTeh Standards (<https://standards.iteh.ai>) Document Preview

[ISO/FDIS 6626-2](https://standards.iteh.ai/catalog/standards/iso/b630565a-351f-4eb6-8a52-f77a74e4db79/iso-fdis-6626-2)

<https://standards.iteh.ai/catalog/standards/iso/b630565a-351f-4eb6-8a52-f77a74e4db79/iso-fdis-6626-2>

Foreword

ISO (the International Organization for Standardization) is a worldwide federation of national standards bodies (ISO member bodies). The work of preparing International Standards is normally carried out through ISO technical committees. Each member body interested in a subject for which a technical committee has been established has the right to be represented on that committee. International organizations, governmental and non-governmental, in liaison with ISO, also take part in the work. ISO collaborates closely with the International Electrotechnical Commission (IEC) on all matters of electrotechnical standardization.

The procedures used to develop this document and those intended for its further maintenance are described in the ISO/IEC Directives, Part 1. In particular, the different approval criteria needed for the different types of ISO documents should be noted. This document was drafted in accordance with the editorial rules of the ISO/IEC Directives, Part 2 (see www.iso.org/directives).

ISO draws attention to the possibility that the implementation of this document may involve the use of (a) patent(s). ISO takes no position concerning the evidence, validity or applicability of any claimed patent rights in respect thereof. As of the date of publication of this document, ISO had received notice of (a) patent(s) which may be required to implement this document. However, implementers are cautioned that this may not represent the latest information, which may be obtained from the patent database available at www.iso.org/patents. ISO shall not be held responsible for identifying any or all such patent rights.

Any trade name used in this document is information given for the convenience of users and does not constitute an endorsement.

For an explanation of the voluntary nature of standards, the meaning of ISO specific terms and expressions related to conformity assessment, as well as information about ISO's adherence to the World Trade Organization (WTO) principles in the Technical Barriers to Trade (TBT), see www.iso.org/iso/foreword.html.

This document was prepared by Technical Committee ISO/TC 22, *Road vehicles*, Subcommittee SC 34, *Propulsion, powertrain and powertrain fluids*.

This third edition cancels and replaces the second edition (ISO 6626-2:2013), which has been technically revised.

The main changes are as follows:

- classes of nominal contact pressure moved to ISO 6626-1:2024, Annex A and introduced normalized tangential force;
- verification and correction of figures;
- update of dimension in [Tables 8](#) to [16](#).

A list of all parts in the ISO 6626 series can be found on the ISO website.

Any feedback or questions on this document should be directed to the user's national standards body. A complete listing of these bodies can be found at www.iso.org/members.html.

Introduction

The ISO 6626 series is one of a series of International Standards dealing with piston rings for reciprocating internal combustion engines. Others are the ISO 6621 series, ISO 6622, ISO 6623, ISO 6624, ISO 6625, the ISO 6626 series and ISO 6627.

The common features and dimensional tables presented in this document constitute a broad range of variables and, in selecting a particular ring type, the designer should be aware of the conditions under which it will be required to operate.

iTeh Standards
(<https://standards.iteh.ai>)
Document Preview

[ISO/FDIS 6626-2](https://standards.iteh.ai/catalog/standards/iso/b630565a-351f-4eb6-8a52-f77a74e4db79/iso-fdis-6626-2)

<https://standards.iteh.ai/catalog/standards/iso/b630565a-351f-4eb6-8a52-f77a74e4db79/iso-fdis-6626-2>

Internal combustion engines — Piston rings —

Part 2:

Coil-spring-loaded oil control rings of narrow width made of cast iron

1 Scope

This document specifies the essential dimensional features of coil-spring loaded oil control rings made of cast iron, types DSF-C, SSF, GSF, DSF, SSF-L, DSF-NG and DSF-CNP. It is applicable to those piston rings in sizes 60 mm up to 160 mm, inclusive for reciprocating internal combustion engines for road vehicles and other applications.

2 Normative references

The following documents are referred to in the text in such a way that some or all of their content constitutes requirements of this document. For dated references, only the edition cited applies. For undated references, the latest edition of the referenced document (including any amendments) applies.

ISO 6621-3, *Internal combustion engines — Piston rings — Part 3: Material specifications*

ISO 6621-4, *Internal combustion engines — Piston rings — Part 4: General specifications*

ISO 6621-5, *Internal combustion engines — Piston rings — Part 5: Quality requirements*

3 Terms and definitions

No terms and definitions are listed in this document.

ISO and IEC maintain terminology databases for use in standardization at the following addresses:

- ISO Online browsing platform: available at <https://www.iso.org/obp>
- IEC Electropedia: available at <https://www.electropedia.org/>

4 Overview

The coil-spring loaded oil control ring types are specified in [Figures 1](#) to [8](#). Their common features and the features' dimensions are specified in [Tables 1](#) to [5](#) and shown in [Figures 9](#) to [11](#). Essential features of coil springs are shown in [Figures 12](#) to [16](#). [Tables 8](#) to [16](#) give the dimensions of coil-spring loaded oil control rings.

The common features and dimensional tables presented in this document constitute a broad range of variables and, in selecting a particular ring type, the designer shall bear in mind the conditions under which it will be required to operate.

The designer shall refer to the specifications and requirements of ISO 6621-3 and ISO 6621-4 before completing a selection.

For the cast iron part, the recommended material is class 10 and shall be in accordance with ISO 6621-3. For special applications, material classes 20 to 50 may be used.

Variation from these in face design and spring groove may be used, as recommended by individual manufacturers, in plain or chromed versions.

5 Piston ring types and designation

5.1 Types DFS-C, DFS-CNP, SSF, GSF, DSF, DSF-NG, and SSF-L — General features and dimensions

See [Figure 1](#) and [Tables 8](#) to [16](#). [Figure 1](#) is applicable to [Figures 2](#) to [8](#). [Figures 2](#) to [8](#) show detailed cross sections corresponding to [Figure 1](#).

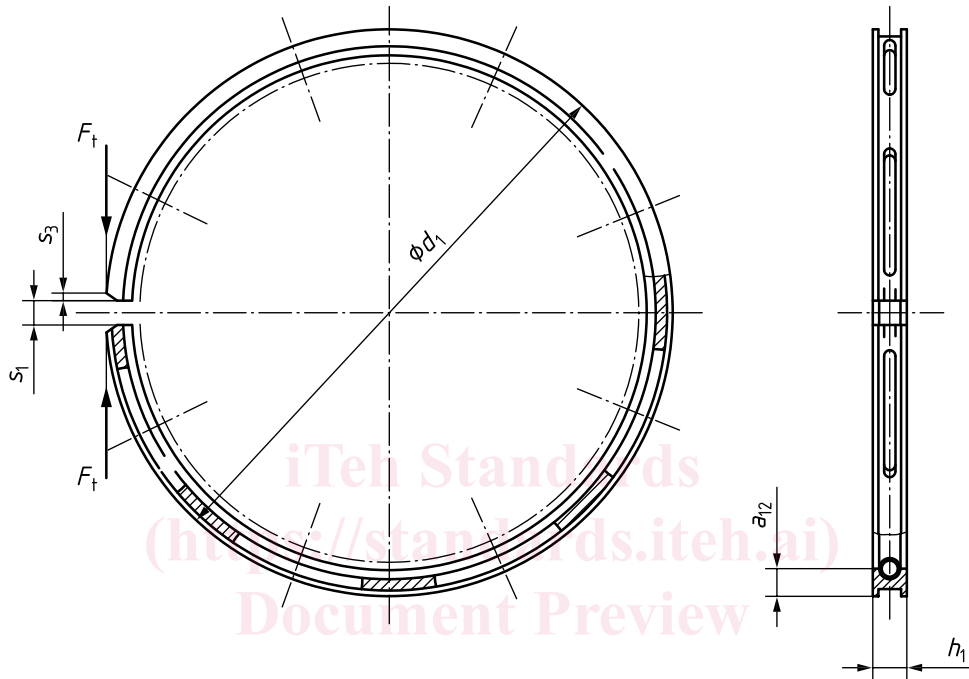
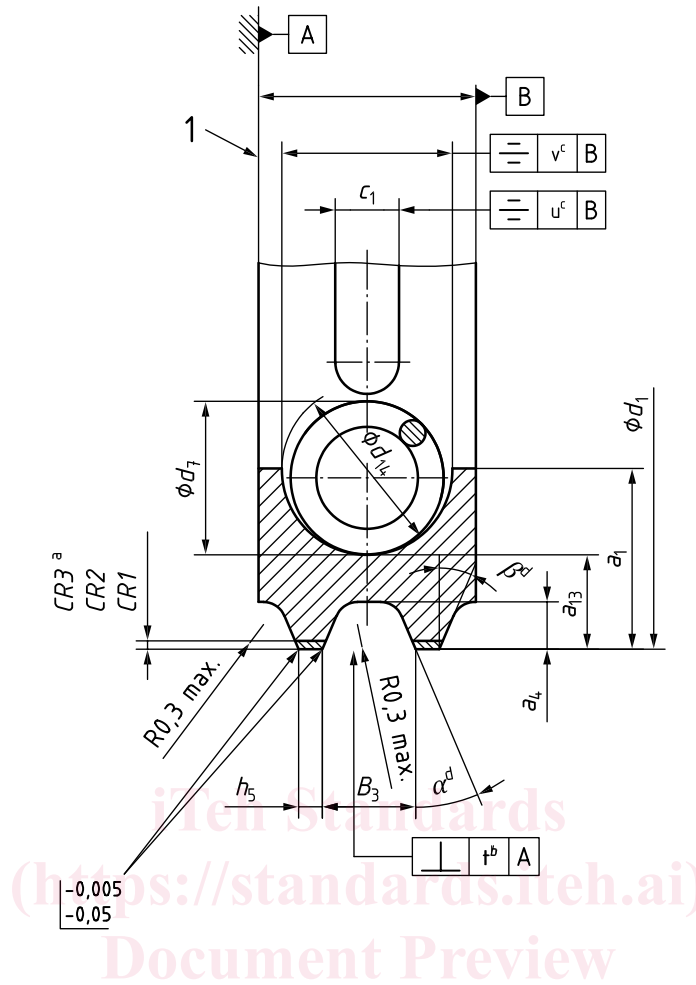

Figure 1 — Types DSF-C, SSF, GSF, DSF, SSF-L, DSF-NG and DSF-CNP

5.2 Type DSF-C — Coil-spring loaded bevelled edge oil control ring, chromium plated and profile ground

5.2.1 General features and dimensions

See [Figure 2](#) and [Tables 6](#) and [7](#).



Key

- 1 reference plane
- a See [Table 3](#).
- b See [Table 4](#).
- c See [Table 5](#).
- d Angle α and β to be agreed between manufacturer and customer, angles can be different (historical value is 35°).

Figure 2 — Type DSF-C

5.2.2 Designation of a Type DSF-C piston ring in accordance with ISO 6626-2

EXAMPLE Coil-spring loaded bevelled edge oil control ring, chromium plated and profile ground (DSF-C), of nominal diameter $d_1 = 80$ mm (80), nominal ring width $h_1 = 2,5$ mm (2,5), land width $h_5 = 0,25$ mm (0,25), made of grey cast iron, non-heat treated, material subclass 11 (MC11), having a selected closed gap of 0,20 mm min. (S020), a chromium layer thickness on the lands of 0,10 mm (CR2), reduced slot length (WK), a coil spring with reduced heat set (WF), and a variable pitch with coil diameter d_7 ground (CSE), with tangential force F_t in accordance with the nominal contact pressure $p_0 = 1,0$ N/mm² (PN1,0) and the ring marked with the manufacturer's mark (MM). Parameters in parenthesis are used in the ISO ring designation:

Piston ring ISO 6626-2 DSF-C - 80 × 2,5 × 0,25 - MC11 / S020 CR2 WK WF CSE PN1,0 MM

5.3 Type DSF-CNP – Coil-spring loaded bevelled edge oil control ring, chromium plated not profile ground

5.3.1 General features and dimensions

See Figure 3 and Tables 8 and 9.

Dimensions in millimetres

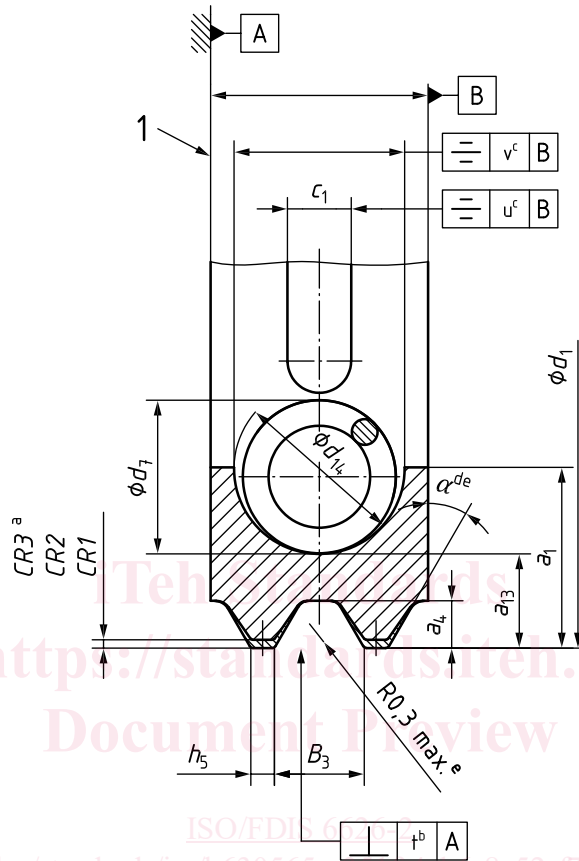

Key

- 1 reference plane
- a See Table 3.
- b See Table 4.
- c See Table 5.
- d Angle α and β to be agreed between manufacturer and customer, angles can be different (historical value is 35°).
- e Before plating.

Figure 3 — Type DSF-CNP

5.3.2 Designation of a Type DSF-CNP piston ring in accordance with ISO 6626-2

EXAMPLE Coil-spring loaded bevelled edge oil control ring, chromium plated not profile ground (DSF-CNP) of nominal diameter $d_1 = 100$ mm (100), nominal ring width $h_1 = 2,0$ mm (2,0), land width $h_5 = 0,25$ mm (0,25), made of grey cast iron, non-heat treated, material subclass 12 (MC12), constant spring pitch (CSN) and tangential force F_t in accordance with the nominal contact pressure $p_0 = 1,0$ N/mm² (PN1,0). Parameters in parenthesis are used in the ISO ring designation:

Piston ring ISO 6626-2 DSF-CNP- 100 × 2 × 0,25 - MC12 / CSN PN1,0

5.4 Type SSF – Coil-spring loaded slotted oil control ring

5.4.1 General features and dimensions

See [Figure 4](#) and [Table 10](#).

Dimensions in millimetres

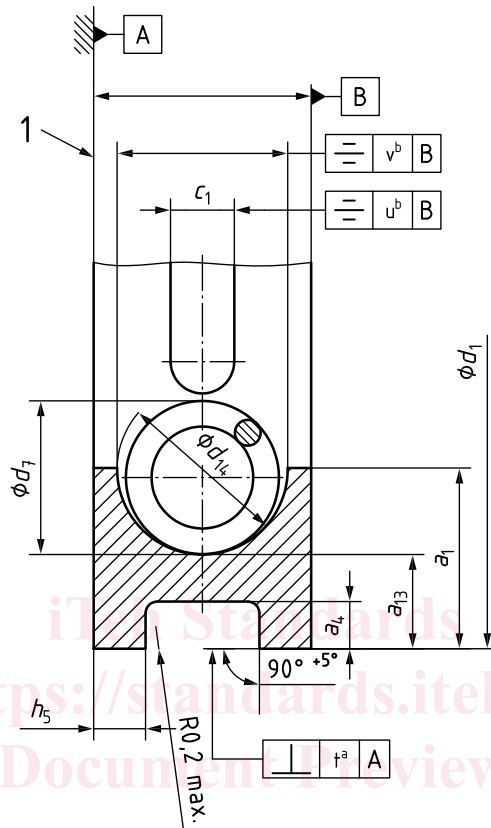

Key

- 1 reference plane
- a See [Table 4](#).
- b See [Table 5](#).

Figure 4 — Type SSF

5.4.2 Designation of a Type SSF piston ring in accordance with ISO 6626-2

EXAMPLE Coil-spring loaded slotted oil control ring with rectangular groove (SSF) of nominal diameter $d_1 = 80$ mm (80), nominal ring width $h_1 = 2,5$ mm (2,5), land width $h_5 = 0,50$ mm (0,50), made of grey cast iron, non-heat treated, material subclass 12 (MC12), constant spring pitch (CSN) and tangential force F_t in accordance with the nominal contact pressure $p_0 = 1,0$ N/mm² (PN1,0). Parameters in parenthesis are used in the ISO ring designation:

Piston ring ISO 6626-2 SSF- 80 × 2,5 × 0,50 - MC12 / CSN PN1,0

5.5 Type GSF – Coil-spring loaded double bevelled oil control ring

5.5.1 General features and dimensions

See [Figure 5](#) and [Table 11](#). Top side marking is mandatory in accordance with ISO 6621-4.