



Designation: ~~C779/C779M—05 (Reapproved 2010)~~ C779/C779M – 12

Standard Test Method for Abrasion Resistance of Horizontal Concrete Surfaces¹

This standard is issued under the fixed designation C779/C779M; the number immediately following the designation indicates the year of original adoption or, in the case of revision, the year of last revision. A number in parentheses indicates the year of last reapproval. A superscript epsilon (ϵ) indicates an editorial change since the last revision or reapproval.

1. Scope—Scope*

1.1 This test method covers three procedures for determining the relative abrasion resistance of horizontal concrete surfaces. The procedures differ in the type and degree of abrasive force they impart, and are intended for use in determining variations in surface properties of concrete affected by mixture proportions, finishing, and surface treatment. They are not intended to provide a quantitative measurement of the length of service that may be expected from a specific surface.

1.2 The values stated in either SI units or inch-pound units are to be regarded separately as standard. Within the text, the inch-pound units are shown in brackets. The values stated in each system may not be exact equivalents; therefore, each system shall be used independently of each other.

1.3 *This standard does not purport to address all of the safety concerns, if any, associated with its use. It is the responsibility of the user of this standard to establish appropriate safety and health practices and determine the applicability of regulatory limitations prior to use. (Warning—Fresh hydraulic cementitious mixtures are caustic and may cause chemical burns to skin and tissue upon prolonged exposure.)*²

NOTE 1—Other procedures are available for measuring the abrasion resistance of concrete surfaces in addition to the three procedures contained in this test method. Consideration should be given to Test Methods C944 and C418. The test method most closely representing service conditions should be used.

2. Referenced Documents

2.1 *ASTM Standards:*³

[C125 Terminology Relating to Concrete and Concrete Aggregates](#)

[C418 Test Method for Abrasion Resistance of Concrete by Sandblasting](#)

[C670 Practice for Preparing Precision and Bias Statements for Test Methods for Construction Materials](#)

[C944 Test Method for Abrasion Resistance of Concrete or Mortar Surfaces by the Rotating-Cutter Method](#)

3. Terminology

3.1 For definitions of terms used in this standard, refer to Terminology [C125](#).

4. Significance and Use

4.1 The three test methods provide simulated abrasion conditions, which can be used to evaluate the effects on abrasion resistance of concrete, concrete materials, and curing or finishing procedures. They may also be used for quality acceptance of products and surface exposed to wear. They are not intended to provide a quantitative measurement of length of service.

4.2 The equipment used by each of these procedures is portable and thus suitable for either laboratory or field testing. The three procedures determine the relative wear of concrete surfaces as follows:

4.2.1 *Procedure A*—The revolving-disk machine operates by sliding and scuffing of steel disks in conjunction with abrasive grit.

4.2.2 *Procedure B*—The dressing-wheel machine operates by impact and sliding friction of steel dressing wheels.

4.2.3 *Procedure C*—The ball-bearing machine operates by high-contact stresses, impact, and sliding friction from steel balls.

¹ This test method is under the jurisdiction of ASTM Committee C09 on Concrete and Concrete Aggregates and is the direct responsibility of Subcommittee C09.62 on Abrasion Testing.

Current edition approved Oct. 1, 2010/Dec. 1, 2012. Published December 2010/December 2012. Originally approved in 1974. Last previous edition approved in 2005/2010 as ~~C779—05-C779—05(2010)~~. DOI: ~~10.1520/C0779_C0779M-05(2010)~~; 10.1520/C0779_C0779M-12.

² Section on Safety Precautions, *Manual of Aggregate and Concrete Testing, Annual Book of ASTM Standards*, Vol. 04.02.

³ For referenced ASTM standards, visit the ASTM website, www.astm.org, or contact ASTM Customer Service at service@astm.org. For *Annual Book of ASTM Standards* volume information, refer to the standard's Document Summary page on the ASTM website.

*A Summary of Changes section appears at the end of this standard

NOTE 2—Diagrams of three machines meeting these specifications are shown in Fig. 1, Fig. 2, and Fig. 3.⁴

PROCEDURE A—REVOLVING DISKS

5. Apparatus

5.1 The function of the apparatus is dependent upon the abrasive action of the flat faces of three 60-mm (2³/₈-in.) diameter, cold-rolled steel revolving disks, each attached to motor-driven vertical shafts which also revolve about a vertical axis. The inside diameter of the resulting circular and abraded track shall be approximately 150 mm (6 in.) and the outside diameter 275 mm (11 in.). Crossed slots 90° to each other and cut 5 mm (3/16 in.) deep and 6 mm (1/4 in.) wide are located symmetrically in the abrasive flat faces.

5.2 The disks are free floating inasmuch as they are self-supporting and are driven transversely along a circular path at 12 rev/min (12 rpm) while being individually turned on their own axis at 280 rev/min (280 rpm). Cups attached at the top of the shaft of each disk shall be loaded with lead shot to produce a uniform total load of 22 N (5 lbf) on each abrading disk face.

5.3 The abrasive grit shall consist of 250 μ [No. 60] silicon carbide. This is fed from a storage cup mounted on the revolving circular plate through a 3-mm (1/8-in.) orifice passing through the plate. The flow of abrasive shall be controlled to a rate of 4 to 6 g/min by an adjusting needle located in the orifice. The abrasive falls at the midwidth of the circular abraded track, and midway between two of the disks.

5.4 The micrometer bridge consists of a machine-finished 25-mm (1-in.) rectangular steel bar of at least 300-mm (12-in.), clear span supported by a tripod and drilled along its centerline with ten 3-mm (1/8-in.) diameter holes spaced 6-mm (1/4 in.) on center. The measuring instrument is a depth micrometre with a needle having an effective depth range of 25 to 50 mm (1 to 2 in.) and graduated to an accuracy of at least 0.025 mm (0.001 in.).

iTeh Standards

⁴ The sole source of supply of these machines known to the committee at this time is White Machine Co., 9591 York Alpha Dr., North Royalton, OH 44133; Spirit Fabricating, Ltd., 9260 Valley View Rd., Macedonia, OH 44056. If you are aware of alternative suppliers, please provide this information to ASTM International Headquarters. Your comments will receive careful consideration at a meeting of the responsible technical committee,¹ which you may attend.

Document Preview

ASTM C779/C779M-12

<https://standards.iteh.ai/catalog/standards/sist/63088888-8-bb17-4-9971-badd882811fa/astm-c779-c779m-12>

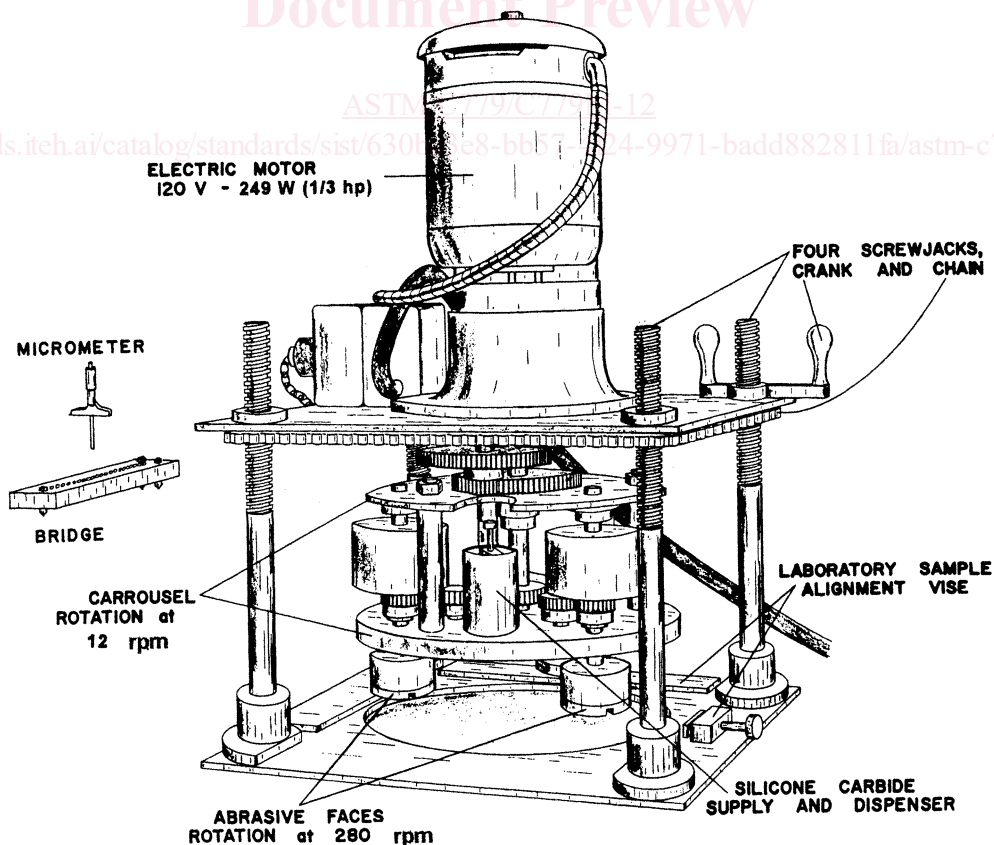

FIG. 1 Revolving Disks Abrasion Test Machine

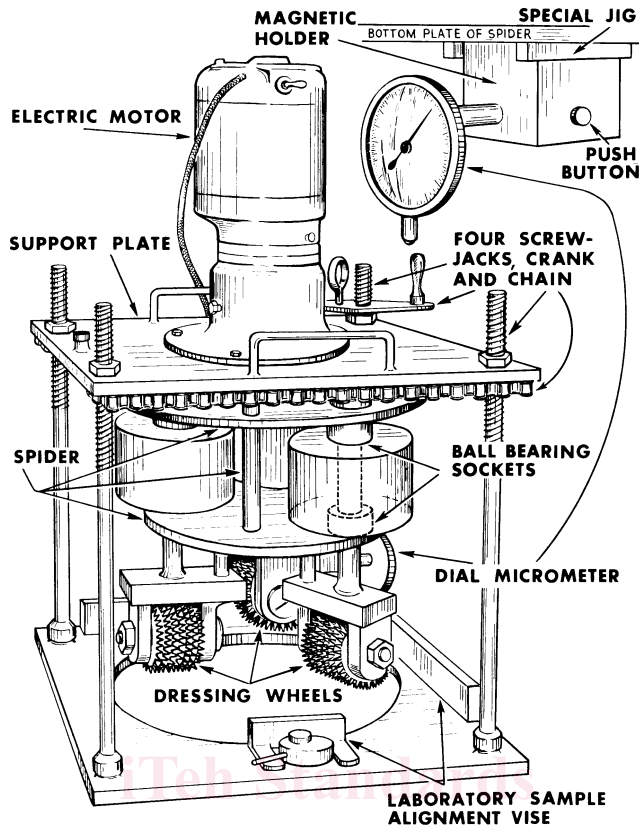

FIG. 2 Dressing Wheel Abrasion Test Machine

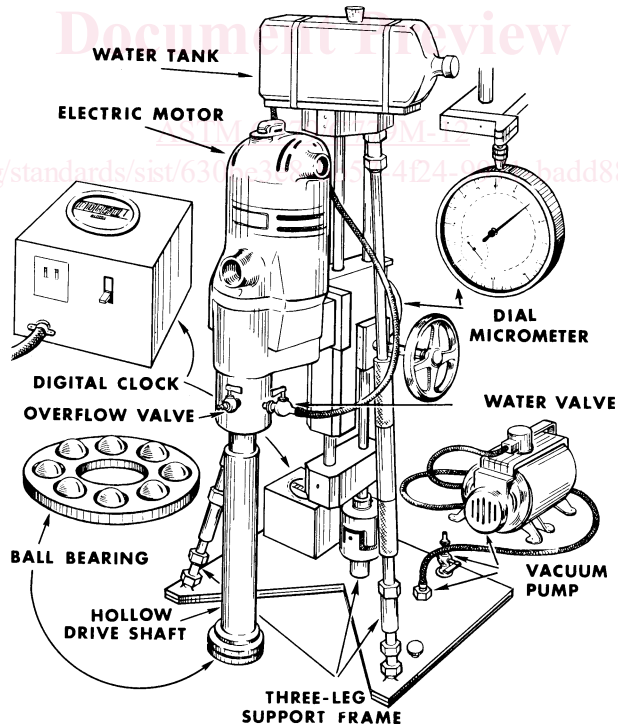

FIG. 3 Ball Bearing Abrasion Test Machine

6. Test Specimen

6.1 For laboratory test purposes, the machine is designed to accommodate approximately 300 by 300-mm (12 by 12-in.) test specimens. The apparatus is equipped with an adjusting handle linked by a sprocket and chain-drive assembly to the four 25-mm