



# Standard Test Method for Contamination Outgassing Characteristics of Spacecraft Materials<sup>1</sup>

This standard is issued under the fixed designation E 1559; the number immediately following the designation indicates the year of original adoption or, in the case of revision, the year of last revision. A number in parentheses indicates the year of last reapproval. A superscript epsilon ( $\epsilon$ ) indicates an editorial change since the last revision or reapproval.

## 1. Scope

1.1 This test method covers a technique for generating data to characterize the kinetics of the release of outgassing products from materials. This technique will determine both the total mass flux evolved by a material when exposed to a vacuum environment and the deposition of this flux on surfaces held at various specified temperatures.

1.2 This test method describes the test apparatus and related operating procedures for evaluating the total mass flux that is evolved from a material being subjected to temperatures that are between 298 and 398K. Pressures external to the sample effusion cell are less than  $7 \times 10^{-3}$  Pa ( $5 \times 10^{-5}$  torr). Deposition rates are measured during material outgassing tests. A test procedure for collecting data and a test method for processing and presenting the collected data are included.

1.3 This test method can be used to produce the data necessary to support mathematical models used for the prediction of molecular contaminant generation, migration, and deposition.

1.4 All types of organic, polymeric, and inorganic materials can be tested. These include polymer potting compounds, foams, elastomers, films, tapes, insulations, shrink tubing, adhesives, coatings, fabrics, tie cords, and lubricants.

1.5 There are two test methods in this standard. Test Method A uses standardized specimen and collector temperatures. Test Method B allows the flexibility of user-specified specimen and collector temperatures, material and test geometry, and user-specified QCMs.

1.6 The values stated in SI units are to be regarded as the standard.

1.7 *This standard does not purport to address all of the safety concerns, if any, associated with its use. It is the responsibility of the user of this standard to establish appropriate safety and health practices and determine the applicability of regulatory limitations prior to use.*

## 2. Referenced Documents

### 2.1 ASTM Standards:

E 177 Practice for Use of the Terms Precision and Bias in

<sup>1</sup> This test method is under the jurisdiction of ASTM Committee E-21 on Space Simulation and Applications of Space Technology and is the direct responsibility of Subcommittee E21.05 on Contamination.

Current edition approved Oct. 10, 2000. Published January 2001. Originally published as E 1559 – 93. Last previous edition E 1559 – 93.

### ASTM Test Methods<sup>2</sup>

E 595 Test Method for Total Mass Loss and Collected Volatile Condensable Materials from Outgassing in a Vacuum Environment<sup>3</sup>

IEEE/ASTM SI 10-1997 Standard for Use of the International System of Units (SI): The Modern Metric System<sup>2</sup>

### 2.2 Military Standard:

MIL-P-27401C Propellant Pressurizing Agent, Nitrogen<sup>4</sup>

## 3. Terminology

### 3.1 Definitions:

3.1.1 *AT cut crystal, n*—a quartz crystal orientation that minimizes the temperature coefficient (frequency change versus temperature) over a wide range of temperature.

3.1.2 *collected volatile condensable material, CVCM, n*—(from Test Method E 595). The quantity of outgassed matter from a test specimen that condenses on a collector maintained at a specific constant temperature for a specified time and measured before and after the test outside the chamber.

3.1.2.1 *Discussion*—CVCM is specific to Test Method E 595 and is calculated from the condensate mass determined from the difference in mass of the collector plate before and after the test in a controlled laboratory environment. CVCM is expressed as a percentage of the initial specimen mass. The view factor is not considered; so all the VCM outgassing from the sample may not be collected. Care should be used in comparing the CVCM from Test Method E 595 with VCM from this test method.

3.1.3 *differential scanning calorimetry, DSC, n*—a technique in which the difference in energy inputs into a substance and a reference material is measured as a function of temperature while the substance and reference material are subjected to a controlled-temperature program.

3.1.4 *effusion cell, n*—a container, placed in a vacuum, in which a sample of material can be placed and heated to some specified temperature.

3.1.4.1 *Discussion*—The container has a cylindrical orifice at one end so that evolving gases exit the cell in a controlled manner. The effusion cell dimensions and orifice size are

<sup>2</sup> *Annual Book of ASTM Standards*, Vol 14.02.

<sup>3</sup> *Annual Book of ASTM Standards*, Vol 15.03.

<sup>4</sup> Available from Standardization Documents Order Desk, Bldg. 4 Section D, 700 Robbins Ave., Philadelphia, PA 19111-5094, Attn: NPODS.

specified such that there is free molecular flow of the evolving gasses and a predictable molecular flux from the orifice.

3.1.5 *mass flux, n*—the mass of molecular flux.

3.1.6 *molecular flux (molecules·cm<sup>-2</sup>·s<sup>-1</sup>), n*—the number of gas molecules crossing a specified plane in unit time per unit area.

3.1.7 *nonvolatile residue, NVR, n*—the quantity of residual molecular and particulate matter remaining following the filtration of a solvent containing contaminants and evaporation of the solvent at a specified temperature.

3.1.8 *outgassing, n*—the evolution of gas from a material, usually in a vacuum. Outgassing also occurs in a higher pressure environment.

3.1.9 *quartz crystal microbalance, QCM, n*—a device for measuring small quantities of mass using the properties of a quartz crystal oscillator.

3.1.9.1 *Discussion*—The resonant frequency of a quartz crystal oscillator is inversely proportional to the thickness of the crystal. When the mass of a uniform deposit is small relative to the mass of the crystal, the change in frequency is proportional to the mass of the deposit.

3.1.10 *QCM thermogravimetric analysis, QTGA, n*—a technique in which a QCM is heated at a constant rate to remove a collected deposit.

3.1.10.1 *Discussion*—This is performed to determine the evaporation characteristics of the species in the deposit. The mass of the deposit on the QCM is recorded as a function of time or temperature.

3.1.11 *residual gas analyzer, RGA, n*—a mass spectrometer mounted inside or attached to a vacuum chamber.

3.1.11.1 *Discussion*—RGA can be used for identifying gases in the vacuum chamber.

3.1.12 *total mass flux (g·cm<sup>-2</sup>·s<sup>-1</sup>), n*—the summation of the mass from all molecular species crossing a specified plane in unit time per unit area.

3.1.13 *total mass loss, TML, n*—total mass of material outgassed from a test specimen that is maintained at a specified constant temperature and operating pressure for a specified time and measured within the test chamber. TML is expressed as a percentage of the initial specimen mass. In addition, TML can be normalized with respect to the sample surface area and be expressed as  $\mu\text{g}/\text{cm}^2$ .

3.1.13.1 *in-situ TML, n*—calculated from the mass deposited on a cryogenically cooled QCM and the view factor from the effusion cell orifice to the QCM.

3.1.13.2 *Discussion*—In-situ TML is a function of the outgassing test time and is expressed as a percentage of the initial specimen mass. This is not necessarily the same as the TML determined by Test Method E 595.

3.1.13.3 *ex-situ TML, n*—total mass of material outgassed from a test specimen that is maintained at a specified constant temperature and operating pressure for a specified time and measured outside the test chamber.

3.1.13.4 *Discussion*—Ex-situ TML is calculated from the mass of the specimen as measured before and after the test in a controlled laboratory environment and is expressed as a percentage of the initial specimen mass. (From Test Method E 595.)

3.1.14 *total outgassing rate, n*—the net rate of mass loss from a material sample as a result of outgassing. Total outgassing rate can be normalized per unit sample surface area and expressed as  $\text{g}\cdot\text{cm}^{-2}\cdot\text{s}^{-1}$  or it can be normalized per unit initial sample mass and expressed as  $\text{g}\cdot\text{g}^{-1}\cdot\text{s}^{-1}$ .

3.1.15 *volatile condensable material, VCM, n*—the matter that outgasses from a material and condenses on a collector surface that is at a specified temperature.

3.1.15.1 *Discussion*—For this test method, this is the quantity of outgassed matter from a test specimen that condenses on surfaces maintained at QT2 or QT3. The VCM is calculated from the mass deposited on QCM2 or QCM3 and the view factor from the effusion cell orifice to the QCMs. VCM is a function of the outgassing test time and is expressed as a percentage of the initial specimen mass. In addition, VCM can be normalized with respect to the sample surface area and be expressed as  $\mu\text{g}/\text{cm}^2$ . This is not the same as CVCM as determined by Test Method E 595 (see 3.1.2).

3.2 *Acronyms:*

3.2.1 *GN<sub>2</sub>, n*—gaseous nitrogen.

3.2.2 *LN<sub>2</sub>, n*—liquid nitrogen.

3.2.3 *MAPTIS, n*—Materials and Process Technical Information Service.

3.3 *Definitions of Terms Specific to This Standard:*

3.3.1 *QCM1*—the QCM that is operating at the temperature TQ1 (cryogenic) for measuring the total outgassing rate.

3.3.2 *QCM2 and QCM3*—the QCMs that are operating at temperatures TQ2 and TQ3 for the measurement of the deposition of outgassing matter.

## 4. Summary of Test Method

4.1 The test apparatus described in this test method is designed to measure outgassing rate data that can be used to develop kinetic expressions for use in models that predict the evolution of molecular contaminants and the migration and deposition of these contaminants on spacecraft surfaces. Materials that contain volatile species that will be outgassed under the temperature and vacuum conditions of this test method can be characterized. The quartz crystal microbalances used in this test method provide a sensitive technique for measuring very small quantities of deposited mass. In addition to providing data for kinetic expressions, the reduced data can be used to compare the outgassing behavior of different materials for material selection purposes.

4.2 There are two test methods in this standard. Test Method A is the standard procedure using prescribed configurations and temperatures. Test Method B allows for the use of spacecraft system specific temperatures, configurations, and QCM collector surface finishes.

4.3 The measurements are made by placing the material sample in an effusion cell so that the outgassing flux leaving the cell orifice will impinge on three QCMs which are arranged to view the orifice. A fourth QCM is optional. The effusion cell is held at a constant temperature in the high vacuum chamber and has a small orifice directed at the QCMs. The QCMs are controlled to selected temperatures. The total outgassing rate is determined from the collection rate on a cryocooled QCM. At the end of the isothermal test, the QCMs are heated in a

controlled manner to determine the evaporation characteristics of the deposits.

4.4 The effusion cell is loaded from the vacuum interlock chamber to the main test chamber and is positioned at a fixed distance and angle with respect to the QCM surfaces. The effusion cell is temperature controlled to provide constant and uniform heating of the sample. The vacuum interlock chamber is a device that enables the expedient introduction of the test sample into the high vacuum of the main test chamber. Use of the interlock chamber to load and unload samples prevents loss of vacuum in the main chamber and diminishes the need to pump it down before each test.

4.5 The QCM collection method for measuring the total outgassing rate from a sample is an indirect technique. Rather than directly measuring sample mass loss, the basic measurement is the fraction of the flux that condenses on the cryogenically cooled QCM collector at a point in the outgassing flow field. That point in the flow field is defined as the geometric location of the QCM relative to the effusion cell orifice, which is at a fixed location. To determine the rate of sample mass loss from the rate of QCM collection, the view factor from the QCM to the effusion cell orifice and the angular distribution of flux leaving the orifice must be determined. This relationship can be calculated from the apparatus geometry and the effusion cell orifice dimensions.

4.6 A QCM thermogravimetric analysis (QTGA) test is also included in the procedure. This technique heats the QCMs at a constant rate to measure evaporation characteristics of the deposits collected on the QCMs. The QTGA also provides an effective means to clean the QCM surfaces before subsequent tests.

4.7 It is critical to the posttest analysis that the material sample be completely described and specified, so that the outgassing characteristics can be applied to the material when used on a spacecraft. It is also necessary so that any material sample can be properly compared with that of other samples. The outgassing rate of the material will, in general, be determined by its composition, processing history, and environmental conditioning before the test. All test sample processing should be representative of normal material processing and usage. All materials are environmentally conditioned to specified conditions. However, samples may be subjected to environmental conditions that are expected during actual use. Test sample processing and conditioning history shall be included in the test report.

4.8 Because outgassing of all materials is, to some extent, diffusion rate controlled, the outgassing rate of a test sample depends on the distance from the sample interior to a free surface. Hence, the geometry of a test sample must be controlled in a specified manner to permit meaningful interpretation of the data. When possible, the sample geometry should be in the specified configuration to simplify modeling. However, the material sample can be made with the same geometry as it would have in an actual application.

## 5. Test Apparatus

5.1 *Description*—The test apparatus consists of four main subsystems: a vacuum chamber, a temperature control system, internal configuration, and a data acquisition system. Fig. 1 is

a schematic of the systems, and Fig. 2 shows the vacuum chamber and internal configuration.

5.2 *Vacuum Chamber*—The principal components of the vacuum chamber are the main test chamber, the vacuum interlock chamber, and cryogenic shrouds (for example,  $LN_2$ ). A high-vacuum gate valve is used to isolate the main test chamber from the interlock chamber. This allows the effusion cell to be withdrawn or inserted into the main chamber without the loss of high vacuum in the main chamber. High-vacuum electrical and mechanical feedthroughs are used to access the interior of the chamber.

5.3 *Internal Configuration*—Three quartz crystal microbalances (QCMs) (a fourth QCM is optional), an effusion cell, and cryogenic heat sinks in the chamber are the principal components. The cryogenic heat sinks are used to ground the QCMs thermally and to cool shrouds which surround the effusion cell and QCMs. The cold shrouds limit molecular contaminant fluxes to the line-of-sight outgassing flux from the effusion cell orifice to the collector QCMs. The cryogenic heat sink system ( $LN_2$  reservoirs) and shrouds, effusion cell, and QCMs are shown in Fig. 2.

5.3.1 The QCMs are thermally shielded from each other so that the temperatures of each can be controlled independently. Each QCM has its own temperature sensing and control system.

5.3.2 Each QCM contains two crystals (one for mass collection and one for reference), the oscillator electronics, and a temperature sensor. The QCM crystals shall have optically polished surfaces (60/40 cerium polish). Uncoated, aluminum electrodes shall be used for the sensing and reference crystals.

NOTE 1—The quantitative effect of the surface finish on the deposition rates is not known at this time. A diffuse surface has more surface area than a polished surface resulting in more conservative (higher) values of contaminant accumulation, especially with monolayer thicknesses. However, diffuse surfaces are difficult to reproduce and clean uniformly, resulting in unwanted test variability. Future round-robin tests will be used to evaluate the effects of surface finish on the results.

NOTE 2—Aluminum electrodes are easy to apply and to clean. If it is desirable to measure deposition on a simulated optical surface, a QCM that simulates the surface roughness and composition of the optical surfaces may be used in Test Method B. Future round-robin tests will be used to evaluate the effects of surface composition on the results.

5.3.3 The QCMs are thermally connected to a cryogenic heat sink (that is,  $LN_2$ ), and heaters provide the temperature control above the base temperature ( $\leq 90K$ ). The QCMs shall be controllable from the set points specified in 9.3 or 9.4 to 398K and maintained to within  $\pm 0.5K$  of the desired temperature.

5.3.4 The required sensitivity of the QCM to mass deposits depends upon the required precision of the mass measurements. Sensitivity is a function of the crystal cut, temperature, and natural frequency of the quartz crystals. QCMs used for this test method shall have a sensitivity of at least  $1 \times 10^{-8}$  g·cm<sup>-2</sup>·Hz<sup>-1</sup> at 298K. Table 1 shows the theoretical sensitivities of quartz crystals.<sup>5</sup> The sensitivity of the QCMs shall be sufficient to measure the incident mass fluxes required to perform the test.

<sup>5</sup> Wrought aluminum alloys such as the 2000 and 6000 series can be used.

ASTM E 1559

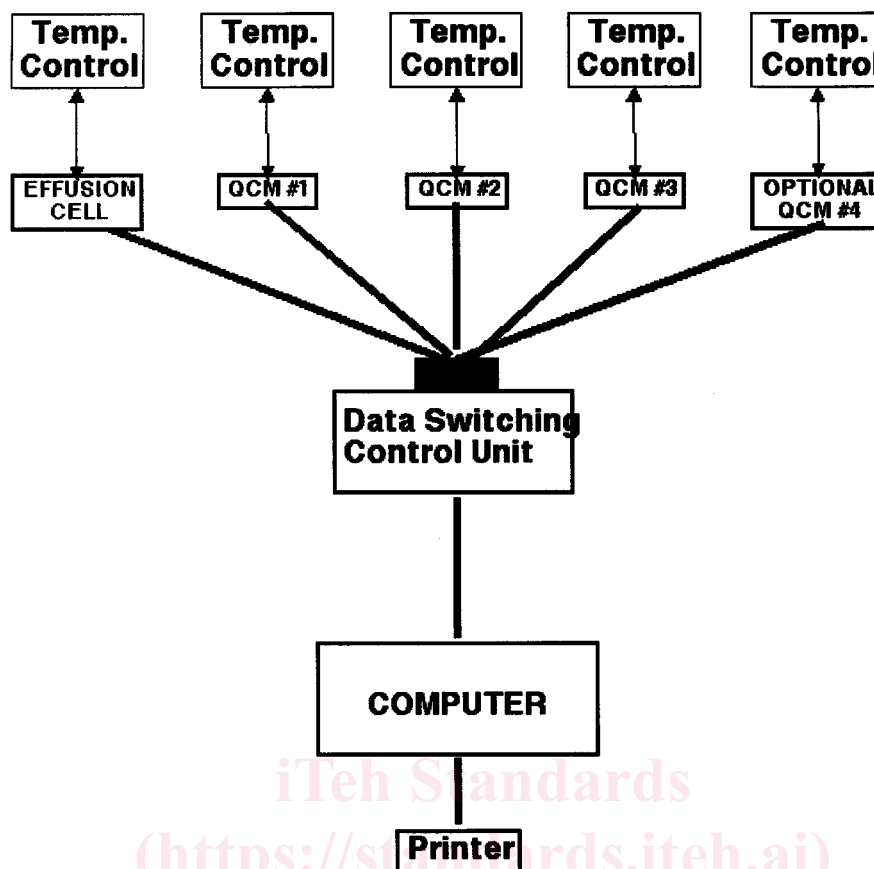

FIG. 1 Data System and Control Schematic

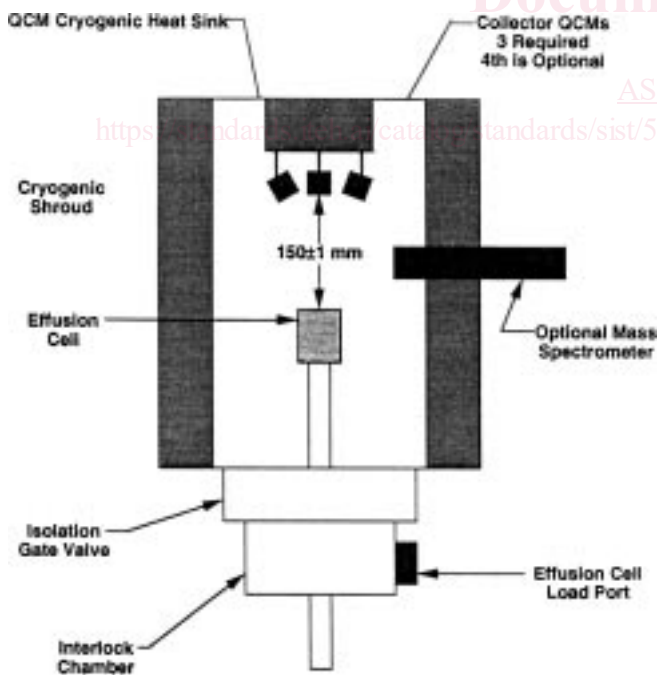

FIG. 2 Test Chamber

NOTE 3—QCMs with 10- or 15-MHz crystals are typically used. The sensitivities in Table 1 assume that the areas of the electrodes on both sides of a crystal are the same.

5.3.5 The QCMs are arranged symmetrically so that each QCM has the same view factor to the effusion cell orifice. The

TABLE 1 AT or Rotated Cut Crystal with Identical Electrode Areas on Each Side of the Crystal

Natural Frequency ( $f$ ), MHz	Sensitivity at 298K ( $K_s$ ), $\text{g}\cdot\text{cm}^{-2}\cdot\text{Hz}^{-1}$
10	$4.42 \times 10^{-9}$
15	$1.96 \times 10^{-9}$
20	$1.10 \times 10^{-9}$

QCMs are angled  $10 \pm 0.5^\circ$  off the normal to the plane of the effusion cell orifice so that the axes of the QCMs intersect at a common point that coincides with the location of the effusion cell orifice when the cell is placed in its standard position. The distance from the effusion cell orifice to each QCM collector surface is  $150 \pm 1$  mm.

NOTE 4—This QCM to collector surface geometry is mandated for Test Method A. See 9.1 for Test Method B, allowing nonstandard geometries and test conditions.

NOTE 5—The QCMs shall be placed so that the active surface of any QCM cannot “see” the active surface of any other QCM.

5.3.6 The effusion cell is cylindrical and the recommended dimensions are  $65 \pm 5$ -mm inside diameter by  $50 \pm 5$  mm in depth. Effusion cell dimensions shall accommodate the standard sample geometries described in Section 8. The flux distribution of the outgassing products leaving the effusion cell is controlled by the cylindrical orifice in the top of the effusion cell. The orifice size shall be  $3.0 \pm 0.1$ -mm diameter by  $3.0 \pm 0.1$ -mm long.



NOTE 6—This orifice size is mandated for conformance to this test method.

5.3.7 The cell shall be machined from aluminum<sup>5</sup> or copper<sup>6</sup> for high thermal conductivity. The cell shall have an integral heater and temperature sensor. The integral heater shall be capable of uniformly heating the effusion cell to 398K within 20 min after inserting the cell into the main vacuum chamber.

5.3.8 Effusion cell temperatures shall be controlled to within  $\pm 0.5\text{K}$ .

5.3.9 The positioning mechanism shall place the exit plane of the effusion cell orifice at a distance of  $150 \pm 1$  mm from the surface of the sensing crystal in each QCM.

5.3.10 A shroud, cooled with a cryogenic heat sink, shall surround the effusion cell to minimize the reflection of molecular flux from the chamber wall to the QCMs. A shutter may be used over the orifice to isolate the QCMs from the molecular flux.

5.4 *Temperature Control System*—All temperatures of the effusion cell and the QCMs are maintained by independently controlled heaters to a precision of  $\pm 0.5\text{K}$  or better. In addition to maintaining temperatures at selected specific values, the controller for the QCMs shall be capable of performing ramp functions, in which temperatures are increased at a constant rate of 1K per minute.

NOTE 7—Users should be aware that the QTGA heating rate can affect the test data. A heating rate of 1K per minute was selected for practicality. 1K per minute was found to provide good agreement with the predicted evaporation rates of water using vapor pressure data. Higher rates showed significant errors. This is covered in Footnote 7.<sup>7</sup> Lower rates have also shown differences but will result in long, impractical test times.

5.5 *Data Acquisition System*—Data acquisition, storage, and manipulation can be accomplished by any method that is capable of measuring the frequencies of the QCMs, the temperatures of the QCMs and the effusion cell, and the times of data collection at specified intervals. Experimental or processed data shall be stored for later retrieval for further analysis. An automated, computer operated data collection system is recommended.

## 6. Support Equipment/Materials

6.1 *Analytical Microbalance*, with a 30 g or greater tare, a readability of 10  $\mu\text{g}$  or better, and a precision of  $\pm 10 \mu\text{g}$  is required for recording mass changes of the samples.<sup>8</sup>

6.2 *Oil-Free Aluminum Foil*<sup>9</sup>, is recommended as a non-outgassing substrate.

6.3 *High Purity, Low NVR Solvents* are required for cleaning the effusion cell and other hardware before insertion into the vacuum chamber. Suitable reagent grade solvents include

<sup>5</sup> OFHC (oxygen free, high conductivity) copper has been found to be satisfactory.

<sup>7</sup> Glassford, A. P. M., Lockheed Palo Alto Research Laboratory, "Analysis of the Accuracy of a Commercial Quartz Crystal Microbalance," *Thermophysics of Spacecraft and Outer Planet Probes, AIAA Progress in Astronautics & Aeronautics*, Vol 56, A. M. Smith, Ed., 1977, pp. 175–196.

<sup>8</sup> Sartorius Model 2405 microbalance, Sartorius Model 2434 Semi-micro, or equivalent.

<sup>9</sup> Fed Spec Food Service Grade aluminum foil, oil free, Federal Stock No. 8135-00-724-0551 has been found to be satisfactory.

acetone, methanol, ethanol, 1,1,1 trichloroethane (methyl chloroform), and 75/25 % mixture of methyl chloroform and ethanol.

6.3.1 Low NVR hexane or toluene is required to clean QCM surfaces.

NOTE 8—Some QCMs may use materials on the electrodes that are not compatible with some solvents. Cleaning instructions from the QCM manufacturer should be followed.

6.3.2 Swabs shall be extracted to have a low NVR.<sup>10</sup>

6.3.3 Gloves shall be powder-free latex or polyethylene.<sup>11</sup>

6.4 An accurate micrometer is required to measure sample dimensions. Dimensions shall be determined to an accuracy of  $\pm 1$  % of the dimension.

## 7. Hardware Cleaning

NOTE 9—The following guidelines should be followed upon the removal of the QCMs.

### 7.1 Vacuum System:

7.1.1 Clean in accordance with good vacuum practices before assembly.

7.1.2 Metal components may be chemically cleaned using procedures appropriate to the material.

7.1.3 Some residual contamination may be removed using toluene, methyl ethyl ketone, or acetone. Perform a final rinse with a low NVR solvent (see 6.3).

NOTE 10—Cleaning with solvents may be hazardous. All procedures should be reviewed for conformance to local safety requirements.

NOTE 11—The background accumulation on the QCMs shall fall within the rates in 9.3.2. To meet these rates it may be necessary to bakeout the chamber in vacuum at temperatures up to 125°C. This should be performed without the QCMs or any other equipment installed that cannot tolerate the temperature.

### 7.2 QCMs:

7.2.1 Carefully rinse the QCM crystals with clean solvent as specified in 6.3.1 so as not to damage the electrode surfaces.

NOTE 12—Some electrodes are extremely delicate (such as gold), and care should be taken to prevent damage.

7.2.2 Extracted, seedless cotton balls or low NVR swabs<sup>12</sup> may be used to wipe the crystal surfaces gently to remove stubborn deposits.

NOTE 13—Soft electrode surfaces, such as gold, should be rinsed with the appropriate solvents and then cleaned using a vacuum bakeout. Mechanical cleaning, if required, must be done with great care.

7.2.3 If seedless cotton balls are used, they may be extracted using a low NVR solvent in an ultrasonic bath or by Soxhlet extraction. If an ultrasonic bath is used, at least two extraction cycles shall be used. Each cycle shall use clean solvent.

7.2.4 *QCM Sensor Housing*—Cleaning of the sensor housing shall follow good vacuum equipment practices and be compatible with the housing materials.

<sup>10</sup> Commercial swabs may be acceptable but should be tested before use for NVR and suitability for this application.

<sup>11</sup> Powder-free latex gloves are available commercially. Commercial gloves should be tested for suitability before use.

<sup>12</sup> Commercial swabs may be acceptable but should be tested before use for NVR and suitability for this application.

## 8. Test Specimen Specification

8.1 Outgassing kinetics depend upon the thickness of the material and the surface area exposed to vacuum. The geometry of a material test sample shall be representative of the application geometry for that material or selected such that the outgassing rates for other geometries can be inferred from the outgassing rate data measured for the test sample. The test sample geometry that satisfies this requirement depends on the physical processes involved in outgassing for the specific test material.

8.2 The dimensions of the sample and its holder or substrate, where applicable, shall be controlled, measured, and documented. Sample dimensions shall be measured to an accuracy of  $\pm 1\%$ . Sample surface area and volume are critical to data analysis. Fiber volume and inert filler composition shall be reported when applicable.

8.3 The sample mass can range from 0.5 to 10 g not including substrate. The specimen mass is determined by the quantity of outgassed deposits that can be measured accurately. This requirement is determined by apparatus measurement sensitivity limitations. The upper limit of specimen mass is determined by the saturation of the QCM when the mass of deposit becomes too large. With saturation, the circuit stops oscillating. In addition, when the deposit of the QCM is a liquid, the frequency change versus mass becomes nonlinear as the deposit becomes thicker.

8.4 The mass of the test sample and its holder or substrate, where applicable, shall be controlled, measured, and documented. Test sample mass shall be measured on a microbalance to an accuracy of  $\pm 10\ \mu\text{g}$ .

8.5 The identity and the procurement, acceptance, and application specifications of the material used for the test sample shall be documented. Identification markings shall not be applied to the sample. A separate ID tag that is removed during the test shall be used. The traceability of a particular material sample shall be achieved by specifying the supplier lot or batch number or both.

8.6 Unless special handling is specified, all samples shall be preconditioned before test by holding them at 296K (23°C) in a 50 % relative humidity environment for at least 24 h. This preconditioning procedure is the same as that specified in Test Method E 595.

8.7 It is suggested that materials such as laminates, adhesives, potting compounds, paints, and coatings that are typically “cured” in some fashion be screened for degree of cure before use in this test. The “degree of cure” for a sample can be performed in a differential scanning calorimetry (DSC) test apparatus that is commonly available in analytical chemistry labs. Materials that are not in a fully cured state can be expected to outgas more than one that is fully cured. Phase changes in these materials might occur during heating and could affect temperature measurements in the effusion cell.

NOTE 14—It is desirable for the specimen to be in good thermal contact with the effusion cell. However, this is affected by the shape and size of the specimen.

8.8 *Adhesives and Sealants*—Castable adhesives and sealants shall be cast and cured in a 10-mm-diameter by 25-mm-long tube. The tube shall be made of a nonoutgassing material.

Film, paste, filled, and supported adhesives shall be cured between two nonoutgassing plates, such as aluminum foil (see 6.2). Uniform edge thickness shall be maintained with dams, shim, or clamps which are removed for the test. The sample dimensions shall be 1 mm thick by 40 mm square. The exposed adhesive surface area shall be measured.

8.9 *Cable Insulation and Shrink Tubing*—Cable insulation and shrink tubing shall be tested in the as-supplied geometry.

8.10 *Conformal Coatings*—Conformal coatings shall be applied to a nonoutgassing substrate, such as aluminum foil (see 6.2). Cut the substrate into sections of small enough area to stack in the effusion cell. Do not pack tightly so that outgassing rates from the coating surfaces are constrained by venting geometry.

8.11 *Electrical Components*—Electrical components shall be tested in the as-supplied geometry.

8.12 *Electrical Shields*—Electrical shields shall be tested in the as-supplied geometry.

8.13 *Films and Sheet Materials*—Films and sheet materials shall be tested in the as-supplied geometry. (Adhesive films shall be cured and used as in 8.8.)

8.14 *Foams*—Foams supplied as sheet stock shall be tested in the as-supplied thicknesses. Sample dimensions shall be selected so as to have a surface area to volume that is representative of the application and to minimize edge effects. Foams supplied as castable curing materials shall be tested in accordance with 8.8. Excess cured foam shall be trimmed from the top of the tube.

8.15 *Grease, Lubricants, and Liquids*—Grease, lubricants, and liquids shall be placed in a 25-mm-diameter, nonoutgassing (for example, aluminum) dish-type holder, to a depth of approximately 3 mm. The dish-type holder is then placed in the effusion cell. The holder shall maintain a constant exposed liquid surface area during the evaporation process.

8.16 *Lacing Tape and Cord Cable Ties*—Lacing tape and cord cable ties shall be tested in the as-supplied geometry.

8.17 *Laminates and Circuit Boards*—Laminates and circuit boards shall be tested in the as-supplied geometry. A sample size of approximately 40 by 40 mm is acceptable. The presence and orientation of reinforcements affects diffusion rates. Outgassing from resin-rich surfaces predominates during the initial period. Then, diffusion may occur parallel to fiber paths; thus, laminate edge effects may be important, especially in thick samples. Distance to a free surface is an important consideration. If anisotropy exists, prepare a special sample holder to constrain the outgassing flow appropriately.

8.18 *Paint, Ink, Lacquers, and Varnishes*—Paint, lacquers, varnishes, and similar coatings shall be applied to a nonoutgassing substrate, for example, aluminum foil (see 6.2). Cut the substrate into sections small enough to stack in the effusion cell. Do not pack tightly so that diffusion between layers affects the results.

8.19 *Potting Compounds*—Potting compounds shall be cast in accordance with 8.8 to constrain the internal diffusion flow to the surface to one dimension.

8.20 *Premolded Rubbers, Elastomers, and Molding Compounds*—Rubbers, elastomers, and molding compounds shall be tested in the as-received geometry. Sample surface