

# TECHNICAL SPECIFICATION



**Information technology – Generic cabling systems for customer premises –  
Part 9903: Matrix modelling of channels and links**

**(standards.iteh.ai)**

[ISO/IEC TS 11801-9903:2021](https://standards.iteh.ai/catalog/standards/sist/0f80e5fb-8211-49f6-ad95-eccee2964e27/iso-iec-ts-11801-9903-2021)

<https://standards.iteh.ai/catalog/standards/sist/0f80e5fb-8211-49f6-ad95-eccee2964e27/iso-iec-ts-11801-9903-2021>



**THIS PUBLICATION IS COPYRIGHT PROTECTED**  
**Copyright © 2021 ISO/IEC, Geneva, Switzerland**

All rights reserved. Unless otherwise specified, no part of this publication may be reproduced or utilized in any form or by any means, electronic or mechanical, including photocopying and microfilm, without permission in writing from either IEC or IEC's member National Committee in the country of the requester. If you have any questions about ISO/IEC copyright or have an enquiry about obtaining additional rights to this publication, please contact the address below or your local IEC member National Committee for further information.

IEC Central Office  
3, rue de Varembe  
CH-1211 Geneva 20  
Switzerland

Tel.: +41 22 919 02 11  
[info@iec.ch](mailto:info@iec.ch)  
[www.iec.ch](http://www.iec.ch)

**About the IEC**

The International Electrotechnical Commission (IEC) is the leading global organization that prepares and publishes International Standards for all electrical, electronic and related technologies.

**About IEC publications**

The technical content of IEC publications is kept under constant review by the IEC. Please make sure that you have the latest edition, a corrigendum or an amendment might have been published.

**IEC publications search - [webstore.iec.ch/advsearchform](http://webstore.iec.ch/advsearchform)**

The advanced search enables to find IEC publications by a variety of criteria (reference number, text, technical committee, ...). It also gives information on projects, replaced and withdrawn publications.

**IEC online collection - [oc.iec.ch](http://oc.iec.ch)**

Discover our powerful search engine and read freely all the publications previews. With a subscription you will always have access to up to date content tailored to your needs.

**IEC Just Published - [webstore.iec.ch/justpublished](http://webstore.iec.ch/justpublished)**

Stay up to date on all new IEC publications. Just Published details all new publications released. Available online and once a month by email.

**Electropedia - [www.electropedia.org](http://www.electropedia.org)**

The world's leading online dictionary on electrotechnology, containing more than 22 000 terminological entries in English and French, with equivalent terms in 18 additional languages. Also known as the International Electrotechnical Vocabulary (IEV) online.

**IEC Customer Service Centre - [webstore.iec.ch/csc](http://webstore.iec.ch/csc)**

If you wish to give us your feedback on this publication or need further assistance, please contact the Customer Service Centre: [sales@iec.ch](mailto:sales@iec.ch).

**iTeh STANDARD PREVIEW**  
**(standards.iteh.ai)**

[ISO/IEC TS 11801-9903:2021](https://standards.iteh.ai/catalog/standards/sist/0f80e5fb-8211-49f6-ad95-eccee2964e27/iso-iec-ts-11801-9903-2021)

<https://standards.iteh.ai/catalog/standards/sist/0f80e5fb-8211-49f6-ad95-eccee2964e27/iso-iec-ts-11801-9903-2021>



# ISO/IEC TS 11801-9903

Edition 1.0 2021-03

## TECHNICAL SPECIFICATION



---

Information technology – Generic cabling systems for customer premises –  
Part 9903: Matrix modelling of channels and links

<https://standards.iteh.ai/catalog/standards/sist/0f80e5fb-8211-49f6-ad95-eccee2964e27/iso-iec-ts-11801-9903-2021>

INTERNATIONAL  
ELECTROTECHNICAL  
COMMISSION

ICS 35.200

ISBN 978-2-8322-9498-7

**Warning! Make sure that you obtained this publication from an authorized distributor.**

## CONTENTS

FOREWORD.....	5
INTRODUCTION.....	7
1 Scope.....	9
2 Normative references .....	9
3 Terms, definitions and abbreviated terms .....	9
3.1 Terms and definitions.....	9
3.2 Symbols and abbreviated terms .....	10
4 Matrix model.....	11
5 Matrix definition .....	11
5.1 General.....	11
5.2 Quadriports .....	11
5.3 Matrix port definition for a two-pair system representative for modelling purposes.....	11
5.4 Operational scattering matrix .....	12
5.5 General naming convention.....	12
5.6 S-matrix .....	13
5.7 Passivity .....	13
5.8 Operational reflection loss matrix.....	14
5.9 Transmission matrix (T-matrix).....	14
5.10 S-matrix of cabling.....	14
6 Calculation with matrices using limit lines .....	15
7 Extracting limit lines .....	15
8 General case using mixed-mode matrices .....	16
8.1 General.....	16
8.2 M-parameters .....	16
9 Submatrix DD .....	17
9.1 General.....	17
9.2 Equations to extract the cabling limit lines .....	17
9.2.1 General .....	17
9.2.2 Operational attenuation .....	17
9.2.3 Near-end crosstalk .....	17
9.2.4 Attenuation to far-end crosstalk ratio .....	17
9.2.5 Reflection (RL) .....	18
10 Component values to be used as input to the model .....	18
10.1 General.....	18
10.2 Cable .....	19
10.2.1 General .....	19
10.2.2 Wave attenuation.....	19
10.2.3 Near-end crosstalk .....	19
10.2.4 Far-end crosstalk.....	19
10.2.5 Reflection .....	20
10.3 Connections.....	21
10.3.1 General .....	21
10.3.2 As a point source of disturbance.....	21
10.3.3 As a transmission line.....	21
11 Submatrices CC, CD and DC.....	22

11.1	General.....	22
11.2	Submatrix CD .....	22
11.3	Submatrix DC .....	22
11.4	Submatrix CC .....	22
Annex A	(informative) Matrix conversion formulas.....	23
A.1	Overview.....	23
A.2	Formulas.....	23
A.2.1	Mixed-mode to T-matrix .....	23
A.2.2	T-matrix to M-matrix .....	23
A.2.3	Conversion matrices .....	23
Annex B	(normative) Channel and permanent link models for balanced cabling .....	25
B.1	General.....	25
B.2	Insertion loss .....	25
B.2.1	Insertion loss of the channel configuration .....	25
B.2.2	Insertion loss of the permanent link configurations.....	26
B.2.3	Assumptions for insertion loss .....	26
B.3	NEXT.....	27
B.3.1	NEXT of the channel configuration.....	27
B.3.2	NEXT of the permanent link configurations .....	27
B.3.3	Assumptions for NEXT.....	28
B.4	ACR-F .....	31
B.4.1	ACR-F of the channel configuration.....	31
B.4.2	ACR-F for the permanent link configurations.....	31
B.4.3	Assumptions for ACR-F.....	32
B.5	No Return loss.....	32
B.5.1	Return loss of the channel and permanent link configurations.....	32
B.5.2	Assumptions for the return loss circuit analysis method .....	33
B.6	PS ANEXT link modelling.....	36
B.6.1	General .....	36
B.6.2	PS ANEXT between connectors.....	36
B.6.3	PS ANEXT between cable segments .....	36
B.6.4	Principles of link modelling .....	36
B.7	PS AACR-F link modelling .....	37
B.7.1	General .....	37
B.7.2	PS AFEXT between connectors .....	37
B.7.3	PS AACR-F between cable segments .....	37
B.7.4	Principles of link modelling .....	37
B.7.5	Impact of PS AACR-F in channels and links with substantially different lengths .....	38
B.8	Component assumptions for modelling purposes.....	41
Annex C	(informative) Terms and definitions.....	43
C.1	Comparison of namings .....	43
C.2	General.....	44
C.3	Background of terms and definitions .....	44
C.3.1	Operational attenuation .....	44
C.3.2	Operational transfer function ( $T_B$ ).....	46
C.3.3	Image or wave transfer function ( $T$ ) .....	46
C.3.4	Insertion transfer function of a two-port ( $T_B$ ).....	46

C.3.5 Insertion transfer function ( $T_{BI}$ ) measured with a vector network analyser ..... 46

C.3.6 Operational reflection loss transfer function ( $T_{ref} = S_{ref}$ ) of a junction..... 46

Bibliography..... 48

Figure 1 – Link configurations of ISO/IEC 11801-1..... 7

Figure 2 – Matrix definition of a 4-port two twisted pair system ..... 12

Figure 3 – Operational scattering parameters example from port 2 ..... 12

Figure 4 – Transmission matrix concatenation showing an example of a 2-connector permanent link ..... 14

Figure 5 – Graphical example of a NEXT calculation showing statistical results (red) and final calculation (blue) ..... 16

Figure 6 – One pair M-matrix showing the submatrices ..... 16

Figure 7 – 100 m cable return loss without reflection at both ends ..... 20

Figure 8 – 100 m cable return loss with a reflection of 0,03 at both ends (6  $\Omega$  mismatch, ~23 dB return loss at 1 MHz)..... 21

Figure A.1 – X matrices ..... 24

Figure B.1 – Example of computation of NEXT with higher precision..... 28

Figure B.2 – Example of increased impact of PS AFEXT ..... 38

Figure C.1 – Defining the operational attenuation and the operational transfer functions of a two-port ..... 45

Figure C.2 – Defining the reflection transfer functions and the return loss of a junction..... 47

Table 1 – All four ports operational scattering parameter definition ..... 12

Table 2 – Equal S-parameters for real components..... 13

Table B.1 – Insertion loss deviation ..... 26

Table B.2 – Modelling assumptions for cable transmission parameters ..... 41

Table B.3 – Model input assumptions used in the statistical calculation (Class E<sub>A</sub>)..... 41

Table B.4 – Model input assumptions used in the statistical calculation (Class F<sub>A</sub>)..... 42

Table C.1 – Comparison of naming in ISO/IEC 11801-1 and ISO/IEC TS 11801-9903..... 43

STANDARD PREVIEW  
 (standards.iteh.ai)

<https://standards.iteh.ai/catalog/standards/sist/0f80a5fb-8211-49f6-ad95-ecccc2964e27/iso-iec-ts-11801-9903-2021>

## INFORMATION TECHNOLOGY – GENERIC CABLING SYSTEMS FOR CUSTOMER PREMISES –

### Part 9903: Matrix modelling of channels and links

#### FOREWORD

- 1) ISO (the International Organization for Standardization) and IEC (the International Electrotechnical Commission) form the specialized system for worldwide standardization. National bodies that are members of ISO or IEC participate in the development of International Standards through technical committees established by the respective organization to deal with particular fields of technical activity. ISO and IEC technical committees collaborate in fields of mutual interest. Other international organizations, governmental and non-governmental, in liaison with ISO and IEC, also take part in the work.
- 2) The formal decisions or agreements of IEC and ISO on technical matters express, as nearly as possible, an international consensus of opinion on the relevant subjects since each technical committee has representation from all interested IEC and ISO National bodies.
- 3) IEC and ISO documents have the form of recommendations for international use and are accepted by IEC and ISO National bodies in that sense. While all reasonable efforts are made to ensure that the technical content of IEC and ISO documents is accurate, IEC and ISO cannot be held responsible for the way in which they are used or for any misinterpretation by any end user.
- 4) In order to promote international uniformity, IEC and ISO National bodies undertake to apply IEC and ISO documents transparently to the maximum extent possible in their national and regional publications. Any divergence between any IEC and ISO document and the corresponding national or regional publication shall be clearly indicated in the latter.
- 5) IEC and ISO do not provide any attestation of conformity. Independent certification bodies provide conformity assessment services and, in some areas, access to IEC and ISO marks of conformity. IEC and ISO are not responsible for any services carried out by independent certification bodies.
- 6) All users should ensure that they have the latest edition of this document.
- 7) No liability shall attach to IEC and ISO or their directors, employees, servants or agents including individual experts and members of its technical committees and IEC and ISO National bodies for any personal injury, property damage or other damage of any nature whatsoever, whether direct or indirect, or for costs (including legal fees) and expenses arising out of the publication, use of, or reliance upon, this ISO/IEC document or any other IEC and ISO documents.
- 8) Attention is drawn to the Normative references cited in this document. Use of the referenced publications is indispensable for the correct application of this document.
- 9) Attention is drawn to the possibility that some of the elements of this ISO/IEC document may be the subject of patent rights. IEC and ISO shall not be held responsible for identifying any or all such patent rights.

ISO/IEC TS 11801-9903 has been prepared by subcommittee 25: Interconnection of information technology equipment, of ISO/IEC joint technical committee 1: Information technology. It is a Technical Specification.

This first edition of ISO/IEC TS 11801-9903 cancels and replaces ISO/IEC TR 11801-9903 published in 2015. This edition constitutes a technical revision.

This edition includes the following significant technical changes with respect to the previous edition:

- a) the addition of further clarifications of the relations of parameters described in this edition and referenced analogous parameters in IEC TR 62152, e.g. operational attenuation versus operational transfer loss;
- b) the introduction and description of the higher order M-parameters  $8 \times 8$  matrix of mixed-mode parameters, which includes the  $4 \times 4$  submatrix of 4-port differential-mode-to-differential-mode (DD) parameters, among three other submatrices of mixed-mode parameters;
- c) Annex A, matrix conversion formulas, covers up to 16-port parameters matrices;
- d) the expanded Annex B description of example calculations for channel and permanent link, and updated component parameter tables.

The list of all currently available parts of the ISO/IEC 11801 series, under the general title *Information technology – Generic cabling for customer premises*, can be found on the IEC and ISO web sites.

The text of this Technical Specification is based on the following documents:

Draft	Report on voting
JTC1-SC25/2959/DTS	JTC1-SC25/2993/RVDTS

Full information on the voting for its approval can be found in the report on voting indicated in the above table.

The language used for the development of this Technical Specification is English.

This document was drafted in accordance with ISO/IEC Directives, Part 2, and developed in accordance with ISO/IEC Directives, Part 1, available at [www.iec.ch/members\\_experts/refdocs](http://www.iec.ch/members_experts/refdocs).

**IMPORTANT – The 'colour inside' logo on the cover page of this publication indicates that it contains colours which are considered to be useful for the correct understanding of its contents. Users should therefore print this document using a colour printer.**

**(standards.iteh.ai)**

[ISO/IEC TS 11801-9903:2021](https://standards.iteh.ai/catalog/standards/sist/0f80e5fb-8211-49f6-ad95-eccee2964e27/iso-iec-ts-11801-9903-2021)

<https://standards.iteh.ai/catalog/standards/sist/0f80e5fb-8211-49f6-ad95-eccee2964e27/iso-iec-ts-11801-9903-2021>



## INTRODUCTION

The pass/fail limits for defined channel and permanent link cabling configurations have an implicit impact on the component limits for the cabling components used. The channel configurations and the link configurations are specified in ISO/IEC 11801-1:2017, Clause 6 and Clause 7, respectively.

The permanent link configurations, which represent the fixed portion of the cabling, have two possible topologies:

- a connection plus a segment of cable plus a connection (2-connector topology);
- a connection plus a segment of cable plus a connection plus another segment of cable plus another connection (3-connector topology).

The link configurations of ISO/IEC 11801-1 are shown in Figure 1.

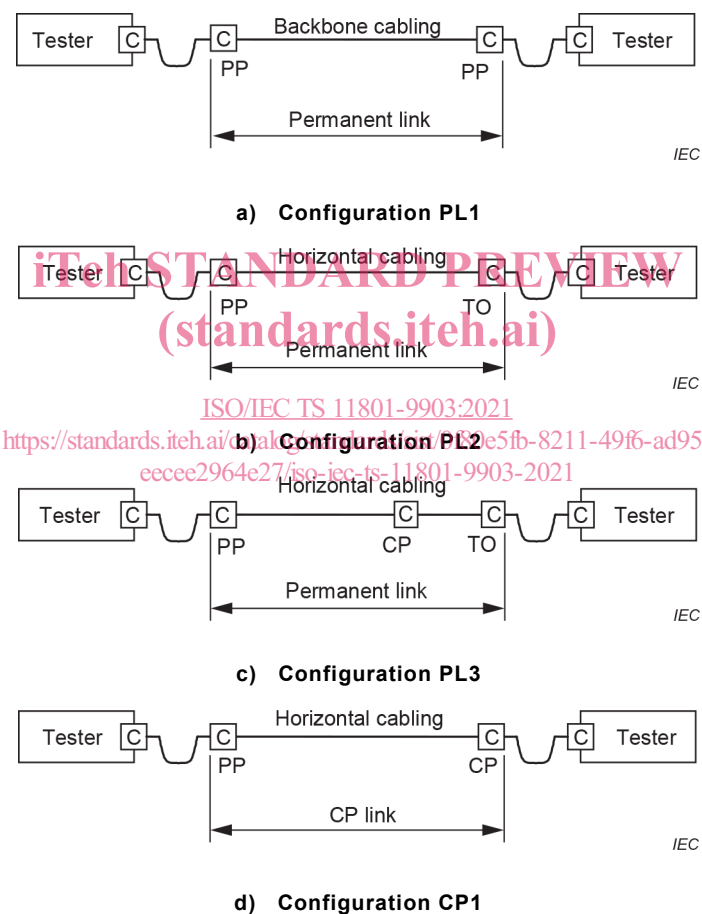

**Figure 1 – Link configurations of ISO/IEC 11801-1**

This document includes models and assumptions, which support pass/fail limits for the channel and permanent link test configurations in ISO/IEC 11801-1. These are based on the performance requirements of cable and connecting hardware as specified in IEC standards.

This document provides reasonable assurance that a channel created by adding compliant patch cords to a previously certified permanent link will meet the applicable channel performance limits.

Over the years the frequencies of the classes increased, but the theory for calculating the limits stayed the same. Especially the higher order effects had to be considered and in the end only by doing a Monte Carlo calculation, assuming that not all components would be at the limit at the same time, allowed compliance to be proved.

The model uses two pairs for all calculations. The limits are equal for pairs or pair combinations but in reality measured values could be different. If results are required that need more pairs to be considered, then this calculation can be done based on the results from multiple two-pair calculations with appropriate inputs (worst case). An example of such a calculation is the power sum and average limit lines for four pairs.

Symmetry and additional contributions that result from unbalanced signals and differential-to-common and common-to-differential mode coupling are included in this document by increasing the matrix size.

For details on the naming of transmission parameters, see Clause 3 and Clause C.1.

## iTeh STANDARD PREVIEW (standards.iteh.ai)

[ISO/IEC TS 11801-9903:2021](https://standards.iteh.ai/catalog/standards/sist/0f80e5fb-8211-49f6-ad95-eecee2964e27/iso-iec-ts-11801-9903-2021)

<https://standards.iteh.ai/catalog/standards/sist/0f80e5fb-8211-49f6-ad95-eecee2964e27/iso-iec-ts-11801-9903-2021>

# INFORMATION TECHNOLOGY – GENERIC CABLING SYSTEMS FOR CUSTOMER PREMISES –

## Part 9903: Matrix modelling of channels and links

### 1 Scope

This part of ISO/IEC 11801, which is a Technical Specification, establishes a matrix-model for formulating limits for mixed-mode parameters within and between two pairs of balanced cabling. This is for the purpose of supporting new, improved balanced cabling channel and link specifications.

### 2 Normative references

The following documents, in whole or in part, are normatively referenced in this document and are indispensable for its application. For dated references, only the edition cited applies. For undated references, the latest edition of the referenced document (including any amendments) applies.

ISO/IEC 11801-1, *Information technology – Generic cabling for customer premises – Part 1: General requirements*

(standards.iteh.ai)

### 3 Terms, definitions and abbreviated terms

#### 3.1 Terms and definitions

For the purposes of this document, the terms and definitions given in ISO/IEC 11801-1 and the following apply.

ISO and IEC maintain terminological databases for use in standardization at the following addresses:

- IEC Electropedia: available at <http://www.electropedia.org/>
- ISO Online browsing platform: available at <http://www.iso.org/obp>

#### 3.1.1

##### **attenuation**

diminishing of signal strength

Note 1 to entry: Details need to be added to indicate the exact usage.

#### 3.1.2

##### **connection**

two mated connectors

EXAMPLE Jack and plug.

#### 3.1.3

##### **image attenuation**

##### **wave attenuation**

attenuation when a two-port is terminated by its input and output characteristic impedances with no reflections at input and output

Note 1 to entry: The wave attenuation of cables is length scalable.

**3.1.4****insertion loss**

attenuation or loss caused by a two-port inserted into a system

**3.1.5****insertion loss deviation**

deviation of attenuation loss with regard to the wave attenuation due to mismatches or internal reflections

**3.1.6****operational attenuation**

ratio of the square root of the maximum available power wave vector emitted by the generator and the square root of the power wave vector absorbed by the load of the two-port

Note 1 to entry: The operational attenuation is not length scalable (see also C.3.1 and C.3.2).

Note 2 to entry: The operational attenuation is expressed in decibels (dB) and radians (rad).

**3.1.7****passivity**

property of an electrical system that the output power at all ports does not exceed the input power at all ports

**3.1.8****unitarity**

mathematical concept for matrices to define passivity

**3.1.9****operational reflection**

loss due to the reflection at a junction

Note 1 to entry: See also C.3.6.

ISO/IEC TS 11801-9903:2021  
<https://standards.iteh.ai/catalog/standards/sist/0f80e5fb-8211-49f6-ad95-eccee2964e27/iso-iec-ts-11801-9903-2021>

**3.2 Symbols and abbreviated terms**

For the purposes of this document, the symbols and abbreviated terms given in ISO/IEC 11801-1 and the following apply.

$f$	frequency (MHz)
RL	return loss limit (dB)
$\rho$	(rho) operational reflection transfer function, junction reflection coefficient
DRL	distributed return loss (dB)
IL	insertion loss limit (dB)
$A$	operational wave attenuation (Np)
$A_T$	operational wave transfer function (Np)
$B$	operational phase (rad)
$B_T$	operational phase transfer function (rad)
$B_{\text{RAND}}$	random phase (rad)
NEXT	operational near-end crosstalk loss limit (dB)
$\text{NEXT}_T$	operational near-end crosstalk transfer function (dB)
FEXT	operational far-end crosstalk loss limit (dB)
$\text{FEXT}_T$	operational far-end crosstalk transfer function (dB)

## 4 Matrix model

The model to be used is a concatenated matrix calculation as discussed in IEC TR 62152 [1]<sup>1</sup> for a 2-port system. For a 2-pair balanced cabling calculation, a 4-port differential matrix as shown in Figure 2 shall be used.

The model assumes that all components are specified with S-parameters and these parameters are used then to fill an S-matrix for every cabling component.

To concatenate components these S-matrices are transformed into transmission T-matrices which can then be multiplied in the appropriate order to simulate the transmission characteristics of the concatenated components (for details see IEC TR 62152:2009, Annex C).

To evaluate the transmission performance of the modelled channel or permanent link, the calculated T-matrix of the cabling is transformed back into an S-matrix providing the expected transmission parameters of the cabling system.

The matrix calculation is done mathematically with S-parameters in amplitude and phase.

- a) Measured S-parameters are usually known in amplitude and phase.
- b) Parameter limit lines for components and for cabling are specified in amplitude only, usually in decibel. For modelling purposes these amplitudes shall be transformed into a linear value.
- c) For the calculation of matrix terms representing limit lines, the phase is added as a random value to simulate power sum addition (see Clause 6).

## 5 Matrix definition

### 5.1 General

In Clause 5 only the part with the balanced components is described. For the unbalanced part see 8.2.

### 5.2 Quadriports

In IEC TR 62152 [1] voltage and currents of the input and output waves are specified for two ports. In Figure 2, Figure 3, Table 1, and Formula (1), the cabling specific notation needed for quadriports (two pairs) is detailed.

### 5.3 Matrix port definition for a two-pair system representative for modelling purposes

In Figure 2, a 4-port matrix is presented. The definition is one line per port per twisted pair.

---

<sup>1</sup> Numbers in square brackets refer to the Bibliography.

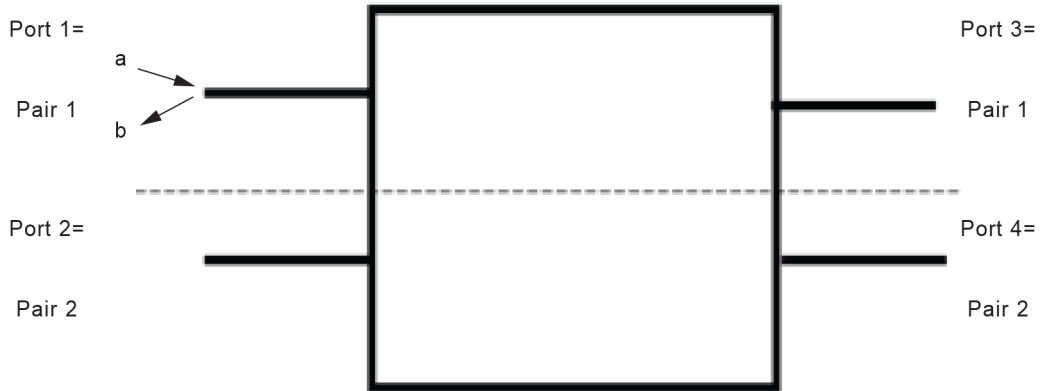

IEC

**Key**

- a designates a wave entering the quadriport
- b designates a wave leaving the quadriport

**Figure 2 – Matrix definition of a 4-port two twisted pair system**

**5.4 Operational scattering matrix**

In Figure 3, the S-parameters for a source at port 2 are shown. For all definitions, see 5.5.



IEC

**Key**

Definition of S-parameters:  $S_{output, input}$

$S_{12}$  = operational near-end crosstalk transfer function ( $NEXT_T$ )

$S_{22}$  = operational reflections coefficient ( $\rho$ )

$S_{32}$  = operational far-end crosstalk transfer function ( $FEXT_T$ )

$S_{42}$  = operational forward transfer function ( $A_T$ )

**Figure 3 – Operational scattering parameters example from port 2**

**5.5 General naming convention**

The naming convention for the four ports is given in Table 1.

**Table 1 – All four ports operational scattering parameter definition**

From Port 1:	From Port 2:	From Port 3:	From Port 4:
$S_{21} NEXT_T$	$S_{12} NEXT_T$	$S_{43} NEXT_T$	$S_{34} NEXT_T$
$S_{11} \rho$	$S_{22} \rho$	$S_{33} \rho$	$S_{44} \rho$
$S_{41} FEXT_T$	$S_{32} FEXT_T$	$S_{23} FEXT_T$	$S_{14} FEXT_T$
$S_{31} A_T$	$S_{42} A_T$	$S_{13} A_T$	$S_{24} A_T$

### 5.6 S-matrix

For each cabling component (for cables for each length and type involved, for connections for each type) an S-matrix needs to be developed, see Formula (1). The matrix numbering starts with 1 to be compatible with scattering parameters and generally used definitions (see 5.5) and IEC TR 62152.

$$S = \begin{bmatrix} S_{11} & S_{12} & S_{13} & S_{14} \\ S_{21} & S_{22} & S_{23} & S_{24} \\ S_{31} & S_{32} & S_{33} & S_{34} \\ S_{41} & S_{42} & S_{43} & S_{44} \end{bmatrix} \quad (1)$$

The following transmission parameters can be substituted into the matrix in Formula (1).

- $\rho$ :  $S_{11}, S_{22}, S_{33}, S_{44}$   
 NEXT<sub>T</sub>:  $S_{12}, S_{34}$   
 FEXT<sub>T</sub>:  $S_{14}, S_{23}$   
 $A_T$ :  $S_{13}, S_{24}$

The equal scattering coefficient due to symmetrical nature of component parameters results in the set of equalities in Table 2.

**Table 2 – Equal S-parameters for real components**

Parameter	Equality	For pair number(s)
$A_T$	$S_{13} = S_{31}$	1
$A_T$	$S_{24} = S_{42}$	2
FEXT <sub>T</sub>	$S_{14} = S_{41}$	1 and 2
FEXT <sub>T</sub>	$S_{23} = S_{32}$	1 and 2
NEXT <sub>T</sub>	$S_{21} = S_{12}$	1 and 2
NEXT <sub>T</sub>	$S_{34} = S_{43}$	1 and 2

The equalities provided in Table 2 apply to the component scattering matrix in Formula (1).

### 5.7 Passivity

There is a general assumption that all transmission parameter loss values, e.g. NEXT and FEXT, are much less than one, in linear value, or much greater than 0, in dB.

At higher frequencies this needs to be taken care of. Otherwise, the output power at ports in total can be calculated as being higher than the input power.

This is defined as passivity and should be implemented. An example is shown in 5.8.