**Dentistry — Casting and baseplate
waxes**

Médecine bucco-dentaire — Cires pour coulée et pour plaque de base

iTeh STANDARD PREVIEW
(standards.iteh.ai)

[ISO 15854:2023](https://standards.iteh.ai/catalog/standards/sist/b0330d88-c4e1-4929-a452-1b6f9cfa8c19/iso-15854-2023)

<https://standards.iteh.ai/catalog/standards/sist/b0330d88-c4e1-4929-a452-1b6f9cfa8c19/iso-15854-2023>



iTeh STANDARD PREVIEW
(standards.iteh.ai)

ISO 15854:2023

<https://standards.iteh.ai/catalog/standards/sist/b0330d88-c4e1-4929-a452-1b6f9cfa8c19/iso-15854-2023>



COPYRIGHT PROTECTED DOCUMENT

© ISO 2023

All rights reserved. Unless otherwise specified, or required in the context of its implementation, no part of this publication may be reproduced or utilized otherwise in any form or by any means, electronic or mechanical, including photocopying, or posting on the internet or an intranet, without prior written permission. Permission can be requested from either ISO at the address below or ISO's member body in the country of the requester.

ISO copyright office
CP 401 • Ch. de Blandonnet 8
CH-1214 Vernier, Geneva
Phone: +41 22 749 01 11
Email: copyright@iso.org
Website: www.iso.org

Published in Switzerland

Contents

	Page
Foreword.....	v
Introduction.....	vi
1 Scope.....	1
2 Normative references.....	1
3 Terms and definitions.....	1
4 Classification.....	2
5 Requirements.....	2
5.1 Appearance.....	2
5.2 Flow.....	2
5.3 Behaviour on trimming.....	3
5.4 Behaviour on softening — Type 1.....	3
5.5 Appearance after flaming.....	3
5.6 Behaviour on softening — Type 2.....	3
5.7 Residue on artificial teeth — Type 2.....	3
5.8 Behaviour of colouring material — Type 2.....	3
5.9 Adhesion on storage — Type 2.....	3
5.10 Residue on ignition — Type 1.....	3
5.11 Biocompatibility.....	3
6 Sampling.....	4
7 Test methods — General.....	4
7.1 Ambient temperature.....	4
7.2 Apparatus function verification.....	4
8 Test methods — Specific.....	4
8.1 Visual inspection.....	4
8.2 Flow.....	4
8.2.1 Principle.....	4
8.2.2 Apparatus.....	4
8.2.3 Preparation of test pieces.....	8
8.2.4 Procedure.....	9
8.2.5 Expression of results and evaluation.....	10
8.3 Behaviour on trimming test.....	11
8.3.1 Principle.....	11
8.3.2 Apparatus.....	11
8.3.3 Procedure.....	11
8.4 Behaviour on softening test — Type 1.....	11
8.4.1 Principle.....	11
8.4.2 Apparatus.....	11
8.4.3 Procedure.....	11
8.5 Appearance after flaming test.....	12
8.5.1 Principle.....	12
8.5.2 Procedure.....	12
8.6 Behaviour on softening test — Type 2.....	12
8.6.1 Principle.....	12
8.6.2 Apparatus.....	12
8.6.3 Procedure.....	12
8.7 Residue on artificial teeth and behaviour of wax colouring material test — Type 2.....	12
8.7.1 Principle.....	12
8.7.2 Apparatus.....	13
8.7.3 Procedure.....	13
8.8 Adhesion on storage test — Type 2.....	14
8.8.1 Principle.....	14

8.8.2	Apparatus	14
8.8.3	Procedure	14
8.9	Residue on ignition test— Type 1	15
8.9.1	Principle	15
8.9.2	Apparatus	15
8.9.3	Procedure	15
9	Marking and packaging	16
9.1	Marking	16
9.2	Packaging	16
10	Test report	16
Annex A (informative) Determination of the melting point of wax		18
Bibliography		20

iTeh STANDARD PREVIEW
(standards.iteh.ai)

[ISO 15854:2023](https://standards.iteh.ai/catalog/standards/sist/b0330d88-c4e1-4929-a452-1b6f9cfa8c19/iso-15854-2023)

<https://standards.iteh.ai/catalog/standards/sist/b0330d88-c4e1-4929-a452-1b6f9cfa8c19/iso-15854-2023>

Foreword

ISO (the International Organization for Standardization) is a worldwide federation of national standards bodies (ISO member bodies). The work of preparing International Standards is normally carried out through ISO technical committees. Each member body interested in a subject for which a technical committee has been established has the right to be represented on that committee. International organizations, governmental and non-governmental, in liaison with ISO, also take part in the work. ISO collaborates closely with the International Electrotechnical Commission (IEC) on all matters of electrotechnical standardization.

The procedures used to develop this document and those intended for its further maintenance are described in the ISO/IEC Directives, Part 1. In particular, the different approval criteria needed for the different types of ISO documents should be noted. This document was drafted in accordance with the editorial rules of the ISO/IEC Directives, Part 2 (see www.iso.org/directives).

Attention is drawn to the possibility that some of the elements of this document may be the subject of patent rights. ISO shall not be held responsible for identifying any or all such patent rights. Details of any patent rights identified during the development of the document will be in the Introduction and/or on the ISO list of patent declarations received (see www.iso.org/patents).

Any trade name used in this document is information given for the convenience of users and does not constitute an endorsement.

For an explanation of the voluntary nature of standards, the meaning of ISO specific terms and expressions related to conformity assessment, as well as information about ISO's adherence to the World Trade Organization (WTO) principles in the Technical Barriers to Trade (TBT), see www.iso.org/iso/foreword.html.

This document was prepared by Technical Committee ISO/TC 106, *Dentistry*, Subcommittee SC 2, *Prosthetic materials*, in collaboration with the European Committee for Standardization (CEN) Technical Committee CEN/TC 55, *Dentistry*, in accordance with the Agreement with the Agreement on technical cooperation between ISO and CEN (Vienna Agreement).

This third edition cancels and replaces the second edition (ISO 15854:2021), which has been technically revised.

The main changes compared with the previous edition are as follows:

- the scope has been clarified;
- waxes supplied for use in CAD/CAM procedures have been included;
- the appearance after flaming has been extended to include casting waxes.

Any feedback or questions on this document should be directed to the user's national standards body. A complete listing of these bodies can be found at www.iso.org/members.html.

Introduction

For the purposes of this document, the term 'casting' includes 'pressing', as used for glass ceramics.

It is recommended that, in assessing possible biological or toxicological hazards, reference be made to ISO 7405 and ISO 10993-1.

iTeh STANDARD PREVIEW
(standards.iteh.ai)

ISO 15854:2023

<https://standards.iteh.ai/catalog/standards/sist/b0330d88-c4e1-4929-a452-1b6f9cfa8c19/iso-15854-2023>

Dentistry — Casting and baseplate waxes

1 Scope

This document specifies the classification of and requirements for waxes used for dental casting (including products intended for CAD/CAM milling) using the lost-wax technique and dental baseplate preparation together with the test methods to be employed to determine compliance with these requirements.

Solid polymer products (such as acrylics) for CAD/CAM work, and thermoplastic or photo-curing resins used in additive processes, are not covered by this document.

This document does not include specific and quantitative requirements for freedom from biological hazards.

2 Normative references

The following documents are referred to in the text in such a way that some or all of their content constitutes requirements of this document. For dated references, only the edition cited applies. For undated references, the latest edition of the referenced document (including any amendments) applies.

ISO 1942, *Dentistry — Vocabulary*

ISO 21920-2, *Geometrical product specifications (GPS) — Surface texture: Profile — Part 2: Terms, definitions and surface texture parameters*

ISO 6873, *Dentistry — Gypsum products*
<https://standards.iteh.ai/catalog/standards/sist/b0330d88-c4e1-4929-a452-1b6f9cfa8c19/iso-15854-2023>

ISO 8601-1, *Date and time — Representations for information interchange — Part 1: Basic rules*

ISO 22112, *Dentistry — Artificial teeth for dental prostheses*

3 Terms and definitions

For the purposes of this document, the terms and definitions given in ISO 1942 and the following apply.

ISO and IEC maintain terminology databases for use in standardization at the following addresses:

— ISO Online browsing platform: available at <https://www.iso.org/obp>

— IEC Electropedia: available at <https://www.electropedia.org/>

3.1

casting wax

mouldable material with minimal residue on ignition suitable primarily for shaping patterns in the production of cast restorations using the *lost-wax technique* (3.5)

3.2

baseplate wax

mouldable material primarily for forming occlusion rims, positioning and retaining artificial teeth therein, and shaping patterns that are duplicated in the denture base polymer

3.3

milling wax

casting wax (3.1) where patterns are formed by milling using CAD/CAM systems

3.4 melting point

temperature above which no solid material exists at equilibrium

Note 1 to entry: For the practical purposes of this document, the melting point and the freezing point shall be considered as being the same.

3.5 lost-wax technique

method of casting using a wax pattern that is removed from the intact investment mould by melting or burning

4 Classification

Dental waxes covered by this document are classified according to the flow characteristics that represent their hardness, as follows:

a) Type 1 (casting wax, for lost-wax technique):

- 1) Class 1: Soft;
- 2) Class 2: Hard;
- 3) Class 3: Milling.

b) Type 2 (baseplate wax):

- 1) Class 1: Soft;
- 2) Class 2: Hard;
- 3) Class 3: Extra hard.

iTech STANDARD PREVIEW
(standards.iteh.ai)

ISO 15854:2023
<https://standards.iteh.ai/catalog/standards/sist/b0330d88-c4e1-4929-a452-1b6f9cfa8c19/iso-15854-2023>

5 Requirements

5.1 Appearance

The wax shall be uniform in colour, supplied in pieces of uniform size, of smooth texture and free of foreign materials. Test in accordance with [8.1](#).

5.2 Flow

The wax when tested in accordance with [8.2](#) shall have flow values conforming with the appropriate requirements in [Table 1](#).

Table 1 — Flow requirements percentages

Temperature °C	Type 1					Type 2					
	Class 1		Class 2		Class 3	Class 1		Class 2		Class 3	
	min.	max.	min.	max.	max.	min.	max.	min.	max.	min.	max.
23,0 ± 0,2	—	—	—	—	—	—	1,0	—	0,6	—	0,2
30,0 ± 0,2	—	1,0	—	—	—	—	—	—	—	—	—
37,0 ± 0,1	—	—	—	1,0	1,0	5,0	90,0	—	10,0	—	1,2
40,0 ± 0,1	50,0	—	—	20,0	20,0	—	—	—	—	—	—
45,0 ± 0,1	70,0	90,0	70,0	90,0	—	—	—	50,0	90,0	5,0	50,0
— not required											

5.3 Behaviour on trimming

The wax shall be capable of being trimmed without chipping, flaking or other undesirable behaviour when tested in accordance with [8.3](#).

5.4 Behaviour on softening — Type 1

The wax shall soften without flaking or crumbling and shall cohere readily when tested in accordance with [8.4](#).

5.5 Appearance after flaming

The wax shall present a smooth glossy surface when tested in accordance with [8.5](#).

5.6 Behaviour on softening — Type 2

The wax shall soften without becoming sticky or crumbly and shall be mouldable without breaking or delaminating when tested in accordance with [8.6](#).

This requirement shall not apply to baseplate preforms where a suitable square test piece cannot be cut.

5.7 Residue on artificial teeth — Type 2

The wax shall not leave a visible residue on either ceramic or synthetic polymer teeth when tested in accordance with [8.7](#).

5.8 Behaviour of colouring material — Type 2

The colouring material shall neither separate from the wax nor impregnate the gypsum mould when tested in accordance with [8.7](#).

5.9 Adhesion on storage — Type 2

Adhesion due to storage of the wax shall be such that, when tested in accordance with [8.8](#), there shall be no evidence of damage to wax surfaces. Wax and separating paper surfaces shall separate cleanly and readily.

NOTE The separating paper can possibly not cover the whole area of the wax sheet.

5.10 Residue on ignition — Type 1

If the manufacturer does not state a value for the residue on ignition, the value as determined in accordance with [8.9](#) shall be no greater than 0,10 % by mass.

If the residue on ignition is greater than 0,10 % by mass, this value shall be stated by the manufacturer and the value as determined in accordance with [8.9](#) shall be not more than 20 % greater than that stated value.

5.11 Biocompatibility

See ISO 7405 and ISO 10993-1 for guidance on compatibility in respect of waxes that are offered for use in the mouth or that are not specifically excluded from that application.

6 Sampling

The amount of material procured for testing shall be at least 250 g for Type 1 or 500 g for Type 2 from one batch and one packet where possible. This material shall be obtained on the open market unannounced and thus taken randomly from stock.

7 Test methods — General

7.1 Ambient temperature

Unless otherwise specified in this document, all test piece preparation and testing shall be conducted at an ambient temperature of (23 ± 2) °C. Where necessary and appropriate, all material shall be allowed to equilibrate at this ambient temperature before testing for at least 24 h.

7.2 Apparatus function verification

All accessories, instruments and equipment shall be examined before use to ensure that they are in acceptable working order, appropriately calibrated, and complying with specifications stated for them in this document, as appropriate.

8 Test methods — Specific

8.1 Visual inspection

Carry out the inspection at an illuminance of at least 1 000 lux and at a distance not exceeding 250 mm. A person making the inspection shall have nominally normal visual acuity. Corrective (non-magnifying) untinted lenses may be worn.

8.2 Flow

8.2.1 Principle

The relative change in length of the test piece under a given load in a specified time is taken as a proxy for the inverse of viscosity.

8.2.2 Apparatus

8.2.2.1 Micrometer screw gauge

Micrometer screw gauge with a range of at least 10 mm, being readable and accurate to 0,005 mm or better, equipped with flat, parallel anvils at least 6,5 mm in diameter and a non-rotating spindle.

Avoidance of indentation of the wax test piece is essential.

8.2.2.2 Flow-testing instrument

Flow-testing instrument, such as shown in [Figure 1](#), consisting of the following components:

- weight (see [Figure 1](#), Key 1);
- shaft, which can move freely in its supports, lubricated as necessary (see [Figure 1](#), Key 2);
- upper platen, metallic, minimum diameter 50 mm, lower surface flat and smooth, rigidly attached and normal to the axis of the shaft (see [Figure 1](#), Key 3);

- base plate, metallic, flat smooth and parallel to the lower surface of the upper platen (see [Figure 1](#), Key 4);
- measuring dial gauge or similarly functional instrument, with a range of at least 10 mm, readable and accurate to 0,005 mm or better, and rigidly supported (optional) (see [Figure 1](#), Key 5);
- locking screw or equivalent device (required if the dial gauge is used) (see [Figure 1](#), Key 6).

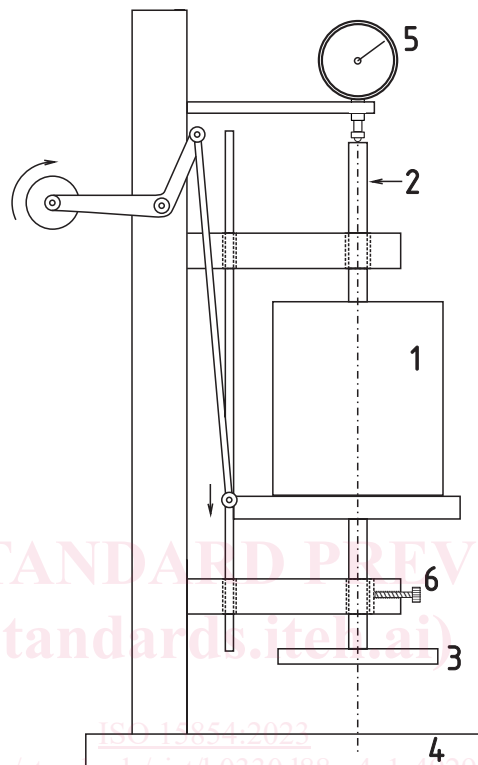

Key

- 1 weight
- 2 shaft
- 3 upper platen
- 4 base plate
- 5 dial gauge (optional)
- 6 locking screw

NOTE This figure is not to scale.

Figure 1 — Conceptual diagram of a suitable flow-testing instrument

The total mass of the components of items 1, 2 and 3 shall be such as to provide an axial compressive force of $(19,6 \pm 0,1)$ N. The weight ([Figure 1](#), Key 1) shall be separated from the surface of the water in the bath by at least 20 mm. The upper platen ([Figure 1](#), Key 3) shall be at least 5 mm thick for rigidity. The optional dial gauge ([Figure 1](#), Key 5) and locking screw ([Figure 1](#), Key 6) can replace the micrometer screw gauge for direct measurement of displacement (see [8.2.3](#)).

The axial force calculation shall take into account the buoyancy of the immersed parts of the shaft and upper platen (using the value of 0,01 N/ml) and the force exerted by the dial gauge or other measuring device ([Figure 1](#), Key 5), which force may be about 1 N and vary with its displacement if (as is usual) a spring is present. Appropriate control of the water level in the water bath ([8.2.2.9](#)) is required.

The locking screw or equivalent device shall not cause damage to the shaft ([Figure 1](#), Key 2) and thereby impede its free movement.