



Designation: E2141 – 12

# Standard Test Methods for Assessing the Durability of Absorptive Electrochromic Coatings on Sealed Insulating Glass Units<sup>1</sup>

This standard is issued under the fixed designation E2141; the number immediately following the designation indicates the year of original adoption or, in the case of revision, the year of last revision. A number in parentheses indicates the year of last reapproval. A superscript epsilon ( $\epsilon$ ) indicates an editorial change since the last revision or reapproval.

## 1. Scope

1.1 These test methods cover the accelerated aging and monitoring of the time-dependent performance of electrochromic glazings. Cross sections of typical electrochromic windows are shown in which devices have four or five-layers of coatings that include the two or three active layers sandwiched between transparent conducting electrodes (TCOs, see Section 3).

1.2 The test methods are applicable only for multilayered (two or more coatings between the TCOs) absorptive electrochromic coatings on sealed insulating glass (IG) units fabricated for vision glass (superstrate and substrate) areas for use in buildings, such as sliding doors, windows, skylights, and exterior wall systems. The multilayers used for electrochromically changing the optical properties may be inorganic or organic materials between the superstrate and substrate.

1.3 The electrochromic coatings used in this test method are exposed to solar radiation and are deployed to control the amount of radiation by absorption and reflection and thus, limit the solar heat gain and amount of solar radiation that is transmitted into the building.

1.4 The test methods are not applicable to other chromogenic devices, such as, photochromic and thermochromic devices.

1.5 The test methods are not applicable to electrochromic devices consisting of three layers of coatings including the two transparent conducting electrodes (see Section 3).

1.6 The test methods are not applicable to electrochromic windows that are constructed from superstrate or substrate materials other than glass.

1.7 The test methods referenced herein are laboratory tests conducted under specified conditions. These tests are intended to simulate and, in some cases, to also accelerate actual in-service use of the electrochromic windows. Results from

these tests cannot be used to predict the performance with time of in-service units unless actual corresponding in-service tests have been conducted and appropriate analyses have been conducted to show how performance can be predicted from the accelerated aging tests.

1.8 The values stated in SI units are to be regarded as the standard.

1.9 *This standard does not purport to address all of the safety concerns, if any, associated with its use. It is the responsibility of the user of this standard to establish appropriate safety and health practices and determine the applicability of regulatory limitations prior to use.*

## 2. Referenced Documents

### 2.1 ASTM Standards:<sup>2</sup>

- C168 Terminology Relating to Thermal Insulation
- C1199 Test Method for Measuring the Steady-State Thermal Transmittance of Fenestration Systems Using Hot Box Methods
- E122 Practice for Calculating Sample Size to Estimate, With Specified Precision, the Average for a Characteristic of a Lot or Process
- E631 Terminology of Building Constructions
- E892 Tables for Terrestrial Solar Spectral Irradiance at Air Mass 1.5 for a 37° Tilted Surface
- E903 Test Method for Solar Absorptance, Reflectance, and Transmittance of Materials Using Integrating Spheres
- E1423 Practice for Determining Steady State Thermal Transmittance of Fenestration Systems
- G113 Terminology Relating to Natural and Artificial Weathering Tests of Nonmetallic Materials

### 2.2 Canadian Standards:

- CAN/CGSB 12.8 Insulating Glass Units<sup>3</sup>

<sup>1</sup> This test method is under the jurisdiction of ASTM Committee E06 on Performance of Buildings and is the direct responsibility of Subcommittee E06.22 on Durability Performance of Building Constructions.

Current edition approved Nov. 15, 2012. Published January 2013. Originally approved in 2001. Last previous edition approved in 2006 as E2141 – 06. DOI: 10.1520/E2141-12.

<sup>2</sup> For referenced ASTM standards, visit the ASTM website, [www.astm.org](http://www.astm.org), or contact ASTM Customer Service at [service@astm.org](mailto:service@astm.org). For *Annual Book of ASTM Standards* volume information, refer to the standard's Document Summary page on the ASTM website.

<sup>3</sup> Available from Canadian General Standards Board (CGSB), Place du Portage III, 6B1 11 Laurier Street Gatineau, Quebec, Canada.

### 3. Terminology

3.1 *Definitions*—Refer to Terminology in **C168**, **E631**, and **G113** for descriptions of general terms.

3.2 *Definitions of Terms Specific to This Standard:*

3.2.1 *accelerated aging test*—an aging test in which the rate of degradation of building components or materials is intentionally accelerated from that expected in actual service.

3.2.2 *bleached state*—a descriptor for an EC coating when no ions reside in the electrochromic layer or after ions have been removed (or inserted, depending on the type of material) from the electrochromic layer(s) and if applicable, the maximum number of ions have been returned to the counterelectrode layer to restore the photopic specular transmittance in the bleached state ( $\tau_b$ ) from that of the photopic optical specular transmittance in the colored state ( $\tau_c$ ).

3.2.3 *colored state*—a descriptor for an EC coating after ions have been inserted (or removed, depending on the type of material) into the electrochromic layer and, if applicable, removed from the counterelectrode layer to reduce the photopic optical specular transmittance (of wavelengths from 400 nm to 730 nm) from that in the bleached state ( $\tau_b$ ).

3.2.4 *durability*—the capability of maintaining the serviceability of a product, component, assembly or construction over a specified time.

3.2.5 *electrochromic coating (ECC)*—the multilayered materials that include the electrochromic layers, other layers, and transparent conducting oxide layers required for altering the optical properties of the coating.

3.2.6 *electrochromic layer(s)*—the material(s) in an electrochromic coating (ECC) that alter its optical properties in response to the insertion or removal of ions, that is,  $\text{Li}^+$  or  $\text{H}^+$ .

3.2.7 *electrochromic glazing*—a device with an ECC consisting of several layers of electrochromic materials, attendant materials, and one or more lites of glass, which are able to alter their optical properties in response to a change in an applied electric field. The changeable optical properties include transmittance, reflectance, and absorptance.

3.2.8 *fenestration*—any opening in a building's envelope including windows, doors, and skylights.

3.2.9 *performance parameters*—the photopic transmittance ratio (PTR) ( $\text{PTR} = \tau_b/\tau_c$ ) between the bleached and colored states; coloring and bleaching times and open-circuit memory.

3.2.10 *serviceability*—the capability of a building product, component, assembly or construction to perform the function(s) for which it was designed and constructed.

3.3 For additional useful definitions for terminology used in this standard, see **Appendix X1**, **X1.2**.

### 4. Significance and Use

4.1 The test methods are intended to provide a means for evaluating the durability of ECCs as described in **1.2**.<sup>1,4</sup> (See **Appendix X1**).

### 5. Background

5.1 Durability is a critical requirement for an EC glazing product for use in the building envelope. In selecting the materials, device design, and glazing for any application, the ability of the glazing to perform over time is an indication of that glazing's durability. The purpose of this standard test method is to assess the durability of ECCs.

5.2 EC glazings perform a number of important functions in a building envelope including: minimizing the solar energy heat gain; providing for passive solar energy gain; controlling a variable visual connection with the outside world; enhancing human comfort (heat gain), security, ventilation, illumination, and glare control; providing for architectural expression, and (possibly) improving acoustical performance. Some of these functions may deteriorate in performance over time. Solar heat gain through an EC glazing is decreased because of two principal processes. Energy from the visible part of the spectrum is absorbed by an EC glazing in the colored state. In addition, infrared radiation is either absorbed by the EC glazing materials or is reflected by the transparent conducting oxide layers that are used for applying the coloring or bleaching potentials across the other layers in the EC glazing.

5.3 It is possible, but difficult to predict the time-dependent performance of EC glazings from accelerated aging tests because of the reasons listed below. Users of this document should be aware of these limitations when reviewing published performance results and their connection to durability.

5.3.1 The degradation mechanisms of ECC materials or glazings, or both, are complex. In some cases, however, these mechanisms may be determined and quantified.

5.3.2 The external factors that affect the performance of EC IGUs are numerous and may be difficult to quantify. However, in some cases, the use, the environmental factors, and other information that influence performance may be known.

5.3.3 Fenestration units with tested ECCs may be different from those planned for use in service. Some companies have a database of in-service performance that can be compared to laboratory results.

5.4 Degradation factors (or stresses) for EC IGUs include the ion insertion and removal processes; temperature; solar radiation (especially UV); water vapor; atmospheric gases and pollutants; thermal stresses such as shock from sudden rain, as well as during the diurnal and annual temperature cycles; electrochemically induced stresses in the multilayer thin-film device; hail, dust, and wind; condensation and evaporation of water; and thermal expansion mismatches<sup>4</sup>. These factors may singularly or collectively limit the stability and durability of EC IGUs. Because the EC IGUs are expected to have the multilayer of coatings on one of the surfaces in the air space of double-pane or triple-pane IG units with an inert gas fill in the sealed space, many factors such as high humidity, atmospheric

<sup>4</sup> A. W. Czanderna, D. K. Benson, G. J. Jorgensen, J-G. Zhang, C. E. Tracy, and S. K. Deb, "Durability Issues and Service Lifetime Prediction of Electrochromic Windows for Buildings Applications," NREL/TP-510-22702, May 1997, National Renewable Energy Laboratory, Golden, CO; Solar Energy Materials and Solar Cells, 56 (1999) pp. 419-436.

gases and pollutants, condensation and evaporation of water, and dust should not affect the durability of electrochromic coatings in IG units.

5.4.1 Establishing test procedures from which EC glazing durability can be predicted and validated for in-service use is extremely important. Because no uniformly accepted procedures or methods have been established for the real-time testing of EC IGUs and because manufacturers and users cannot wait 20 or more years for the real-time evaluation of each window design, accelerated life testing (ALT) methods and procedures must be used for evaluating EC glazing stability<sup>4</sup>. These include (a) rapid but realistic current-voltage (I-V) cyclic tests emphasizing the electrical properties, (b) ALT parameters that are typically used in durability tests by standards organizations, (c) ALT parameters that are realistic for the intended use of large-area EC IGUs, and (d) how the ALT results must be related to real-time testing. The purpose of this test method is to assess the durability of EC IGUs (at least  $250 \pm 6 \text{ mm} \times 250 \pm 6 \text{ mm}$ ).

NOTE 1—Caution—The seals in IGUs may fail at lower temperatures than those planned for testing, that is, 70 to 105°C. A seal failure will virtually guarantee failure of the EC coating, so no assessment of the EC coating will be made if a seal fails during a test.

NOTE 2—the test method may also be used for smaller EC glazings to assess the durability of prototype devices. The testing parameters chosen only provide modest acceleration factors. However, the quantitative parameters discussed in (a)–(c) above are presented and include a detailed description of the procedures for using an accelerated weathering unit (AWU) (See Practice E122).

6. Apparatus (See Figs. 1 and 2 and Section 8.3 for De-

scriptive Detail)

6.1 *Accelerated Weathering Unit (AWU)* consisting of properly filtered xenon-arc lamps to simulate over the applicable degradative wavelength region (UV plus visible) at least one-sun of solar irradiance at AM 1.5 (global) at sea level (E892), a controlled temperature chamber, and humidity control in the chamber.

6.2 *Voltage Cycling Unit* for imposing voltage cycles to alternately and repeatedly color and bleach the EC IGUs from a fully bleached state to the colored state and back to the bleached state.

6.3 *Computer Controlled Photodiode Array Spectrophotometer* that is, for obtaining and storing data from the electro-optical characterization of the optical transmittance in the colored and bleached state and measuring the rate of coloring and bleaching.

6.4 *Oven* that is large enough for the largest EC IGU to be tested and that can reach the EC IGU testing temperature. The oven must also be designed to permit using the equipment in 6.3 for optical measurements while the EC IGU is maintained at the temperature chosen for testing in the AWU described in 6.1.

6.5 *Tungsten Lamp*. A spectrum from the source must be compatible with the fiber optic illumination of the photodiode array spectrophotometer described in 6.3.

6.6 *Digital Camera*.

6.7 *Video Camera and Recorder*.

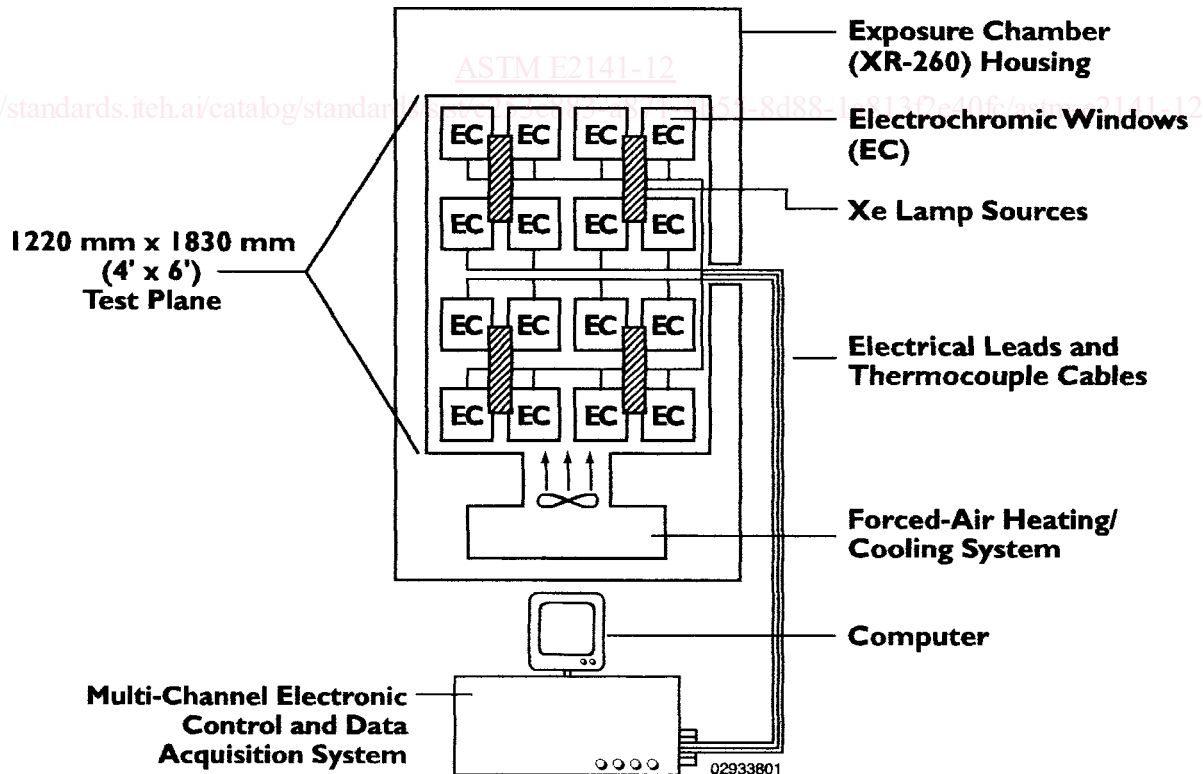
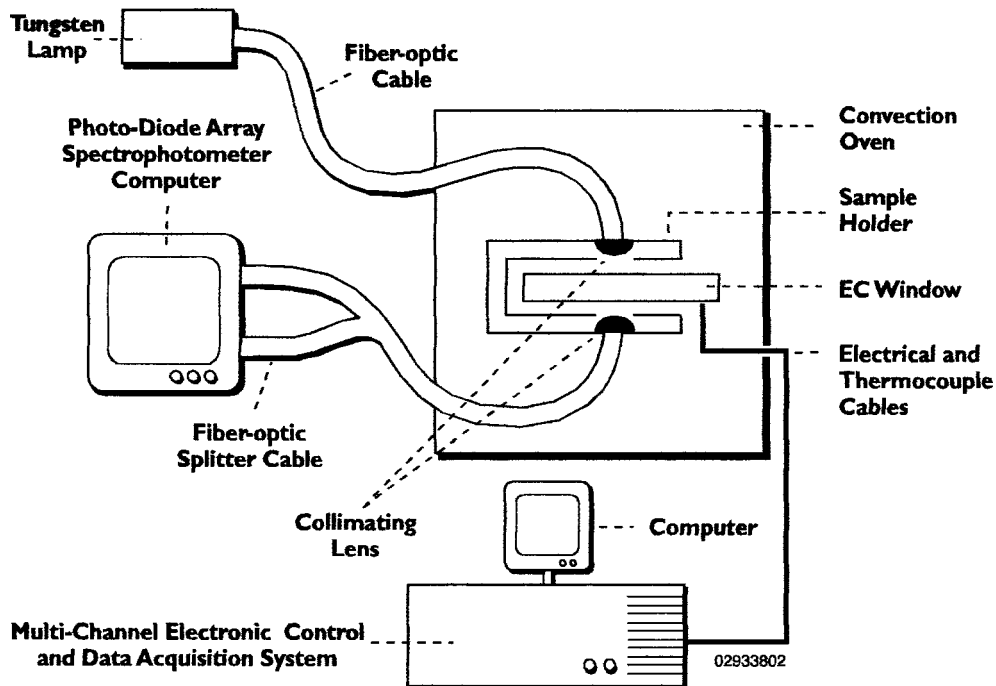

FIG. 1 Top-View Schematic Diagram of the Essential Components of an Environmental Test Chamber and Computer-Controlled Electrical Cycling and Data Acquisition System for Accelerated Weathering of Electrochromic Devices



Note: The measurements are used to determine the photopic transmittance ratio and record electro-optic degradation data after cyclic testing in the accelerated weathering unit.

**FIG. 2 Schematic of the (Essential) Elements of the Electro-Optic Measurement System Used for Recording 300–1100 Nm Transmittance Spectra for a Color/Bleach Cycle of EC Devices at Controlled Temperatures**

6.8 *Calibrated Thermocouples.*

6.9 *Electrical Leads* from the Unit in 6.2 to each EC IGU in the AWU described in 6.1.

**7. Test Specimens**

7.1 Test specimen size, design, and construction shall be established and specified by the user of this standard, except the specimens shall be at least  $250 \pm 6 \text{ mm} \times 250 \pm 6 \text{ mm}$ .

7.2 Six to 10 test specimens that are represented to be “identical” shall be the minimum number used to assess the durability of a particular design and construction. (See Item 2 in Appendix X1).

**8. Procedure**<sup>5</sup>

8.1 *Overview.* Expose the EC IGUs to simulated solar irradiance in a temperature- and humidity-controlled chamber at selected sample temperatures ranging from 70°C to 105°C while the ECWs are cyclically colored and bleached with the ability to pause during the duty cycles, depending on the control strategy prescribed by the manufacturer. The “testing” temperature shall be that of the EC coated lite in the colored state; the average EC IGU temperature will be less because of a typical decrease of about 5°C when the EC IGU is in the bleached state. Accept the prevailing relative humidity in the chamber (that is, 5 % to 20 %) because the prototype multi-layer coatings will be sealed inside double-pane or triple-pane

IG units for in-service use. Measure transmittances in a manner analogous to that described in E903.

8.2 *Electro-optical Characterization of EC IGUs* is accomplished by using a computer-controlled, multichannel potentiostat and a photodiode array spectrophotometer. The optical transmittance of all EC IGUs is initially measured at room temperature (ca. 22°C), as shown schematically in Fig. 2. The fiber optic cables are routed from the tungsten lamp source into the EC IGU sample holder. The convection oven shown in Fig. 2 is simply allowed to equilibrate with room temperature for measurements at ca. 22°C. The temperature of the EC IGU is monitored by a thermocouple (or other appropriate surface temperature probe or device) attached to the exterior facing surface of the EC coated lite which faces the xenon-arc lamps with a highly reflective tape (for example, aluminum or silver) having an emissivity close to that of glass. One optical fiber guides the incident light from the tungsten lamp to one side of the sample; another optical fiber guides the transmitted light to the photodiode array spectrometer attached to a computer. The fibers shall be optically coupled by properly aligned collimating lens assemblies attached to both the illuminating and the collection fibers. Reference spectra for 100 % and 0 % transmittance are taken before each measurement. The magnitudes of the coloring and bleaching voltages (typically <3 volts), as specified by the EC glazing manufacturer, are then applied. To minimize degradation caused by large current surges that occur at the beginning of the coloring or bleaching process, a trapezoidal voltage (ramp rate – 0.05 V/s) instead of a step voltage may be used. A typical voltage (V) waveform and the corresponding current (i) are plotted in Fig. 3 as a function of time. The optical transmittance of the sample is measured over

<sup>5</sup> The procedure is based in part on the paper by A. Czanderna, et al., in “Optical Materials Technology for Energy Efficiency and Solar Energy Conversion XV,” C. M. Lampert, C. Granqvist, M. Grätzel, and S. K. Deb, eds., SPIE Vol. 3138, 68 (1997).

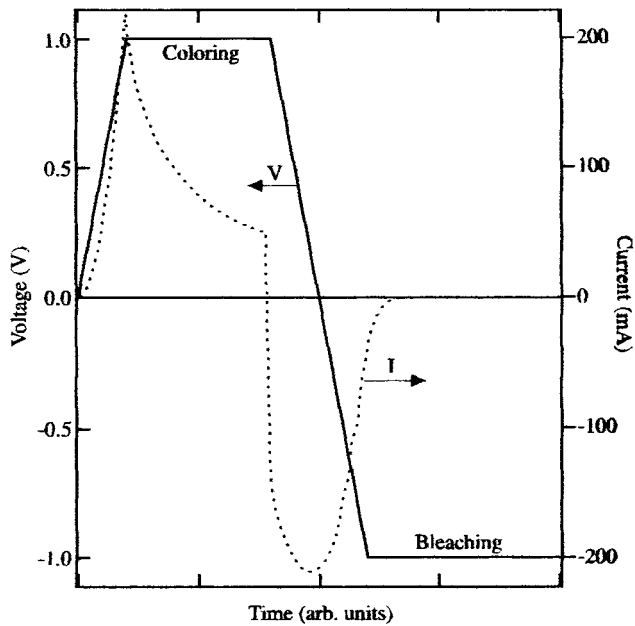

FIG. 3 Voltage and Current as a Function of Time During Coloring and Bleaching Processes for a Typical EC IGU

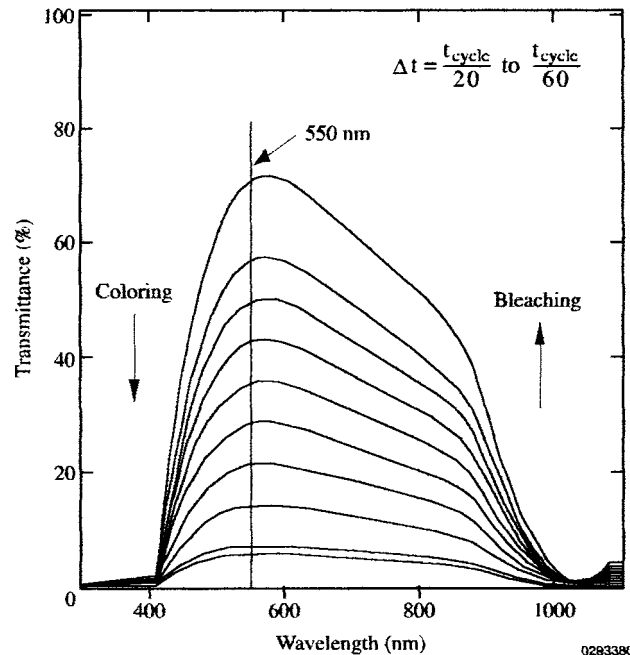

FIG. 4 Transmittance Spectra During a Coloring and Bleaching Process at Intervals Ranging from  $t_{\text{cycle}}/20$  to  $t_{\text{cycle}}/60$  for a Typical EC IGU

an appropriate spectral range in successive intervals during the coloring and bleaching processes. The time interval between the recorded spectra can be as small as one second. In typical testing experiments, a time interval of a fraction of the total cycle time for taking each spectrum should be adequate for recording the optical properties of each EC IGU, that is, for  $t_{\text{cycle}} = t_c + t_b$ , spectra taken at time intervals between  $t_{\text{cycle}}/20$  to  $t_{\text{cycle}}/60$  will probably be adequate. Typical transmittance spectra recorded during a coloring and bleaching cycle are shown in Fig. 4, in which the optical spectra of the devices are plotted as a function of wavelength. The time constants used in the voltage profile are determined by monitoring the time to reach an optical PTR ( $\tau_b/\tau_c$ ) of 5 at 550 nm. The photopic transmittance of the devices can be obtained by integrating the spectra in the wavelength range of 400 to 730 nm using the spectral photopic efficiency  $I_p(\lambda)$  (CIE, 1924) as the weighting factor<sup>6</sup> (see also E1423, C1199, CAN/CGSB 12.8).

8.2.1 A trapezoidal voltage profile similar to the one used at room temperature (ca. 22°C) is also used for the long-term cycling tests at temperatures ranging from 70°C to 105°C. Each EC IGU is heated in a convection oven at T and the coloring and bleaching times are determined for obtaining the specified PTR, that is, 5 at 550 nm. These data are then used to program the multichannel potentiostat with specific voltage profiles (for each device type) for cyclic testing at T in the AWU. After cycling for the desired time period, (for example, 4,000 to 10,000 cycles), the samples are cooled to room temperature and removed from the AWU. These samples are then electro-optically re-characterized at room temperature (ca. 22°C) using the voltage profile determined temperature (ca.

22°C) during the pretest procedure and compared to the initial values as shown in Fig. 4. The initial photopic transmittance for a typical EC IGU is shown in Fig. 5 as open circles, and the open squares and solid-circles indicate the typical photopic transmittance of an EC IGU at 22°C after 5,000 and 10,000 cycles at an elevated temperature, respectively.

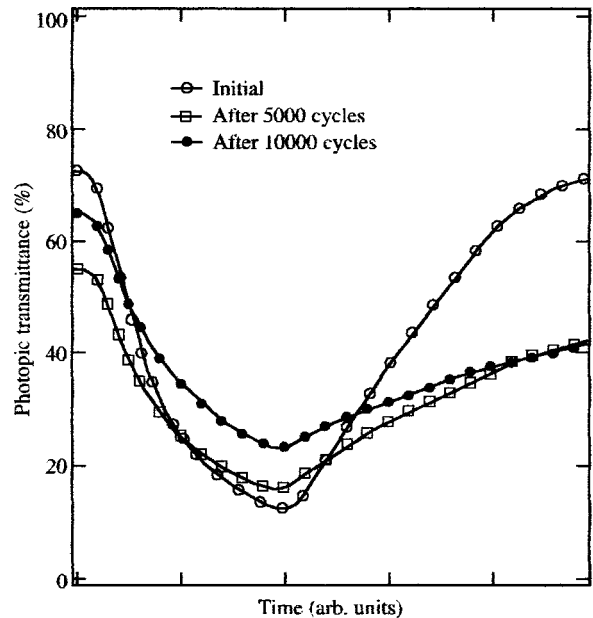

FIG. 5 Photopic Transmittance as a Function of Time Measured at Various Stages of Cycling of a Typical EC IGU

<sup>6</sup> R. Kingslake, "Applied Optics and Optical Engineering," in Vol. 1, *Light: Its Generation and Modification*, Academic Press, New York, NY, 1965, Table II, Chapter 1.

8.3 *Accelerated Weathering Environmental Exposure Chamber and Irradiance Calibration.* Fig. 1 shows a top-view schematic diagram of the essential features of using the environmental test chamber including the layout of the ECWs on a 1220 mm x 1830 mm test plane, the location of four xenon-arc lamps above the test plane, and the necessary connecting cables from the EC IGUs to the computer-controlled cycling and data acquisition system. (The XR-260 is 2440 mm high, 2650 mm deep, and 4480 mm (14.7 ft) wide and is specifically designed for indoor accelerated weathering tests of large samples.) The test plane is vertically adjustable and the user should adjust the distance from the lamps to the sample to obtain the desired light intensity and lateral uniformity within the guidelines of this document. Conditions inside the closed space can be controlled for temperatures from  $-40^{\circ}\text{C}$  to  $95^{\circ}\text{C}$  and relative humidities ranging from 5 % to 95 %. Temperature and relative humidity control within the test chamber are provided with a humidifier and by an integral forced-air heating and cooling system. Simulated solar irradiance is provided by four spectrally filtered and water-cooled 6500-W, long-arc xenon lamps housed within a reflector system in the ceiling of the test chamber. The EC IGUs are located on the vertically moveable test plane beneath the xenon lamps. Monitoring of the coloring and bleaching processes and of the sample temperatures are accomplished with a computerized electronic control and data acquisition system via 9 m long cables through access ports in the rear chamber wall.

8.3.1 The xenon lamps are powered to yield roughly a 1-sun illumination at the sample exposure plane from 290 nm through 600 nm. The lamps at these wavelengths shall be suitably filtered to provide an excellent match of an AM 1.5 solar spectrum from 300 nm to 900 nm (See Note 3.). The water-cooled lamps are surrounded by an inner IR-absorbing filter and an outer IR-absorbing filter, which prevent an excessive heat load. Calculate the total accumulated energy dose. For example, the AM 1.5 irradiance of 1-sun in 24 h yields the equivalent of a total accumulated solar energy dose of  $86.4 \text{ MJ/m}^2$  ( $2,592 \text{ MJ/m}^2$  per 30-day month) to each of the EC IGU samples. The four Xe lamps are typically operated at about 5400 W. At this power, the filters and lamps only need to be replaced after about 2000 h of operation. Adjust the chamber temperature to obtain the desired surface temperature of the EC IGU. For example, with a chamber air temperature of  $60 \pm 1^{\circ}\text{C}$ , the average EC IGU surface temperature reaches a steady-state temperature of about  $85 \pm 1^{\circ}\text{C}$  depending on the sample size, optical PTR-ratio reached during voltage cycling, location of the device in the test plane, and the EC IGU construction. When the relative humidity is not controlled during testing, it may range from 5 % to 20 % at a  $60^{\circ}\text{C}$  chamber temperature.

NOTE 3—At longer wavelengths, the fit to the solar spectrum is at variance with the AM 1.5 spectrum because of thermal emission lines associated with the xenon-arc lamp, but this part of the spectrum is generally not an important cause of photolytically induced degradation.

8.3.2 The remainder of this section is a description of a suitable procedure for deducing the spatial uniformity of the

irradiance in the test plane<sup>7</sup>. A uniformity measurement system (UMS) can be constructed using a thick aluminum plate as a base that is 610 mm x 1220 mm x 3.2 mm. Sensors can be mounted in a 305 mm center-to-center spacing scheme with a 3-row, 5-column configuration. To reduce adverse heating effects, all sensors should be spaced about 3 mm above the plate to allow for proper air circulation around the entire device. The plate itself should be painted flat black to minimize return reflections. The sensors are connected via a multiconductor data cable to an electronic enclosure that houses 15 miniature digital panel meters (DPM). Calibration is achieved by referencing all the sensors to a pyranometer under natural daylight conditions. All DPM readouts are then adjusted to agree with the PSP at a 1-sun ( $1000 \text{ W/m}^2$ ) reading, which typically results in a normal absolute error of about  $\pm 3 \%$  and a maximum uncertainty of  $\pm 5 \%$ .

8.3.3 The procedure for determining the irradiance in the test plane then involves laying the UMS assembly inside the AWU (that is, an XR-260) chamber on the test plane, with the sensors facing the xenon lamps. External connections are made to the DPM enclosure via the multiconductor data cable through the access port to the chamber. The chamber is then set to operate at  $25^{\circ}\text{C}$  and a relative humidity of 20 %. These are arbitrary operating set points because no defined procedures or specifications exist for calibrating solar simulator lamps. The Li-C or sensors used are not recommended for an absolute calibration measurement because of their slow response time and limited wavelength response. However, the procedure permits approximating the relative spectral uniformity across a defined test plane even though the absolute values are not known.

8.3.4 Once the chamber has reached the set-points, the lamps are ignited at 5400 W and are allowed to stabilize for whatever length of time the manufacturer recommends, which is usually 3 to 7 min. While watching the DPM readouts, the test-plane height is raised or lowered until the DPM readings average 1-sun ( $\sim 1000 \text{ W/m}^2$ ). The DPM readouts will not agree with each other unless the intensity is the same at all positions; the uniformity differences in the test plane are readily apparent. The procedure from this point is to adjust the lamp intensity or reflectors, or both, to improve uniformity of the lateral intensity within the desired area in the test plane. This is done by noting the readings until they agree as close as possible with each other but produce an overall lateral uniformity of  $\pm 8 \%$ .

8.3.5 Depending on the size of the desired test-plane area, the sensor plate is moved incrementally up or down, or left or right, for the number of measurements desired to establish the test-plane uniformity. The uniformity in the test-plane area is typically  $\pm 7 \%$  to  $8 \%$ .

8.4 *Mounting EC IGUs in the AWU Test Chamber.* Each manufacturer of ECWs must provide the coloring and bleaching voltages for room temperature characterization and for

<sup>7</sup> A description of a recently improved procedure is given in Appendix 1.