



Designation: **F1043 – 11a F1043 – 12**

Standard Specification for Strength and Protective Coatings on Steel Industrial Fence Framework¹

This standard is issued under the fixed designation F1043; the number immediately following the designation indicates the year of original adoption or, in the case of revision, the year of last revision. A number in parentheses indicates the year of last reapproval. A superscript epsilon (ϵ) indicates an editorial change since the last revision or reapproval.

1. Scope

1.1 This specification covers the strength and protective coating requirements for industrial steel fence framework. The intended use is for all types of fence, including but not limited to, chain link, expanded metal, wire mesh both welded and woven, PVC and wood. Consult fencing product manufacturer for post spacing requirements. Post spacings for chain link fence are not to exceed 10 ft. (For additional information, see CLFMI Guide WLG2445.)

1.1.1 *Caution Regarding Windload*—If additives to the fence, such as windscreen, inserts, or signage are required, it is advisable to use stronger framework and fittings, to reduce the on-center spacing of posts, or to add back bracing. Factors to consider when determining windload include the type of screening material to be used, area of fence to be covered and local wind conditions.

1.2 Posts and rails may have any cross-sectional shape meeting the requirements herein. The shapes may be formed and welded, cold formed, hot rolled, or extruded.

1.3 The values stated in inch-pound units are to be regarded as the standard. The values stated in SI units are for information purposes only; given in parentheses are mathematical conversions to SI units that are provided for information only and are not considered standard.

2. Referenced Documents

2.1 ASTM Standards:²

- [A90/A90M Test Method for Weight \[Mass\] of Coating on Iron and Steel Articles with Zinc or Zinc-Alloy Coatings](#)
- [A123/A123M Specification for Zinc \(Hot-Dip Galvanized\) Coatings on Iron and Steel Products](#)
- [A653/A653M Specification for Steel Sheet, Zinc-Coated \(Galvanized\) or Zinc-Iron Alloy-Coated \(Galvannealed\) by the Hot-Dip Process](#)
- [A924/A924M Specification for General Requirements for Steel Sheet, Metallic-Coated by the Hot-Dip Process](#)
- [A1011/A1011M Specification for Steel, Sheet and Strip, Hot-Rolled, Carbon, Structural, High-Strength Low-Alloy, High-Strength Low-Alloy with Improved Formability, and Ultra-High Strength](#)
- [B6 Specification for Zinc](#)
- [D1499 Practice for Filtered Open-Flame Carbon-Arc Exposures of Plastics](#)
- [D3359 Test Methods for Measuring Adhesion by Tape Test](#)
- [E8 Test Methods for Tension Testing of Metallic Materials](#)
- [E376 Practice for Measuring Coating Thickness by Magnetic-Field or Eddy-Current \(Electromagnetic\) Testing Methods](#)
- [F552 Terminology Relating to Chain Link Fencing](#)
- [F934 Specification for Colors for Polymer-Coated Chain Link Fence Materials](#)
- [F1083 Specification for Pipe, Steel, Hot-Dipped Zinc-Coated \(Galvanized\) Welded, for Fence Structures](#)
- [F1553 Guide for Specifying Chain Link Fence](#)
- [G155 Practice for Operating Xenon Arc Light Apparatus for Exposure of Non-Metallic Materials](#)

2.2 Other Documents:

- [WLG2445 CLFMI Guide for the Selection of Line Post Spacings³](#)

¹ This specification is under the jurisdiction of ASTM Committee F14 on Fences and is the direct responsibility of Subcommittee F14.40 on Chain Link Fence and Wire Accessories.

Current edition approved June 1, 2011; Nov. 15, 2012. Published June 2011; December 2012. Originally approved in 1995. Last previous edition approved in 2011 as F1043 – 11; F1043 – 11a. DOI: 10.1520/F1043-11A; 10.1520/F1043-12.

² For referenced ASTM standards, visit the ASTM website, www.astm.org, or contact ASTM Customer Service at service@astm.org. For *Annual Book of ASTM Standards* volume information, refer to the standard's Document Summary page on the ASTM website.

³ Available from Chain Link Fence Manufacturers Institute, 10015 Old Columbia Road, Suite B-215, Columbia, MD 21046, <http://www.chainlinkinfo.org>.

3. Terminology

3.1 Definitions:

3.1.1 *posts*—vertical members of the fence.

3.1.1.1 *Discussion*—

End, corner, and pull posts are posts at which fencing material terminates. Gateposts are posts to which gates are either attached or latched. Line posts are posts that occur in a line of fence in which the fencing material passes and to which it is secured.

3.1.2 *rails*—horizontal members of the fence.

3.1.2.1 *Discussion*—

May be top, bottom, intermediate or brace rails.

3.1.3 The dimensional terminology is shown in Fig. 1.

3.1.4 The relationship of measured dimension (used throughout) to trade and industry usage is shown in Table 1.

3.1.5 *open sections*—non-tubular framework sections (such as H-posts, C-posts, and roll-formed top rail).

3.1.6 *polymer coatings*—examples of some polymer coatings are acrylic urethane, polyurethane, polyvinyl chloride (PVC), polyester, and polyolefin elastomer.

3.1.7 See Terminology F552 for definitions of other terms.

4. Ordering Information

4.1 Orders for steel fence framework purchased to this specification shall include the following information:

4.1.1 Number of posts and rails by size and length,

4.1.2 Type of outside and inside coating (Section 7) and class of material,

4.1.3 Color, if applicable, in accordance with Specification F934,

4.1.4 Material group (IA, IC, IC-L, II, II-L, III, III-L, IV, IV-L) (Tables 2-4 Table 2),

4.1.5 Certification, if required, and

4.1.6 Exception(s) to this specification, or special requirements, if any.

NOTE 1—These details may be covered in whole or in any part by accompanying the orders with design drawings and notations thereon.

5. Strength Requirements

5.1 It is the intent of this specification to permit the continuance of historically ~~proved~~ proven practice in the installation of chain link fence systems, and to provide strength requirements for alternative shapes and materials. Two categories are described. Heavy industrial/Industrial fence represents the most rigid and mechanically durable of the commonly installed framework. Light industrial/commercial/Industrial/Commercial fence, as provided herein, exhibits 80 % of the load bearing capability of heavy industrial fence. The summary requirements and options for heavy industrial fence are given in Heavy Industrial fence Table 3 and those of Light Industrial/Commercial Fence are given in Table 4. Table 3.

5.2 *Historical Practice*—Experience has shown that galvanized steel performs satisfactorily as fence posts and rails if furnished to the standard weight (Schedule 40, Regular Grade, 30,000 psi) and nominal sizes listed in Specification F1083. Therefore, the minimum performance criteria is based on the historical strength of Specification F1083 Schedule 40, Regular Grade, 30,000 psi minimum yield.

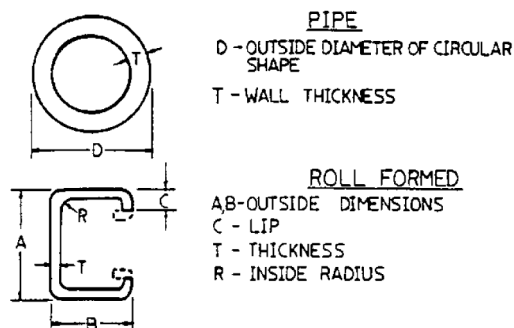

FIG. 1 Definitions of Dimensional Terms

TABLE 1 Pipe Diameter Terminology

Trade Size, in. (mm)	Actual Outside Diameter	
	in.	mm
1 $\frac{3}{8}$ (33.40)	1.315	33.40
1 $\frac{1}{2}$ (42.16)	1.660	42.16
1 $\frac{7}{8}$ (48.26)	1.900	48.26
2 $\frac{3}{8}$ (60.33)	2.375	60.33
2 $\frac{1}{2}$ (73.03)	2.875	73.03
3 $\frac{1}{2}$ (88.90)	3.500	88.90
4 (101.60)	4.000	101.60
4 $\frac{1}{2}$ (114.30)	4.500	114.30
5 $\frac{1}{16}$ (141.30)	5.563	141.3
6 $\frac{5}{8}$ (168.28)	6.625	168.28
8 $\frac{5}{8}$ (219.08)	8.625	219.08

TABLE 2 Definitions of Fence Framework Materials Design

Material	Description of Material
Group IA Round Steel Pipe	Steel pipe shall be produced to conform to Specification F1083 , standard weight (Schedule 40). Weight shall not vary more than 10 % \pm from that prescribed.
Group IC/IC-L Round Steel Pipe (Electric Resistance Welded Pipe)	Steel pipe shall be produced in accordance with commercial standards. Minimum yield strength shall be 50 000 psi (344 MPa). Such products shall include, without seeking to limit to, cold-formed and welded pipe. Weight shall not vary more than 10 % \pm from that prescribed.
Group II/II-L Roll-Formed Steel Shapes (C-Sections)	Roll formed steel shapes shall be produced to commercial standards. Minimum yield strength shall be 50 000 psi (344 MPa), and 60 000 psi (413 MPa) for the 3.25 in. \times 2.50 in. line post sections. The formed lip shall be of the same thickness as the flat elements and shall project no less than $\frac{1}{8}$ the width of the flat element being stiffened. Group II products shall be designated such that the strong axis is perpendicular to the line of fence. Weight shall not vary more than 10 % \pm from that prescribed.
Group III/III-L Hot-Rolled Shapes (H Beams)	Hot-rolled shapes shall meet the specified criteria and exhibit a minimum yield strength of 50 000 psi (344 MPa). Weight shall not vary more than 10 % \pm from that prescribed.
Group IV/IV-L Alternate Design	Any suitable design can be delivered, provided it meets the strength and stiffness criteria of Table 3 (Heavy Industrial) or Table 4 (Light Industrial/Commercial) and the producer has supplied, in a form acceptable to the purchaser, data that demonstrates conformance with the specification. At the producer's option the methods in either Section 6 or 6.4 may be used.
Group IV/IV-L Alternate Design	Any suitable design can be delivered, provided it meets the strength and stiffness criteria of (Heavy Industrial) or (Light Industrial/Commercial) and the producer has supplied, in a form acceptable to the purchaser, data that demonstrates conformance with the specification. At the producer's option the methods in either Section 6 or 6.4 may be used.

TABLE 3 Summary of Requirements for Heavy Industrial and Light Industrial/Commercial Fence Framework
TABLE 3 Group IA—Summary of Requirements for Hot Dipped, Welded Schedule 40 Regular Grade, Intermediate Strength Grade and High Strength 83000 Grade Heavy Industrial Steel Pipe—Hot Dipped

Reference Specifications	Steel F1083		Regular Grade	Intermediate Strength Grade	High Strength 83000 Grade
	Uses	Wall Thickness	Weight	Minimum Yield	Minimum Yield
Framework Size O.D.					
1.660 in. (42 mm)	Rail and Braces	0.140 in. (3.6 mm)	2.27 lb/ft (3.4 kg/m)	30000 psi (205 Mpa)	83000 psi (572 Mpa)
1.900 in. (48 mm)	Line Post	0.145 in. (3.7 mm)	2.72 lb/ft (4 kg/m)	30000 psi (205 Mpa)	83000 psi (572 Mpa)

2.375 in. (60 mm)	Line Post and Terminal	0.154 in. (3.9 mm)	3.65 lb/ft (5.4kg/m)	30000 psi (205 Mpa)		83000 psi (572 Mpa)
2.875 in. (73 mm)	Line Post and Terminal	0.203 in. (5.2 mm)	5.80 lb/ft (8.6 kg/m)	30000 psi (205 Mpa)		83000 psi (572 Mpa)
3.500 in. (89.9 mm)	Line Post and Terminal	0.216 in. (5.49 mm)	7.58 lb/ft (11.3 kg/m)	30000 psi (205 Mpa)		83000 psi (572 Mpa)
4.000 in. (102 mm)	Line Post and Terminal	0.226 in. (5.7 mm)	9.12 lb/ft (13.6 kg/m)	30000 psi (205 Mpa)		83000 psi (572 Mpa)
4.500 in. (114.3 mm)	Line Post and Terminal	0.237 in. (6.02 mm)	10.8 lb/ft (16.1 kg/m)	30000 psi (205 Mpa)		83000 psi (572 Mpa)
5.563 in. (141.3 mm)	Line Post and Terminal	0.258 in. (6.55 mm)	14.63 lb/ft (21.77 kg/m)	30000 psi (205 Mpa)	50000 psi (344 Mpa)	83000 psi (572 Mpa)
6.625 in. (168 mm)	Line Post and Terminal	0.280 in. (7.11 mm)	18.99 lb/ft (28.3 kg/m)	30000 psi (205 Mpa)	50000 psi (344 Mpa)	83000 psi (572 Mpa)
8.625 in. (219.10 mm)	Terminal	0.322 in. (8.18 mm)	28.58 lb/ft (42.5 kg/m)	30000 psi (205 Mpa)	50000 psi (344 Mpa)	83000 psi (572 Mpa)

Note: Group IA material is available in three yield strengths:

IA-1. Regular Grade—Minimum yield strength shall be 30 000 psi (205 Mpa)

IA-2. Intermediate Strength Grade—Minimum yield strength shall be 50 000 psi (344 MPa) available in 5.563 in. (141.3 mm) OD and larger.

IA-3. High Strength 83 000 Grade—Minimum yield strength shall be 83 000 psi (572 Mpa)

Group IA Hot-Dipped Protective Zinc Coating:

1.1 Zinc for coating shall be Special High Grade per ASTM B6.

1.2 O.D. 1.8 oz/ft² (550 g/m²) minimum average in accordance with Specifications F1083.

1.3 I.D. 1.8 oz/ft² (550 g/m²) minimum average in accordance with Specifications F1083.

1.4 If so specified O.D. 2.0 oz/ft² 610 g/m²) minimum average.

1.5 If so specified I.D. 2.0 oz/ft² 610 g/m²) minimum average.

TABLE 3 Group IC Summary of Requirements Galvanized High Strength Material Heavy Industrial Steel Pipe—Galvanized

Reference Specifications	Steel--Galvanized Before Forming A653/A653M and A924/924M Steel--Galvanized After Forming A1011/1011M	Uses	Wall Thickness	Weight	Minimum Yield (psi)
Framework Size O.D.					
1.660 in. (42 mm)		Rails and Braces	0.111 in. (2.8 mm)	1.84 lb/ft (2.74 kg/m)	50 000 psi (344 MPa)
1.900 in. (48 mm)		Line Post	0.120 in. (3 mm)	2.28 lb/ft (3.39 kg/m)	50 000 psi (344 MPa)
2.375 in. (60 mm)		Line Post and Terminal	0.130 in. (3.3 mm)	3.12 lb/ft (4.64 kg/m)	50000 psi (344 MPa)
2.875 in. (73 mm)		Line Post and Terminal	0.160 in. (4 mm)	4.64 lb/ft (6.90 kg/m)	50 000 psi (344 MPa)
3.500 in. (89.9 mm)		Line Post and Terminal	0.160 in. (4.06 mm)	5.71 lb/ft (8.50 kg/m)	50 000 psi (344 MPa)
4.000 in. (102 mm)		Line Post and Terminal	0.160 in. (4.1 mm)	6.56 lb/ft (9.76 kg/m)	50 000 psi (344 MPa)
4.500 in. (114.3 mm)		Line Post and Terminal	0.160 in. (4.1 mm)	7.42 lb/ft (11.04 kg/m)	50 000 psi (344 MPa)

TABLE 3 Group IC-L Summary of Requirements for Galvanized High Strength Material Light Industrial Steel Pipe—Galvanized

Reference Specifications	Steel--Galvanized Before Forming A653/A653M and A924/924M Steel--Galvanized After Forming A1011/1011M	Uses	Wall Thickness	Weight	Minimum Yield (psi)
Framework Size Inches					
0.1660 in. (42 mm)		Rails and Braces	0.085 in. (2.16 mm)	1.43 lb/ft (2.12 kg/m)	50000 psi (344 MPa)
0.1900 in. (48 mm)		Line Post	0.090 in. (2.3 mm)	1.74 lb/ft (2.59 kg/m)	50000 psi (344 MPa)
2.375 in. (60 mm)		Line Post and Terminal	0.095 in. (2.4 mm)	2.31 lb/ft (3.44 kg/m)	50000 psi (344 MPa)
2.875 in. (73 mm)		Line Post and Terminal	0.110 in. (2.8 mm)	3.25 lb/ft (4.84 kg/m)	50000 psi (344 MPa)
4.000 in. (102 mm)		Line Post and Terminal	0.160 in. (4.1 mm)	6.56 lb/ft (9.76 kg/m)	50000 psi (344 MPa)

Note: Table 3 Group IC/IC-L products are available in two types of coatings.

1. Group IC Galvanized Before Forming

1.1 Zinc for exterior coating shall be Special High Grade per ASTM B6.

1.2 O.D. zinc weight to be a minimum of 0.9 oz/ft² (275 g/m²) with a verifiable verifiable polymer overcoat.

1.3 I.D. zinc weight to be a minimum of 0.9 oz/ft² (275 g/m²).

1.4 Framework produced from galvanized steel sheet meeting Specification A653/A653M shall have exterior welded surface recoated with the same type of material and thickness of base coating.

2. Group IC-L Galvanized Before Forming

2.1 Zinc for exterior coating shall be Special High Grade per ASTM B6.

2.2 O.D. zinc weight to be a minimum of 0.9 oz/ft² (275 g/m²) with a verifiable polymer overcoat.

2.3 I.D. zinc weight to be a minimum of 0.9 oz/ft² (275 g/m²).

2.4 Framework produced from galvanized steel sheet shall have the exterior welded surface recoated with the same type of material and thickness of base coating.

3. Group IC Galvanized After Forming

3.1 Zinc for exterior coating shall be Special High Grade per ASTM B6.

3.2 O.D. zinc weight to be a minimum of .9 oz/ft² (275 g/m²) with a verifiable polymer overcoat.

3.3 I.D. coating to be 81% nominal zinc pigmented coating, 0.3 mils (0.0076 mm) minimum coverage.

4. Group IC-L Galvanized After Forming

4.1 Zinc for exterior coating shall be Special High Grade per ASTM B6.

4.2 O.D. zinc weight to be a minimum of 0.9 oz/ft² (275 g/m²) with a verifiable polymer overcoat.

4.3 I.D. coating to be 81% nominal zinc pigmented coating, 0.3 mils (0.0076 mm) minimum coverage.

TABLE 3 Summary of Requirements for Heavy Industrial Fence Framework

Description	Pipe	Roll-Formed	Hot-Formed	III	Performan
	IA	IG	II		
Material	Steel	Steel	Steel	Steel	
Reference Specification	F1083 Regular Grade 30 000-psi Intermediate Strength-Grade 50 000-psi Available in 5.563-in. O.D. and larger High-Strength Grade 83 000-psi				The S... Product... Steel... 5- Strength... 6- Strength... and-if requ... producers... provide inf... which Grou... this is an A... The Altern... meet or ex... requiremen... referenced
Minimum Yield Strength, psi (MPa)	30 000 (205) 50 000 (344)	50 000 (344) 60 000 (414)	50 000 (344)	50 000 (344)	
	For Sizes 5.563 in. O.D. and Larger and 83 000 (572)				
Framework	See Fig. 1 for Definitions of Dimensional Terms				
Rail or Braces	D = 1.660 in. (42 mm) T = 0.140 in. (3.6 mm) 2.27 lb/ft (3.38 kg/m)	D = 1.660 in. (42 mm) T = 0.111 in. (2.8 mm) 1.84 lb/ft (2.74 kg/m)	A = 1.625 in. (41.2 mm) B = 1.25 in. (31.7 mm) C = 0.375 in. (9.5 mm) R = 0.1875 in. (4.76 mm) T = 0.80 in. (2.0 mm) 1.35 lb/ft (2.01 kg/m)		
Line Post	D = 1.900 in. (48 mm) T = 0.145 in. (3.7 mm) 2.72 lb/ft (4.05 kg/m)	D = 1.900 in. (48 mm) T = 0.120 in. (3.0 mm) 2.28 lb/ft (3.39 kg/m)	A = 1.875 in. (47.6 mm) B = 1.625 in. (41.2 mm) C = 0.5625 in. (14.3 mm) R = 0.25 in. (6.4 mm) T = 0.121 in. (3.1 mm) 2.40 lb/ft (3.39 kg/m)		
Line or Terminal Post	D = 2.375 in. (60 mm) T = 0.154 in. (3.9 mm) 3.65 lb/ft (5.43 kg/m)	D = 2.375 in. (60 mm) T = 0.130 in. (3.3 mm) 3.12 lb/ft (4.64 kg/m)	A = 2.25 in. (57.2 mm) B = 1.70 in. (43.2 mm) C = 0.75 in. (19.1 mm) R = 0.25 in. (6.4 mm) T = 0.121 in. (3.1 mm) 2.78 lb/ft (4.13 kg/m) (Line Post Only)	A = 2.25 in. (57.2 mm) B = 1.70 in. (43.2 mm) R = 0.25 in. (6.4 mm) a = 10 T = 0.125 in. (3.2 mm) 3.26 lb/ft (4.85 kg/m) (Line Posts Only)	
Line or Terminal Post	D = 2.875 in. (73 mm) T = 0.203 in. (5.2 mm) 5.79 lb/ft (8.62 kg/m)	D = 2.875 in. (73 mm) T = 0.160 in. (4 mm) 4.64 lb/ft (6.90 kg/m)	A = 3.25 in. (82.6 mm) B = 2.50 in. (64.0 mm) C = 1.00 in. (25.4 mm) R = 0.25 in. (6.4 mm) T = 0.130 in. (3.30 mm) 4.50 lb/ft (6.70 kg/m) (60 000 min yield) (Line Post Only)		
Line or Terminal Post	D = 3.5 in. (89.9 mm) T = 0.216 in. (5.49 mm) 7.58 lb/ft (11.3 kg/m)	D = 3.5 in. (89.9 mm) T = 0.160 in. (4.06 mm) 5.71 lb/ft (8.50 kg/m)			
Line or Terminal Post	D = 4.000 in. (102 mm) T = 0.226 in. (5.7 mm) 9.11 lb/ft (13.56 kg/m)	D = 4.000 in. (102 mm) T = 0.160 in. (4.1 mm) 6.56 lb/ft (9.76 kg/m)			

TABLE — Continued

Description	Pipe	Roll-Formed	Hot-Formed	III	Performance
Material	IA	IG	II	Steel	
	Steel	Steel	Steel		
Line or Terminal Post	D = 4.50 in. (114.3 mm) T = 0.237 in. (6.02 mm) 10.80 lb/ft (16.1 kg/m)	D = 4.50 in. (114.3 mm) T = 0.160 in. (4.14 mm) 7.42 lb/ft (11.04 kg/m)			
Line or Terminal Post	D = 5.563 in. (141.3 mm) T = 0.258 in. (6.55 mm) 14.63 lb/ft (21.77 kg/m)				
Line or Terminal Post	D = 6.625 in. (168 mm) T = 0.280 in. (7.11 mm) 18.97 lb/ft (28.3 kg/m)				
Terminal Post	D = 8.625 in. (219.10 mm) T = 0.322 in. (8.18 mm) 28.58 lb/ft (42.50 kg/m)				

See Figure 1 for Definition of Dimensional Terms: A, B, C, R, T

D = outside diameter
R = radius at surface (max)
a = flange taper (degree of angle)
T = thickness (wall)

TABLE 3 Group II Summary of Requirements for Hot Dipped Roll-Formed Material Heavy Industrial Roll-Formed, Galvanized

Reference Specifications	Steel—A1011/A1011M Grade 50 Others	Uses	T	Weight	Minimum Yield (psi)
A=1.625 in. (41.2 mm)		Rail and Braces	0.080 in. (2.0 mm)	1.35 lb/ft (2.01 kg/m)	50 000 psi (344 MPa)
B=1.25 in. (31.7 mm)					
C=0.375 in. (9.5 mm)					
R=.01875 in. (4.76 mm)					
A=1.875 in. (47.6 mm)		Line Post	0.121 in. (3 mm)	2.40 lb/ft (3.39 kg/m)	50 000 psi (344 MPa)
B=1.625 in. (41.2 mm)					
C=0.5625 in. (14.3 mm)					
R=.25 in. (6.4 mm)					
A=2.25 in. (57.2 mm)		Line Post	0.121 in. (3 mm)	2.78 lb/ft (4.13 kg/m)	50 000 psi (344 MPa)
B=1.70 in. (43.2 mm)					
C=0.75 in. (19.1 mm)					
R=.25 in. (6.4 mm)					
A=3.25 in. (82.6 mm)		Line Post	0.130 in. (3.3 mm)	4.50 lb/ft (6.70 kg/m)	60 000 psi (413 MPa)
B=2.50 in. (64.0 mm)					
C=1.00 in. (25.4 mm)					
R=.025 in. (6.4 mm)					

See Figure 1. for Definition of Dimensional Terms: A, B, C, R, T