



Designation: **C1277—11** **C1277 – 12**

Standard Specification for Shielded Couplings Joining Hubless Cast Iron Soil Pipe and Fittings¹

This standard is issued under the fixed designation C1277; the number immediately following the designation indicates the year of original adoption or, in the case of revision, the year of last revision. A number in parentheses indicates the year of last reapproval. A superscript epsilon (ϵ) indicates an editorial change since the last revision or reapproval.

1. Scope

1.1 This specification covers the materials and testing of shielded hubless couplings to join hubless cast iron soil pipe and fittings.

1.2 Several different types of hubless couplings are available for use in hubless cast iron sanitary and storm drain, waste and vent piping applications to connect hubless cast iron soil pipe and fittings by using a sleeve-type, or some other type coupling device. It is the purpose of this specification to furnish information as to the characteristics of one such sleeve type couplings when applied to cast iron soil pipe and fittings manufactured in accordance with Specification **A888**, latest revision, and CISPI-301, latest revision.

1.3 The values stated in inch-pound units are to be regarded as standard. The values given in parentheses are mathematical conversions to SI units that are provided for information only and are not considered standard.

1.4 The committee with jurisdiction over this standard is aware of other comparable standard published by the Cast Iron Soil Pipe Institute, CISPI-310, FM 1680 published by Factory Mutual, and Specification **C1540** published by ASTM.

1.5 The following precautionary caveat pertains only to the test method portion, Section 7, of this specification. *This standard does not purport to address all of the safety concerns, if any, associated with its use. It is the responsibility of the user of this standard to establish appropriate safety and health practices and determine the applicability of regulatory limitations prior to use.*

2. Referenced Documents

2.1 ASTM Standards:²

A240/A240M Specification for Chromium and Chromium-Nickel Stainless Steel Plate, Sheet, and Strip for Pressure Vessels and for General Applications

A644 Terminology Relating to Iron Castings

A888 Specification for Hubless Cast Iron Soil Pipe and Fittings for Sanitary and Storm Drain, Waste, and Vent Piping Applications

C564 Specification for Rubber Gaskets for Cast Iron Soil Pipe and Fittings

C1540 Specification for Heavy Duty Shielded Couplings Joining Hubless Cast Iron Soil Pipe and Fittings

D3677 Test Methods for Rubber—Identification by Infrared Spectrophotometry

2.2 CISPI Standard:

CISPI-301 Specification for Hubless Cast Iron Soil Pipe and Fittings for Sanitary and Storm Drain, Waste and Vent Piping Applications³

CISPI-310 Specification for Couplings for Use in Connection with Hubless Cast Iron Soil Pipe and Fittings for Sanitary and Storm Drain, Waste, and Vent Piping Applications³

2.3 Factory Mutual Standard:

FM 1680 Couplings Used in Hubless Cast Iron Systems for Drain, Waste or Vent, Sewer, Rainwater or Storm Water System, Above or Below Ground, Industrial, Commercial and Residential⁴

¹ This specification is under the jurisdiction of ASTM Committee **A04** on Iron Castings and is the direct responsibility of Subcommittee **A04.75** on Gaskets and Coupling for Plumbing and Sewer Piping.

Current edition approved July 1, 2011; Dec. 1, 2012. Published August 2011; January 2013. Originally approved in 1994. Last previous edition approved in 2009 as **C1277 – 09a**; **C1277 – 11**. DOI: 10.1520/C1277-11; 10.1520/C1277-12.

² For referenced ASTM standards, visit the ASTM website, www.astm.org, or contact ASTM Customer Service at service@astm.org. For *Annual Book of ASTM Standards* volume information, refer to the standard's Document Summary page on the ASTM website.

³ Available from Cast Iron Soil Pipe Institute (CISPI), 5959 Shallowford Rd., Suite 419, Chattanooga, TN 37421, http://www.cispi.org.

⁴ Available from Factory Mutual Research, 1151 Boston-Providence Turnpike, Norwood, MA, 02062.

3. Terminology

3.1 Definitions of the following terms used in this specification are found in Terminology [A644](#), elastomeric and durometer.

3.2 *Definitions of Terms Specific to This Standard:*

3.2.1 *center stop, n*—an integral part of the gasket centered on the axial length of the gasket intended to limit the insertion depth of the pipe to be coupled.

3.2.2 *clamp assembly, n*—that portion of the coupling excluding the gasket and shield.

3.2.3 *corrugated, n*—any method of embossing.

3.2.4 *coupling, n*—the complete assembly.

3.2.5 *fitting, n*—parts of a pipeline other than straight pipes, valves, or couplings.

3.2.6 *gasket, n*—the elastomeric portion of the coupling.

3.2.7 *joint, n*—the point of assembly consisting of the coupling and the joined pipes or fittings, or both.

3.2.8 *manufacturer clamp assembly and shield, n*—The entity that attaches the clamp assembly to the shield for the couplings covered by this standard specification.

3.2.9 *manufacturer gaskets, n*—The entity that molds the gaskets covered by this standard specification.

3.2.10 *shield, n*—an external metallic protective device designed to protect the sealing gasket from external elements that could cause failure of the sealing gasket.

4. Materials and Manufacture

4.1 Physical properties of gaskets shall comply with Specification [C564](#) and the dimensions, material specifications, physical and chemical properties as shown in [Fig. 1](#), [Fig. 2](#), [Table 1](#), and [Table 2](#).

4.2 Clamp assembly screws or bolts shall not have screwdriver slots.

5. Elastomeric Gasket Requirements

5.1 The gaskets shall be tested in accordance with Test Methods [D3677](#) and be manufactured from a properly vulcanized virgin compound where the primary elastomer is polychloroprene (neoprene).

5.2 The elastomeric gasket shall consist of one piece conforming to the physical requirements of Specification [C564](#). The gaskets shall be tested by the gasket manufacturer for compliance to Specification [C564](#) during each day of production not to exceed 24 h for each size of gasket being produced. These tests shall be performed at the manufacturer location during the time of production. These tests shall include hardness, elongation and tensile strength, tear strength and compression set. Heat aging, water absorption, ozone resistance, and oil immersion tests shall be performed annually or when the formulation changes or sources of supply, whichever occurs first.

5.2.1 The elastomeric gasket shall have an inside center stop that does not create an enlargement chamber or recess with a ledge, shoulder, or reduction of pipe area or offer an obstruction to flow.

5.2.2 The elastomeric gasket shall be free of defects that affect the use and serviceability.

6. Clamp Assembly Requirements

6.1 The shield and clamp assembly shall be made of material conforming to the requirements as outlined in Section [6](#), [Table 3](#) and [Fig. 3](#).

6.1.1 All parts shall be of 300 series stainless steel. All parts made from round stock shall be of 300 series stainless steel (excluding copper bearing alloys). The shield shall be corrugated or otherwise provided with a mechanism to accommodate maximum and minimum OD's of pipe and fittings and include 2 stainless steel bands for sizes 1½ to 4 in. and 4 bands for 5 to 10 in. and 6 bands for 12 and 15 in. Each tightening device housing shall interlock with a band at the unslotted end. The bands are to be fastened to the shield by riveting or such other method that will insure that the bands will not become separated from the shield. The shield and clamp assembly shall comply with dimensions and material specifications, as are given in [Table 3](#), [Fig. 3](#), and [Fig. 4](#).

6.1.2 Clamp assemblies shall be tested to withstand no less than 125 % of manufacturers stated installation torque or a minimum of 60 lbf-in. (6.78 N-m) of applied torque, whichever is greater, without visible signs of failure. The clamp assembly shall be tested over a steel mandrel of the appropriate diameter and torqued as required. These tests shall be performed randomly on selected samples during the course of production as needed but not less than one clamp per shift per size during band production.

6.1.3 The clamped shield shall meet the requirements of [Table 3](#).

6.1.4 The couplings shall meet the dimensional requirements of [Fig. 3](#).

7. Couplings Requirements and Test Methods

7.1 Assemble each coupling tested according to the manufacturer's instructions between two sections of randomly selected hubless cast iron soil pipe meeting the requirements of CISPI-301 or Specification [A888](#) and conduct the following test: deflection

TABLE 1. RUBBER SLEEVE

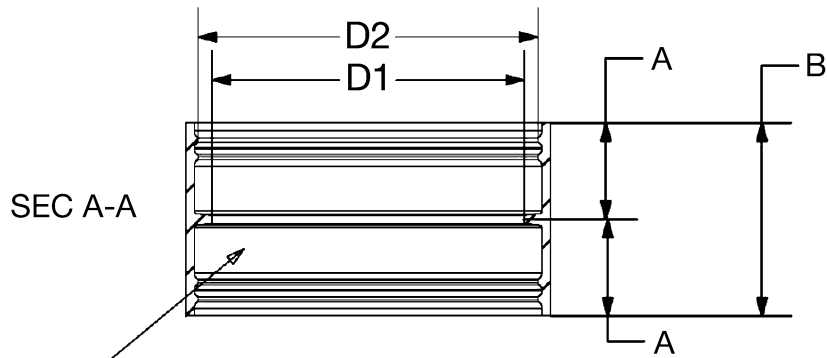

MARKINGS SHALL BE BETWEEN SEALING BEADS AND CENTER STOP.
MARKINGS MAY BE ON BOTH SIDES OF CENTER STOP

ITeH Standards
(<https://standards.iteh.ai>)
Document Preview

ASTM C1277-12
<https://standards.iteh.ai/catalog/standards/sist/857ae86f-10c6-4451-881f-7f6cfbe6c092/astm-c1277-12>

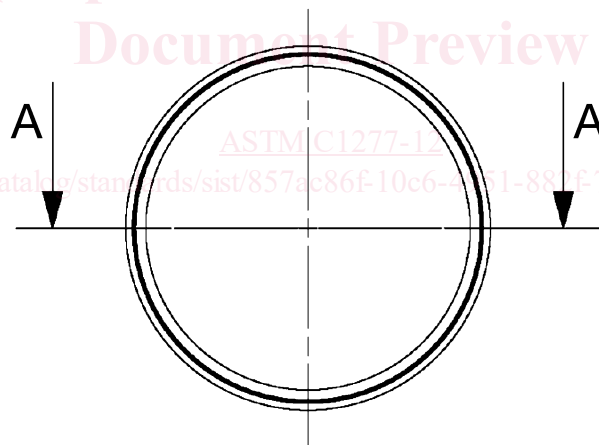

FIG. 1 Rubber Gasket

and shear. In addition, an unrestrained hydrostatic test will be performed between two sections of machined steel pipe. The unrestrained hydrostatic tests shall be performed on randomly selected couplings of each size during the course of production using first article selection not to exceed 30 days. The deflection and shear tests shall be performed on randomly selected couplings of each size during production whenever a change of design occurs or not to exceed 120 days, whichever is the shorter period.

7.1.1 Deflection Test:

7.1.1.1 A test apparatus such as the one shown in Fig. 5 is suggested. Other testing apparatus that provide restraint to the assembly shall also be permitted. Close the outboard ends of the pipe with test plugs.

7.1.1.2 Fill the assembly with water, expel all air, and hydrostatically pressurize to 4.3 psi (29.6 kPa) for the duration of the test. One pipe shall be rigidly supported and while the assembly is under pressure, raise the opposite end of the other pipe 1/2 in. (12.7 mm) per lineal foot of pipe. Maintain the pressure for 5 min. Any leakage shall mean failure.

7.1.2 Shear Test:

7.1.2.1 Support two joined lengths of randomly selected hubless cast iron soil pipe on blocks, a minimum of 1 1/2 in. (38.1 mm) high, at three locations. One length shall be a minimum of 24 in. (609.6 mm) in length, supported on blocks, one near the

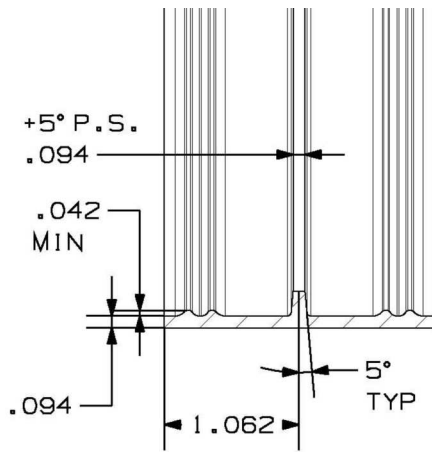

DIMENSIONS FOR 1.5"-4" SIZES

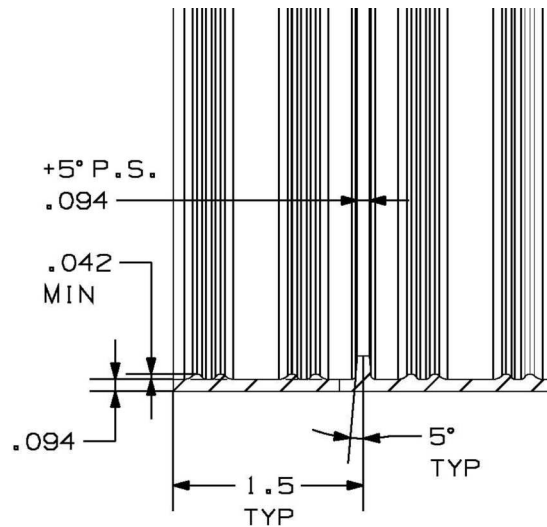

DIMENSIONS FOR 5"-6" SIZES

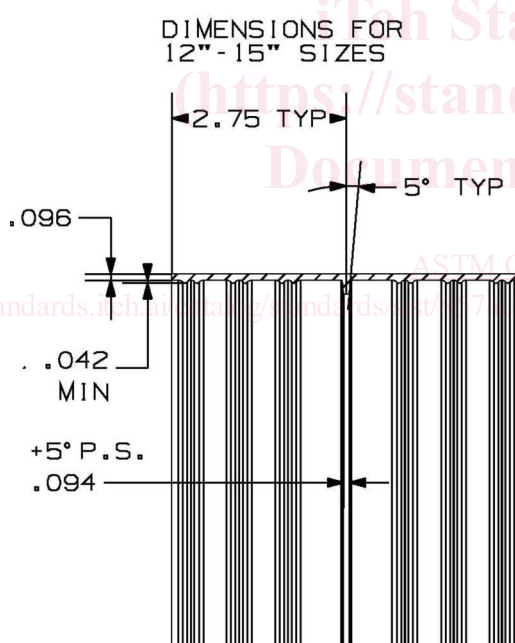

DIMENSIONS FOR 12"-15" SIZES

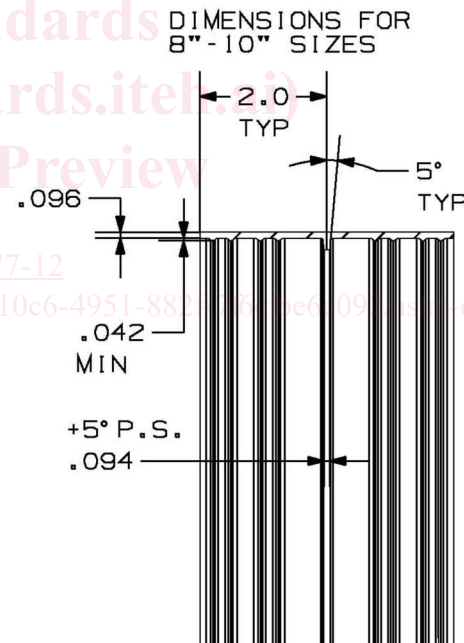

DIMENSIONS FOR 8"-10" SIZES

NOTE 1—Dimensions found in these drawings are for informational purposes only. The dimensions A and B found in the table are mandatory. Dimensions D1 and D2 found in the table are reference for mold design. Tolerances are found in Fig. 2. The center stop width is (3/32) .094 plus the 5° draft angle. Sealing ring shape and dimensions are to manufacturer's design.

	1½ in.	2 in.	3 in.	4 in.	Dimensions					
					5 in.	6 in.	8 in.	10 in.	12 in.	15 in.
A	1.062	1.062	1.062	1.062	1.500	1.500	2.000	2.000	2.750	2.750
B	2.125	2.125	2.125	2.125	3.000	3.000	4.000	4.000	5.500	5.500
D1	1.531	1.968	2.968	4.000	4.968	5.968	7.968	9.975	12.000	15.200
D2	1.937	2.343	3.343	4.406	5.343	6.343	8.343	10.350	12.430	15.650

NOTE 2—Dimensional Tolerances to be RMA Class 3 (See Table 1).

FIG. 1 Rubber Gasket (continued)

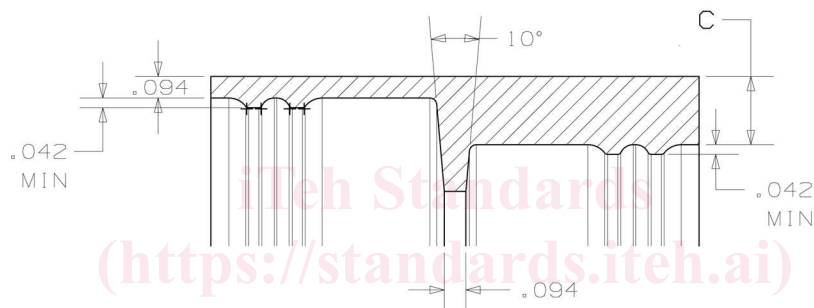
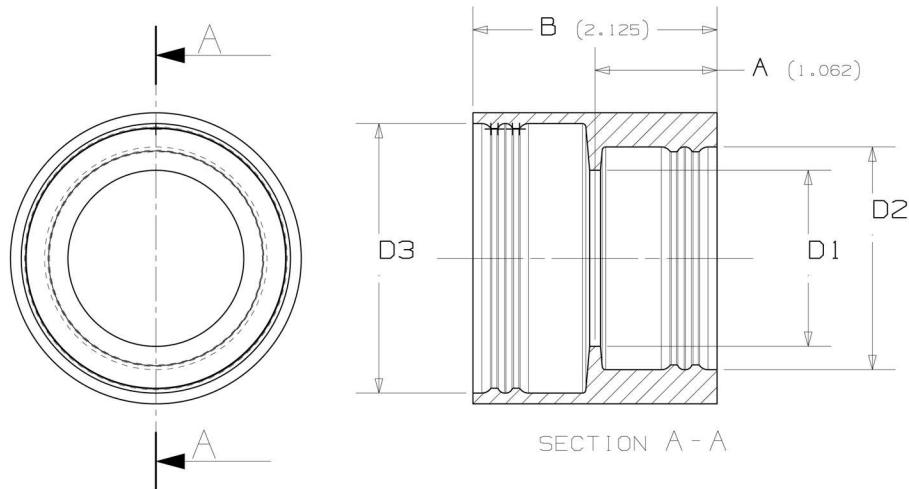

	2 X 1.5	3 X 2	4 X 3
A	1.062	1.062	1.062
B	2.125	2.125	2.125
C	0.297	0.594	0.625
D1	1.531	1.968	2.968
D2	1.937	2.343	3.343
D3	2.343	3.343	4.406

REDUCING SLEEVES

NOTE 1—Dimensions found in these drawings are for informational purposes only. The dimensions found in the table are mandatory. Tolerances are found in Fig. 2. Sealing ring shape and dimensions are to manufacturer's design.

	Dimensions for Reducing Sleeves		
	2 x 1-1/2	3 x 2	4 x 3
A	1.062	1.062	1.062
B	2.125	2.125	2.125
C	0.297	0.594	0.625
D1	1.531	1.968	2.968
D2	1.937	2.343	3.343
D3	2.343	3.343	4.406

NOTE 2—Dimensional Tolerances to be RMA Class 3 (See Table 1).

FIG. 2 Reducing Rubber Gasket

uncoupled end, and the other immediately adjacent to the couplings. Firmly restrain this length in position as shown in Fig. 6. The other coupled length shall be a minimum of 5 ft (1.52 m) in length and supported by a single block 6 in. (152.4 mm) from the end of the pipe.

7.1.2.2 Fill the assembly with water and expel all air. Apply a load of 50 lb/in. of nominal diameter at a point 6 in. (152.4 mm) from the edge of the coupling upon a 12 in. (304.8 mm) length of (3 by 3) angle iron or load distribution pad located on the top of the pipe immediately adjacent to the coupling of the pipe having one support only. Under this loading there shall be no visible leakage or displacement of more than 3/8 in. (9.53 mm) from true alignment adjacent to the coupling, when an internal pressure equivalent to a 10 ft (3.05 m) head of water 4.3 psi (29.6 kPa) is applied. Maintain the load and internal pressure for 15 min.

**TABLE 1 Dimensional Tolerances for Rubber—Standard
Dimensional Tolerances RMA CLASS 3**

Size, in.	Fixed, ±	Closure, ±
0 to 0.499	0.010	0.015
0.500 to 0.999	0.010	0.018
1.000 to 1.999	0.015	0.020
2.000 to 2.999	0.020	0.025
3.000 to 3.999	0.025	0.030
4.000 to 4.999	0.030	0.035
5.000 to 7.999	0.035	0.050

7.1.3 Unrestrained Hydrostatic Test:

7.1.3.1 Assemble each coupling tested according to the manufacturer’s instruction between two sections of machined steel pipe and conduct the thrust test.

7.1.3.2 The assembly shall consist of a maximum outside diameter pipe connected to a minimum outside diameter pipe with diameters as referenced in **Table 4** and lengths as shown in **Fig. 7**. Machine the plain ends of the pipe to be used for the thrust test to the correct diameters. Plain ends shall have 0.015 in. (0.38 mm) deep grooves machined circumferentially around them at 1/8 in. (3.18 mm) intervals down the pipe section for a distance equal to that covered by the elastomeric sleeve of the coupling being tested. The tool used to machine the grooves shall have a 60° inclined angle and cut into the pipe from a perpendicular position. The surface between the grooves shall be a lathe turned surface of 125 RMS.

7.1.3.3 The plain ends of the pipe for the thrust test shall be uncoated and cleaned with acetone and thoroughly dried before each assembly.

7.1.4 Test Method:

7.1.4.1 Support the pipe assemblies in a manner that does not restrain joint movement as shown in **Fig. 7**.

7.1.4.2 Fill the pipe assembly (as required in **7.1.3**) with water, expelling all air. Increase the hydrostatic pressure at a rate of 1 psi (6.9 kPa) every 30 s until the specified test pressure is reached. The specified test pressure shall be 20 psi (137.9 kPa) for 1½ in. (38.1 mm) through 5 in. (127 mm), 18 psi (124.1 kPa) for 6 in. (152.4 mm), 10 psi (68.9 kPa) for 8 in. (203.2 mm), and 6 psi (41.4 kPa) for 10 in. (254 mm) pipe, 12 in. (305 mm), and 15 in. (380 mm). When the specified test pressure is reached, hold it for 5 min. Any leakage or axial joint movement of more than 0.150 in. (3.81 mm) shall mean failure.

8. Markings and Identification

8.1 *Marking*—The gasket shall be marked with raised letters. This marking shall consist of pipe size, country of origin, manufacturer’s identifying mark, and Specification **C564**. Such marking shall not exceed 0.02 in. in relief.

8.2 The shield and clamp assembly shall be marked with indented letters. All marking shall be placed on the band assemblies. Marking on the band shall consist of pipe size. Marking on the screw housing shall consist of coupling manufacturer’s name or registered trademark with a national registry of trademarks in the country in which the product is installed, the words ALL STAINLESS, country of origin.

9. Certification

9.1 Upon request, the purchaser, design professional, or the administrative authority having jurisdiction where the products are being installed shall be furnished certification, by the manufacturer, stating samples representing each lot have been tested and inspected as indicated in this specification and the requirements have been met. If requested by the purchaser, design professional, or the administrative authority having jurisdiction where the products are being installed, certification shall be accompanied by test reports as prepared in accordance with Sections **4-8** of this specification. Certification shall include the legal name and address of each manufacturer. Third Party certifiers or inspectors shall utilize the procedures detailed in **Annex A1** when conducting inspections at the manufacturing locations.

10. Keywords

10.1 cast iron soil pipe; hubless couplings; no hub couplings; no hub pipe